

Selected problems of biocompatibility of the pneumatically controlled arm

Wiktor Parandyk, Bartłomiej Zagrodny, Jan Awrejcewicz

Department of Automation and Biomechanics, Lodz University of Technology

Abstract: A prototype of arm, aimed to simulate human arm is presented. In the device following original constructions have been proposed: glenohumeral joint, elbow joint, and wrist joint with the possibility of ulna and radius rotation. Also special shape of radial bone and ulna bone has been proposed. In addition, pneumatic McKibben-type muscles and their control have been examined. The comparison of the range of motions of the prototype and a biological system in the meaning of the SFTR method is also presented.

Keywords: artificial arm, pneumatics, McKibben

1. Introduction

The number of humanoid designs increases significantly, however, such robots are still far from being fully functional. Many times it can be observed that nature is so perfect that bionic solutions turned out to be the most effective. Such biosimilar structures often find application for example as industrial robots (see for example [1]). The first similar to human arms were prostheses, usually powered by electrical motor or combined drive (e.g. electro-pneumatic) (see for example [2–4]). Usually, prototypes presented by other authors have only functional similarity (for example [5, 6]). No designs with structural similarity were found.

The prototype of artificial pneumatic arm, modeled on the human arm is presented in this paper. The prototype is driven with McKibben type muscles because of its simplicity of construction and similarity to the biological muscles (see for example [1, 7, 8]). During the construction of the device several problems have been encountered, for example: the bone shapes and its durability have to be taken into account in the construction of the prototype, muscles force characteristics and its functional displacements, also, joints and their range of motion cause additional restrictions. The main purpose of the artificial arm construction is to simulate full functionality of biological movements. The shape and the complex mobility (activity) of human arm also cause many technical problems, which have to be considered.

2. Arm Design

In the prototype, shapes of human bones were taken under consideration (see fig. 1). Because of complicated biological joint shapes, similar but simplified constructions were proposed for glenohumeral joint (fig. 2), elbow (fig. 3), and wrist (fig. 4).



Fig. 1. Photography of prototype bone system: 1 – articulatio humeri, 2 – humerus, 3 – hinge elbow joint (humeroulnar and humeroradial), 4 – proximal radioulnar joint, 5 – radius, 6 – ulna, 7 – distal radioulnar joint

Rys. 1. Fotografia systemu kostnego prototypu: 1 – staw ramienny, 2 – kość ramienna, 3 – zawiasowy staw łokciowy (ramiennie-łokciowy, ramiennie-promieniowy), 4 – staw promieniowo-łokciowy bliższy, 5 – kość promieniowa, 6 – kość łokciowa, 7 – staw promieniowo-łokciowy dalszy

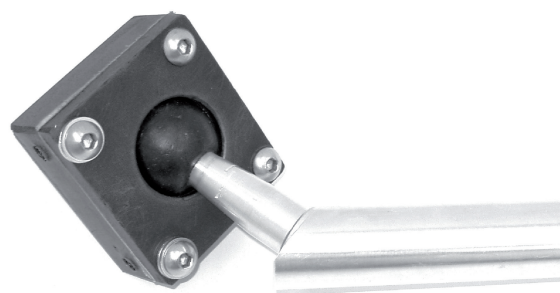

Fig. 2. Articulatio humeri of the artificial arm
Rys. 2. Staw ramienny sztucznego ramienia

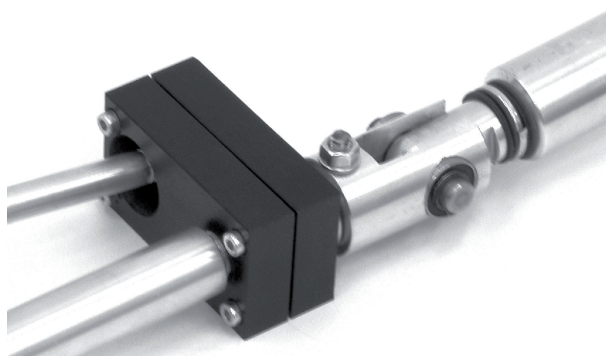

Fig. 3. Elbow joint of the artificial arm
Rys. 3. Staw łokciowy sztucznego ramienia

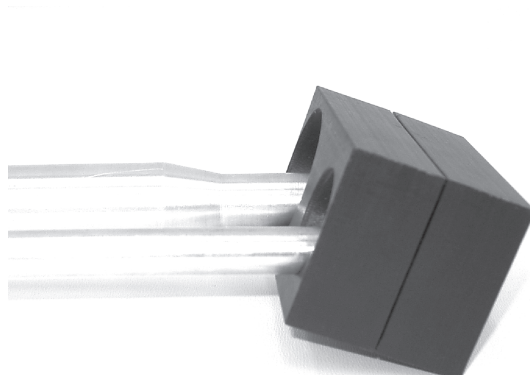

Fig. 4. Distal radioulnar joint of the artificial arm
Rys. 4. Staw promieniowo-łokciowy dalszy sztucznego ramienia

Tab. 1. Range of motions comparison for arm joints according to SFTR method. Norm: International Standard Orthopedic Measurements [9, 10]

Tab. 1. Porównanie zakresów ruchów w nawiązaniu do metody pomiaru SFTR. Międzynarodowa Norma Pomiarów Ortopedycznych [9, 10]

Range of motion Joint/ body part	Plane	Norm	Only skeletal system	Prototype with McKibben-type muscles
Articulatio humeri	S	50-0-110	No limits	35-0-80
	F	90-0-30	80-0-10	80-0-10
	T	30-0-135	60-0-60	60-0-60
	R(F90)	90-0-80	No limits	80-0-80
	R(F0)	60-0-70	45-0-45	40-0-40
Elbow	S	0-0-150	0-0-140	0-0-140
Forearm	R	90-0-80	175-0-175	80-0-60
Radiocarpal joint	S	50-0-60	25-0-25	25-0-25
	F	20-0-30	0-0-0	0-0-0

Tab. 2. Biological muscles taken into consideration for the needs of the project

Tab. 2. Mięśnie biologiczne użyte dla potrzeb projektu

No.	Muscles groups	Considered muscles	Function
1	Anterior muscles of the shoulder girdle	Subscapularis	Arm internal rotation
2	Lateral muscles of the shoulder girdle	Deltoid muscle (deltoideus)	Arm flexion and extension, horizontal arm abduction
3	Posterior muscles of the shoulder girdle	Teres major	Arm extension
4	Anterior muscles of the arm	Biceps (biceps brachii)	Arm flexion, forearm flexion, forearm supination
5		Brachial muscle (brachialis)	Forearm flexion
6	Posterior muscles of the arm	Triceps (triceps brachii)	Arm and forearm extension, Arm adduction
7	The surface layer of the anterior group of forearm muscles	Pronator teres	Forearm pronation
8	Deep layer of posterior muscle groups of the forearm	Supinator	Forearm supination

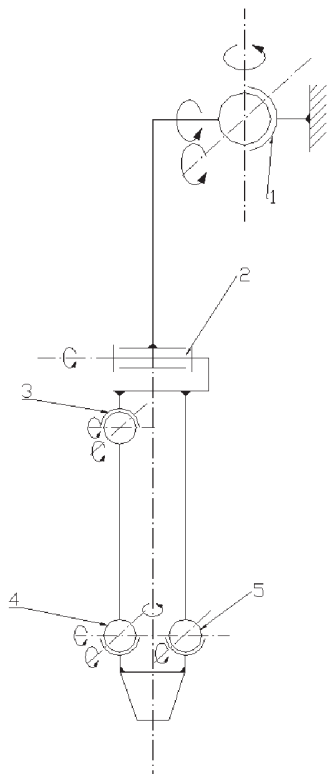

Fig. 5. Structural scheme of the mechanism: 1, 3, 4, 5 – ball-type connections, 2 – hinge connection

Rys. 5. Schemat strukturalny mechanizmu: 1, 3, 4, 5 – połączenia kuliste, 2 – połączenie zawiasowe (obrotowe)

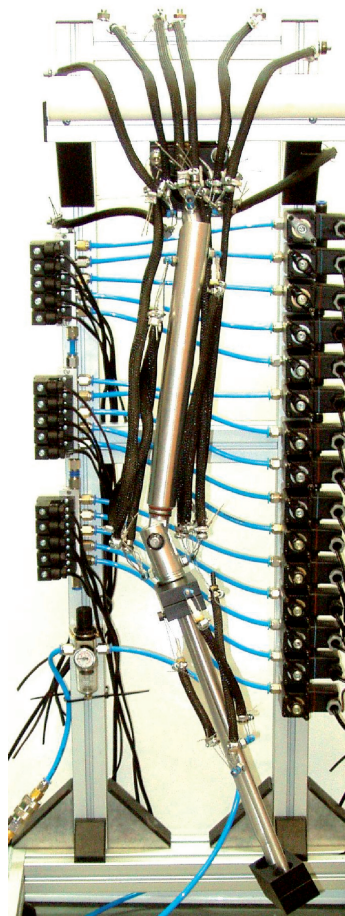

Fig. 6. Muscle system of the prototype
Rys. 6. System mięśniowy prototypu



Fig. 7. Muscle system of the arm
Rys. 7. System mięśniowy ramienia

These joints were suggested as a ball-socket type. Humeroulnar and humeroradial joints were proposed as one hinge joint. This construction has almost the same movement range as a biological construction (tab. 1). Fig. 5 presents a structural scheme of the prototype.

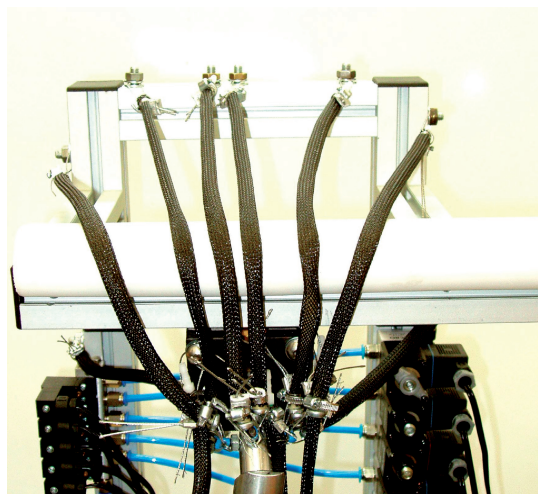

Fig. 8. Muscle system of the shoulder
Rys. 8. System mięśniowy stawu ramiennego (barku)

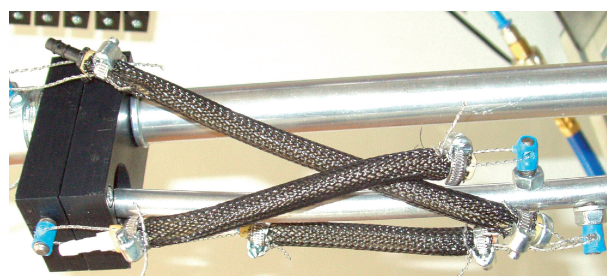

Fig. 9. Muscle system of the forearm
Rys. 9. System mięśniowy przedramienia

Pneumatic McKibben-type muscles were used as actuators. Because of their lower functional displacement (about 25 %, biological muscles up to 50 % [9]), it was essential to use longer pneumatic muscles than their biological analogue to complete full range of motion. Muscle system is presented in figures 6–9.

3. Control system

The pneumatic artificial muscles control system (fig. 10) is fundamentally based on two groups of elements: (i) air prepare and flow direction control pneumatic components,

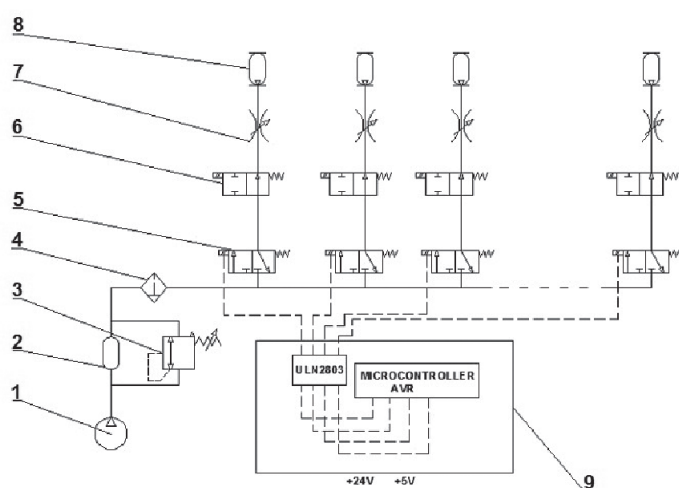

Fig. 10. Control system scheme: 1 – air compressor, 2 – compressed air tank, 3 – pressure valve, 4 – air filter, 5 – reversing 3/2 valves, 6 – cut-off 2/2 valves, 7 – throttle valves, 8 – McKibben-type muscles, 9 – electronics

Rys. 10. Schemat układu sterowania: 1 – sprężarka tłokowa, 2 – zbiornik sprężonego powietrza, 3 – redukcyjny zawór ciśnieniowy, 4 – filtr powietrza 5 – elektrozawory rozdzielające 3/2, 6 – elektrozawory odcinające 2/2, 7 – zawory dławiące, 8 – mięśnie pneumatyczne typu McKibbena, 9 – moduł elektroniczny

(ii) electronics based on integrated circuit elements and microcontrollers.

Solenoid reversing valves are responsible for particular motions of the kinematic chain of the arm which in fact makes it possible to put compressed air into particular actuator by the programmed sequence. The second control step is made of solenoid cut-off valves which are able to keep the arm in any position, cutting off the outflow from the muscle. The speed ratio of the following motion is controlled by manual throttle valves. To sum up, the artificial arm movements are realized by two levels of pneumatic solenoid valves.

The main elements of presented control system are two programmable microcontrollers put on printed-circuit board which gives a possibility to power particular valve coil by generating output signals onto amplifier inputs in programmed sequence.

It is clear that the movement control is in fact put on the air flow direction control system to power properly spaced pneumatic muscles.

4. Conclusions

Because of high degree of complexity of the biological musculo-skeletal system some simplifications were made. Also some lack of biocompatibility of McKibben-type actuators in comparison to the biological muscles causes many limitations. However, as presented in tab. 1, limits in range of motion are not significant. There are some improvements needed, to make it possible to obtain results almost the same as biological system. At this stage palm was neglected – this is the reason why in

radiocarpal joint in F plane we have no possibility of movement – this part of the joint, responsible for palm bending was also neglected.

Acknowledgements

This paper is supported by "Master Programme" of the Foundation for Polish Science.

Bibliography

1. Tondu B., Ippolito S., Guiochet J., Daidie A., *A Seven-degrees-of-freedom, Robot-arm Driven by Pneumatic Artificial Muscles for Humanoid Robots*, "The International Journal of Robotics Research", 2005, Vol. 24, No. 4, 275–274.
2. Jacobsen S.C., Knutti D.F., Johnson R.T., Sears H.H., *Development of the Utah Artificial Arm*, "IEEE Transaction On Biomedical Engineering", 1982, Vol. BME-29, 249–269.
3. McKenzie D.S., *The Clinical Application of Externally Powered Artificial Arms*, "The Journal of Bone and Joint Surgery", 1965, Vol. 47B No. 3, 399–410.
4. Marquard E., *The Heidelberg Pneumatic Arm Prosthesis*, 1965, Vol. 47B, No. 3, 425–434.
5. Nakamura N., Sekiguchi M., Kawashima K., Fujita T., Kagawa T., *Development of Robot Using Pneumatic Artificial Rubber Muscles to Operate Construction Machinery*, "Journal of Robotics and Mechatronics", 2004, Vol. 16, No. 1, 8–16.
6. Norihiko S., Saikawa T., Okano H., *Flexor Mechanism of Robot Arm Using Pneumatic Muscle Actuators*, Proceedings of the IEEE, 2005, 1261–1266.
7. Dindorf R., *Model i charakterystyki mięśniów pneumatycznych*, „Pomiary Automatyka Robotyka”, nr 2/2004, 22–25.
8. Ping Ch., Hannaford B., *Measurement and Modeling of McKibben Pneumatic Artificial Muscles*, "IEEE Transaction on Robotics and Automation", 1996, Vol. 12, No. 1, 90–102.
9. Bochenek A., *Anatomia Człowieka, Układ Ruchu*, PZW, Warszawa 2010.
10. Szczechowicz J., *Pomiary kątowe zakresu ruchu, zapisy pomiarów, metoda SFTR*, Podręczniki i Skrypty nr 23, AWF, Kraków 2004. ■

Wybrane problemy biogodności konstrukcji ramienia sterowanego pneumatycznie

Streszczenie: W artykule autorzy starali się pokazać problemy i ich rozwiązania, napotkane podczas konstrukcji modelu ludzkiego ramienia sterowanego pneumatycznie. W założeniu konstrukcyjnym prototyp miał posiadać pełną funkcjonalność konstrukcji biologicznej. Podczas realizacji przedsięwzięcia natrafiono na liczne problemy jak: odwzorowania kości, mięśni, stawów, ich skomplikowanych kształtów i działania. Zaproponowano następujące rozwiązania praktyczne: staw ramienno-łokciowy bliższy i dalszy wraz z możliwością obtaczania się specjalnie ukształtowanej kości promie-

niowej po kości łokciowej. Ponadto dobrano odpowiedni typ mięśni pneumatycznych wraz z ich sterowaniem zapewniając odpowiedni zakres ruchów i funkcjonalności układu. W pracy pokazano ponadto porównanie zakresu ruchów wspomnianej konstrukcji i układu biologicznego w rozumieniu metody SFTR oraz porównanie pewnych, wybranych parametrów mięśni biologicznych i pneumatycznych typu McKibben.

Słowa kluczowe: sztuczne ramię, pneumatyka, mięśnie McKibben'a

Wiktor Parandyk, MSc

He was born in 1988. He received the MSc degree in mechatronics from Lodz University of Technology, Lodz in 2012. Now he is a PhD mechanics student at the Department of Automation and Biomechanics, Lodz University of Technology. His current research interests include biomechanic and physiological analogs modelling.

e-mail: parandyk.wiktor@gmail.com



Bartłomiej Zagrodny, PhD

In 2008, he was graduated in Applied Mathematics at the Faculty of Technical Physics, Information Technology and Applied Mathematics. In 2012 he received PhD in Mechanics at the Faculty of Mechanical Engineering, Lodz University of Technology. Author and co-author of a few publications in the field of biomechanics and thermal imaging.

e-mail: b.zagrodny.pl@gmail.com



Prof. Jan Awrejcewicz, DSc, PhD

He was born in Telesze, Poland on August 26, 1952. He received the MSc and PhD degrees in the field of Mechanics from the Lodz University of Technology in 1977 and 1981, respectively. He received also his bachelor's degree in Philosophy in 1978 from the University of Lodz, and DSc. degree in Mechanics from Lodz University of Technology in 1990. He is an author or co-author of 538 publications in scientific journals and conference proceedings, monographs (37), text books (2), edited volumes (4), conference proceedings (11), journal special issues (12), and other books (8) and other short communications and unpublished reports (238). He is now the Head of Department of Automatics and Biomechanics, and the Head of PhD School on 'Mechanics' associated with the Faculty of Mechanical Engineering of the Lodz University of Technology. In 1994 he earned the title of Professor from the President of Poland, Lech Wałęsa, and in 1996 he obtained the golden cross of merit from the next President of Poland, Aleksander Kwaśniewski. He is a contributor to 50 different research journals and to 300 conferences. During his scientific travel he visited 60 different countries. His papers and research cover various disciplines of mathematics, mechanics, biomechanics, automatics, physics and computer oriented sciences.

e-mail: awrejcew@p.lodz.pl

