

cascade pressure exchange, gas-turbine engines, working cycle,
temperature, power efficiency, performance,
wave-rotor topping cycle, self-cooling

Aleksander KRAJNIUK

East-Ukrainian National University named after V. Dal
Molodyozhny block, 20a, Lugansk, 91034, Ukraine
**Corresponding author. E-mail: ljangar@rambler.ru*

**THE NEW DEVICES OF GAS-TURBINE ENGINES OF GROUND
TRANSPORT ON THE BASIS CASCADE PRESSURE EXCHANGER OF
KRAJNIUK**

Summary. Main trends of perfection of gas-turbine engines (GTE) of transport plants by application of principles of the cascade pressure exchange (CPE) for air compression in the working cycle of gas-turbine plant have been analyzed. The principle of action and performances of work of heat compressor CPE realizing compression of working body on the whole at the expense straight convert inputting heat in disposing work of torrent with insignificant distraction mechanics work from shaft selection of power has been described. The results of computational investigation of four variants of the GTE working process organization on the basis of the two-staged compression assembly with intermediate cooling and heating of air-gas medium have been adduced. Application of units CPE in the capacity of compressing stage GTE opens the prospect of adaptations GTE performance by conditions of work in the capacity of forcing units of overland transport.

**НОВЫЕ УСТРОЙСТВА ГАЗОТУРБИНЫХ ДВИГАТЕЛЕЙ НАЗЕМНОГО
ТРАНСПОРТА НА БАЗЕ КАСКАДНОГО ОБМЕННИКА ДАВЛЕНИЯ
КРАЙНЮКА**

Аннотация. Рассмотрены основные направления совершенствования газотурбинных двигателей (ГТД) транспортных установок применением принципов каскадного обмена давлением (КОД) для сжатия воздуха в рабочем цикле установки. Раскрыт принцип действия и показатели работы теплового компрессора КОД, осуществляющего сжатие рабочего тела в основном за счёт прямого преобразования подводимой теплоты в располагаемую работу потока с незначительным отвлечением механической работы от вала отбора мощности. Приведены результаты расчетного исследования четырех вариантов организации рабочего процесса ГТД на базе двухступенчатого агрегата сжатия с промежуточным охлаждением и подогревом газоздушных сред. Применение агрегатов КОД в качестве компрессорной ступени ГТД раскрывает перспективу адаптации показателей ГТД к условиям работы в качестве силовых установок наземного транспорта.

INTRODUCTION

Compactness, high aggregate power and dynamic balance of modern gas-turbine engines (GTE) causes their attractiveness to use as the primary power-generating units of mobile systems. The basic obstruction of GTE wide integration in ground transport is high sensitivity to change of almost all operating conditions of the plant that is peculiar to blade machines. It is resulted in a decline of traction and economic characteristics even at an insignificant deviation of regimes of its work from the nominal. Acceleration characteristics and fuel economy at idle stroke are especially unsatisfactory for variable service conditions of the GTE. The turbine-driven units have the restricted resource and demand high level of maintenance in view of a high rotational speed of the rotor. Insignificant unbalance of rotors, for example, caused by pollution or blade breakage, generates an extreme reinforcement of vibrating and dynamic loads.

Despite high thermal efficiency of theoretical cycle, in practice the possibility to raise power efficiency of the GTE (by increase in the maximum temperature of the cycle) is restricted by thermo-strength properties of materials applied in turbine construction. One of known directions of possible increase in the relation of boundary temperatures of a cycle at restriction of temperature of gases in front of the turbine is connected with the use of wave rotors as topping stage for gas turbine [1 - 6].

The idea of using wave-rotor topping cycle has been first proposed by Claude Seippel of Brown Boveri Company (BBC) in Switzerland in 1942 [7, 8]. Now BBC is Asea Brown Boveri (ABB) and its pressure wave supercharger termed as the Compres has been used commercially for passenger car and heavy diesel engines [9, 10].

Interest in wave-rotor technology has again increased recently [5, 6, 11 - 13], the detailed thermodynamic analysis of several possibilities to top a gas turbine with wave rotor is resulted in the work [5].

The general advantage of using a wave rotor consists in possible increase in thermodynamic efficiency of the cycle by raise of its maximum temperature at restriction of temperature of gases in front of the turbine.

According to the circuit design on fig. 1, the air compressed in the compressor arrives in a wave exchanger (enters the wave rotor) and is further compressed inside the wave rotor channels. After the additional compression of the air in the wave rotor, it discharges into the combustion chamber. The hot gas leaving the combustion chamber enters the wave rotor and compresses the air received from the compressor. To provide the energy transfer to compress the air, the burnt gas partially expands in the wave rotor en reroute to the turbine. In this configuration, combustion takes place at a higher pressure and temperature than in a conventional gas turbine engine with the same compressor exit state, while being limited to the same turbine inlet temperature.

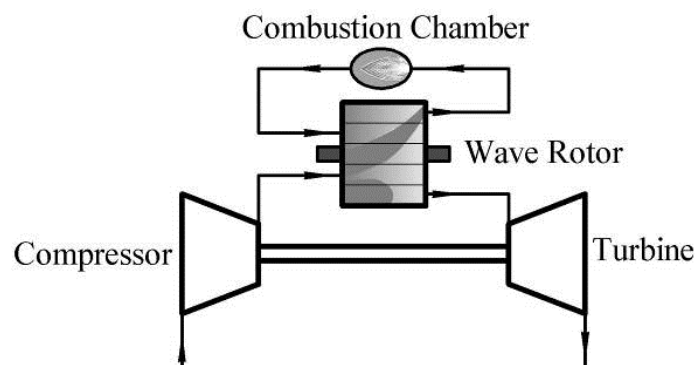

Fig. 1. GTE with a wave exchanger of pressure

Рис. 1. Газотурбинный двигатель с волновым обменником давления

Practical possibility of an increase of temperature of gases in a line of high pressure of the GTE is caused by self-cooling feature of throat-flow wave rotors to support average temperature of walls due

to periodic cooling of cells by air, keeping wall at relatively uniform intermediate temperature. According to [6] the turbine inlet total pressure is typically 15% to 20% higher than pressure of the air delivered by the compressor. This pressure gain is in contrast to the untopped engine where the turbine inlet pressure is always lower than the compressor discharge pressure, due to the pressure loss across the combustion chamber. As a result of the wave rotor pressure gain, more work can be extracted from the turbine, increasing overall engine thermal efficiency and specific work.

At the same time, use of wave rotor in the capacity of top stage of the gas-turbine engine does not eliminate, and in some cases aggravates the main deficiency of the gas-turbine engine – unsatisfactory efficiency on transitive and partial regimes. Strongly expressed wave character of exchange processes in wave rotor predetermines the sensitivity of its consumed characteristics to thermodynamic parameters of working mediums in gas-distributing windows and to rotor rotational speed. The deviation of operating mode of the GTE from design conditions is accompanied by a sharp decline of parameters of wave rotor work as owing to both an error signal of the moments of connection of cells to gas-distributing windows, and owing to increase in incompleteness of displacement of compressed air in the combustion chamber. On the regimes considerably removed from nominal, destruction of the adjusted picture of interaction of primary waves with inlet edges of windows of tap of working mediums leads to disappearance of a scavenging pulse in lines of low and high intermediate pressure and, hence, - to pressure decrease of gases in front of the turbine concerning pressure of air which is discharged under pressure by the compressor. It is necessary to notice also that the inevitable dissipation of energy in the course of formation and interaction of strong shock waves restricts efficiency of the best specimens of wave rotors on design conditions by values of 0,59 ... 0,61 [14].

Considerable jump in performance and operating characteristics of transport gas turbine engine can be achieved by applying the principles of the cascade exchange of pressure for realization of compression of gas-air working mediums in the running cycle of the plant. The units realizing such compression are the cascade pressures exchangers (CPE). They represent new generation of exchangers of pressure with mainly static character of interacting of the compressing and compressed mediums [15, 16].

1. PROPERTIES OF THE CASCADE PRESSURE EXCHANGER

The working cycle of the CPE on the basis of recuperative use of potential energy of a residual pressure for realization of the basic compression of air in the course of the cascade power interchange is characterized by high efficiency and also by insensibility to deviation of operating conditions from design conditions. Remarkable feature of the CPE working cycle consists in insignificant effect of incompleteness of displacement of compressed air from rotor cells (effect of so-called «dead volume») on efficiency of the exchanger. The reason of such insensibility is quite explainable. Really, the energy of the compressed air which has remained in the cell after disconnection with the window of air of a high pressure participates in process of the cascade mass transfer and, hence, along with energy of compressing gas in the cell is directly consumed for the subsequent compression of a fresh charge.

In view of the fact that only insignificant part of compressing gas is consumed on «re-compression» of air preliminary compressed in the process of the cascade mass transfer, *approximate* equality of volume charges of the compressing and compressed mediums takes place in the CPE. Thus, the ratio of mass flow rates at insignificant excess of pressure of compressing gas P_{g1} , concerning pressure of discharged under pressure air P_k is close to an inverse ratio of temperatures of those mediums.

Rather low rotational speed of a rotor (2000... 3000 mines-1) stipulates essentially large reliability and less rigid technological requirements to manufacturing of the cascade exchangers concerning turbo-compressors and wave rotor.

High efficiency and reliability of the CPE is confirmed by test of some pilot specimens at the stand of motor tests on the basis of the Diesel engine 6ЧН12/14 (see fig. 2) in laboratory of the department "Internal Combustion Engine" (ICE) of SNU named after V.Dahl. So, at parameters of compressing

gas $T_{g1}=850$ K, $P_{g1}=250$ MPa the attained efficiency of the exchanger with 10th mass transfer channels makes $\eta_{cpe}=0.84$. Reserve of the further raise of the exchanger efficiency is connected with increase of number of mass transfer channels and with decrease in leaks of working mediums in end face integrations of a rotor.

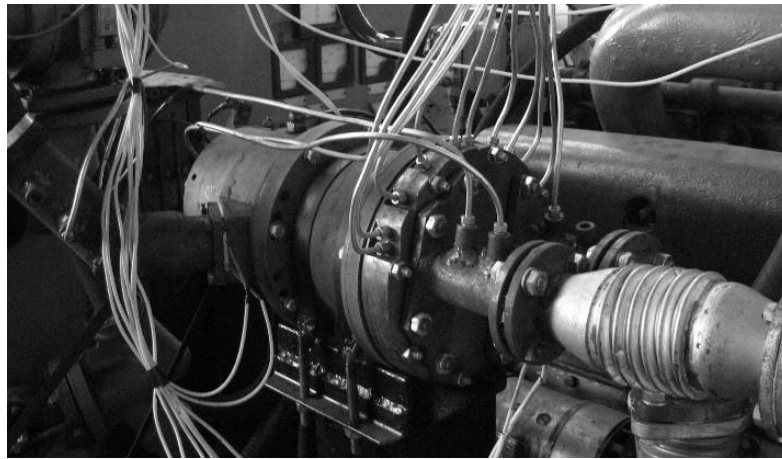

Fig. 2. Pilot specimen of the CPE

Рис. 2. Экспериментальный образец каскадного обменника давления

Power effectiveness of the CPE working cycle is realized in considerable excess of the consumption of compressed air concerning the compressing medium, in the greater degree, the higher temperature of the last (see fig. 3). Noted property of "charge multiplication» opens a prospect of creation of basic new installations of heat transforming multipurpose machines on the CPE baseline, such as: thermal compressors [17], gas-turbine engines, air refrigerating machines [18, 19], gas generators [20, 21], and supercharging systems of high forcing Internal Combustion Engines (ICE) also [22, 23].

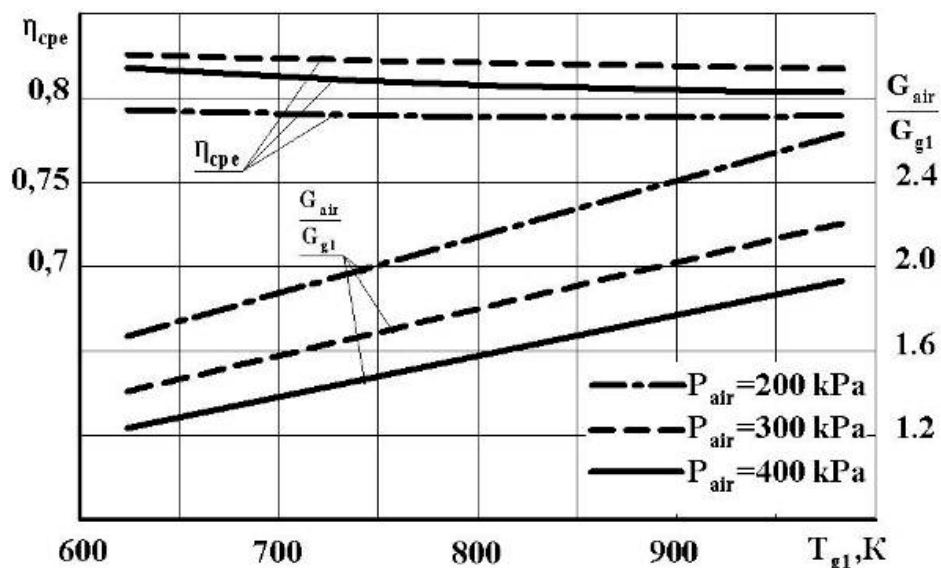

Fig. 3. Effect of temperature of the compressing medium T_{g1} on the efficiency η_{cpe} and the ratio of consumptions of the compressed and compressing medium G_{air}/G_{g1} in the CPE

Рис. 3. Влияние температуры среды T_{g1} на к.п.д. η_{cpe} и отношение полезного давления и давления среды в каскадном обменнике давления

2. USE OF PRINCIPLES OF THE CASCADE EXCHANGE BY PRESSURE IN SYSTEMS OF COMPRESSION OF AIR

In the elementary circuit design of the thermal compressor (fig. 4,a) on the basis of the cascade pressure exchanger 1, the input window of a high pressure 2 is connected with the outlet window of a high pressure 3 by means of the channel 4 with the source of heat supply 5 (internal combustion or an external heat supply) placed in the channel 4. The connecting pipe 6 of compressed air outlet to a user is connected to the channel 4 between the window 3 and heat supply 5. The part of air discharged under pressure by the exchanger 1 through a connecting pipe 6 is taken away to the user, another part through the channel 4 goes to the heat supply 5 where it is heated, and further is brought to the window 2 in the capacity of compressing medium.

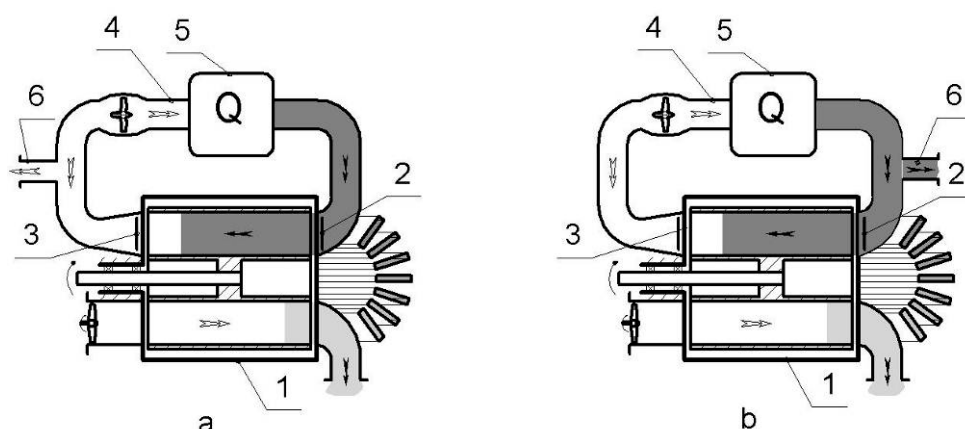

Fig. 4. Principal schemes of the thermal compressor (a) and the gas generator (b)

Рис. 4. Принципиальная схема термического компрессора (a) и газового генератора (b)

The overall performance of the thermal compressor is evaluated by power efficiency (η_k) according to expression:

$$\eta_k = (G \cdot H) / Q \quad (1)$$

where:

G – the compressed air charge; H – adiabatic heat drop; Q – the supplied heat.

From the point of view of transformation of the primary thermal energy, the experimentally confirmed values η_k of the thermal compressor efficiency are highly enough. On regimes of $T_z = 1000 \dots 1100$ K for $\pi_k = 3.9 \dots 4.2$ $\eta_k = 0.2 \dots 0.215$. The pressure head of the thermal compressor depends on the relative charge of compressed air \bar{G}_{out} . \bar{G}_{out} represents the ratio of the consumption of air which has been taken away to the user to mass carrying capacity of the rotor. The maximum degree of raise of pressure π_k and optimum value of \bar{G}_{out} by criterion of power inputs increases considerably with raise of the maximum temperature T_z of the cycle. Unique simplicity of the one-stage thermal compressor stipulates attractiveness of its application in systems of air supply with the maximum discharge pressure up to 0.4... 0.5. The design of the thermal compressor is easily converted to the gas generator by connection of the connecting pipe of the working medium outlet to the channel 4 between the heat supply 5 and the window 2 of the compressing medium input (see fig.4,b). The characteristics of productivity of the gas generator are analogous to parameters of the thermal compressor, but have higher values of power efficiency [9].

Higher pressure head and power efficiency is realized by the two-staged thermal compressor of the CPE with intermediate cooling of compressed air and heating of the compressing medium (fig. 5) [11].

Application of the CPE units in the capacity of compressor stage of the GTE allows to carry out working medium compression mainly at the expense of direct transformation of brought heat as a result of internal redistribution of an indicator work of the cascade power interchange with insignificant derivation of mechanical energy from the power take-off shaft. And due to it the power

turbine of the gas-turbine engine of the cascade pressure exchange (GTE - CPE) has several times smaller sizes concerning the turbine of the baseline GTE of equivalent power.

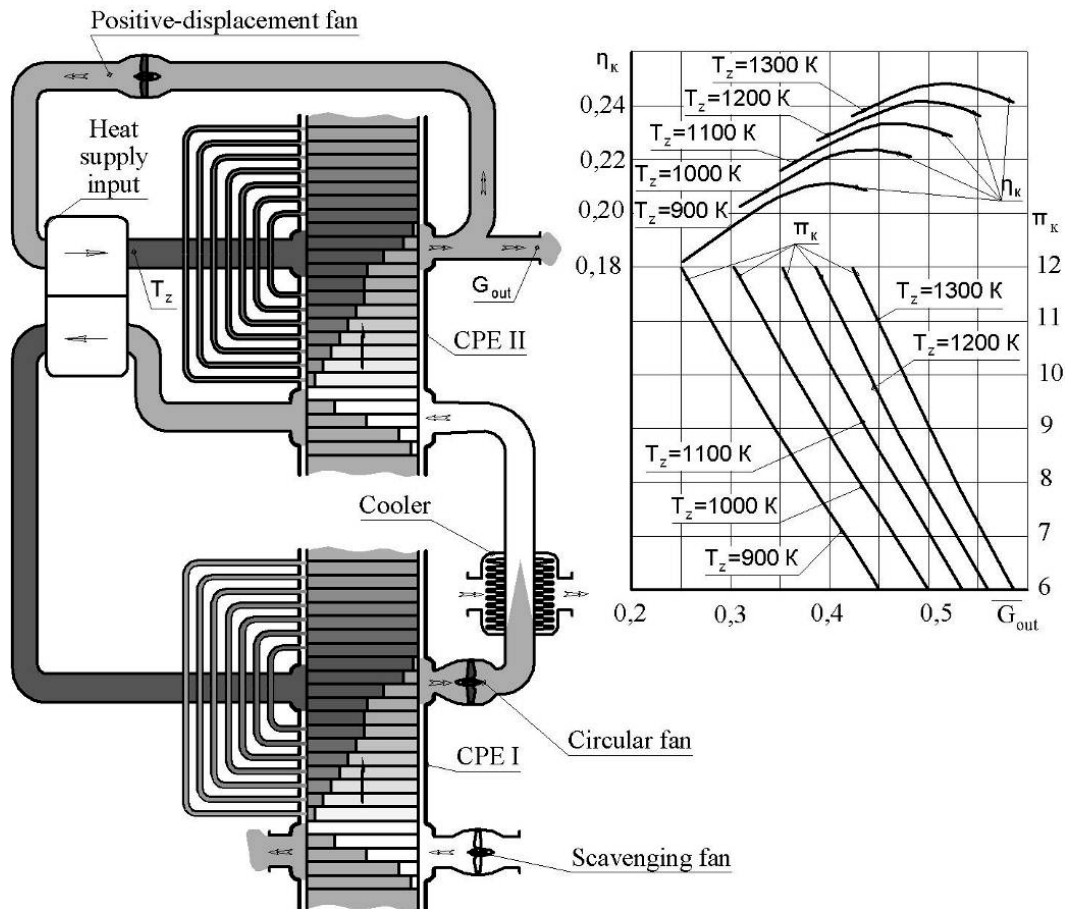

Fig. 5. The principal scheme and indexes of operation of two-staged thermal compressor the CPE
Рис. 5. Принципиальная схема и индексы эксплуатации двухступенчатого термического компрессора с каскадным обменником давления

3. PARAMETERS OF GAS-TURBINE ENGINES WITH THE COMPRESSOR STAGE OF THE CASCADE TYPE

There is a large variety of possible schemes of designs of GTE plants of the cascade pressure exchange. In this work four variants of the GTE working process organization on the basis of the two-staged compressor of the CPE with intermediate cooling of compressed air and reheating of expanding gases are analyzed. (Fig. 6, 7, 8, 9).

In the circuit design on fig. 6 (variant I) two stage cascade pressure unit with direct flow of working mediums is used in the capacity of the gas generators directly connected to the power turbine. The circuit design on fig. 7 (variant II) differs from the circuit design of variant I by the presence of a regenerator of the residual heat of the compressing gases leaving the first stage of cascade pressure unit. In the circuit design on fig. 8 (variant III) two stage cascade pressure unit is used in the capacity of a source of the compressed air which is discharged under pressure in the power turbine after heating in the regenerator by the residual heat of compressing gases. In the circuit design on fig. 9 (variant IV) the mixture of the air and gas flows which are discharged under pressure by two stage cascade pressure unit is used in the capacity of working medium of the power turbine.

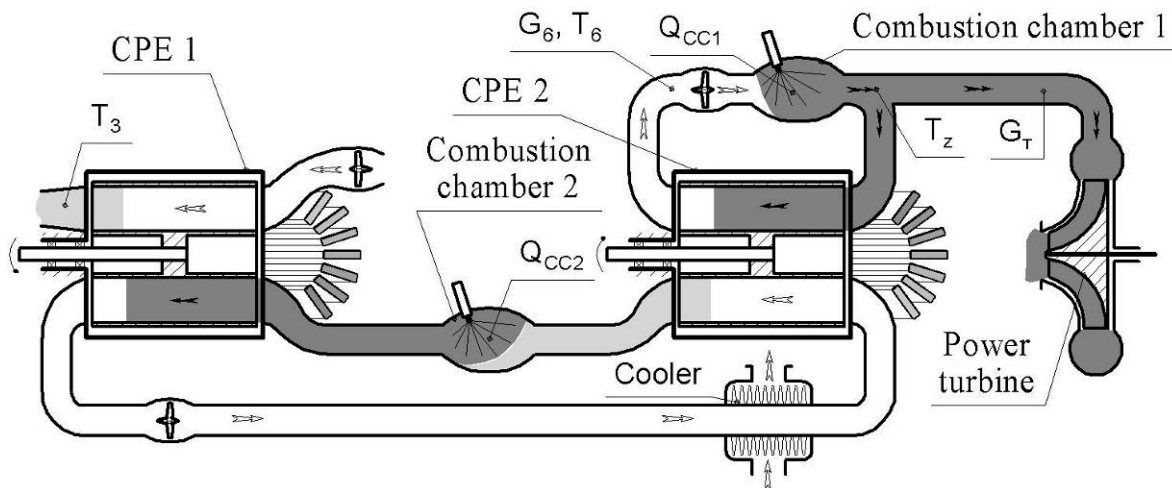

Fig. 6. Circuit design of the GTE with two stage cascade pressure unit

Рис. 6. Схема каскадного обменника давления с двухступенчатым каскадным блоком давления

The results of calculation determination of effective indexes of these variants of the GTE – CPE with various parameters of working process are completed in tab. 1, 2, 3, 4. According to circuit designs on fig. 6,7,8,9 the designations are specified: η_{GTE} , N_{GTE} - overall efficiency and power of engine correspondingly; $\pi_{k\Sigma}$, π_{k1} , π_{k2} - degrees of raise of pressure, the general in two-units of the CPE, in units of the CPE of 1st and 2nd stages correspondingly; Q_{CC1} , Q_{CC2} , Q_{reg} - power of thermal flows in the high pressure combustion chamber, in the intermediate pressure combustion chamber, in the regenerator of heat of the burnt (exhaust) gases correspondingly; G_6 and T_6 - accordingly the air charge (consumption) and air temperature through the window of high pressure of the CPE of 2nd stage; G_T - the consumption of gases through the power turbine; T_z - the maximum temperature of the cycle; T_T - working medium temperature in front of the power turbine; T_3 - temperature of compressing gases on the outlet from the second stage.

At calculation of performance of the GTE - CPE the turbine politropic efficiency is taken equal 0.81. 3% pressure drop is assumed in combustion chamber also (combustion pressure ratio $\pi_{comb}=0.97$). Geometrical sizes of the CPE units of both stages are invariable for various variants of circuit designs and conditions of the working processes organization of the GTE with the CPE. (outer diameters of rotors are accordingly 200 and 160 mm). The methodology of performance calculation is similar to the one introduced in the works (12, 13) with some modifications.

Table 1

Parameters of working process and performance of the GTE – CPE by the variant I of circuit design (fig. 6)

η_{GTE}	N_{GTE} , kW	$\pi_{k\Sigma}$	π_{k1}	π_{k2}	Q_{CC1} , kJ/sec	Q_{CC2} , kJ/sec	Q_{reg} , kJ/sec	G_T , kg/sec	G_6 , kg/sec	T_T , K	T_6 , K	T_3 , K
$T_z=900K$												
0.233	46.2	6	2.63	2.28	149	30.3	0	0.160	0.3	900	406	666
0.253	48.8	8	3.01	2.65	142	36.4	0	0.150	0.3	900	430	639
0.262	49.7	10	3.35	2.98	136	42.6	0	0.143	0.3	900	449	618
0.265	49.9	12	3.66	3.28	131	46.3	0	0.136	0.3	900	466	602
$1100K$												
0.256	64.8	6	2.62	2.29	209	30.2	0	0.185	0.3	1100	407	816
0.279	69.5	8	3.00	2.66	202	36.3	0	0.178	0.3	1100	431	782
0.292	72.1	10	3.34	2.99	196	42.6	0	0.171	0.3	1100	450	756
0.299	73.5	12	3.65	3.28	191	46.3	0	0.166	0.3	1100	466	736

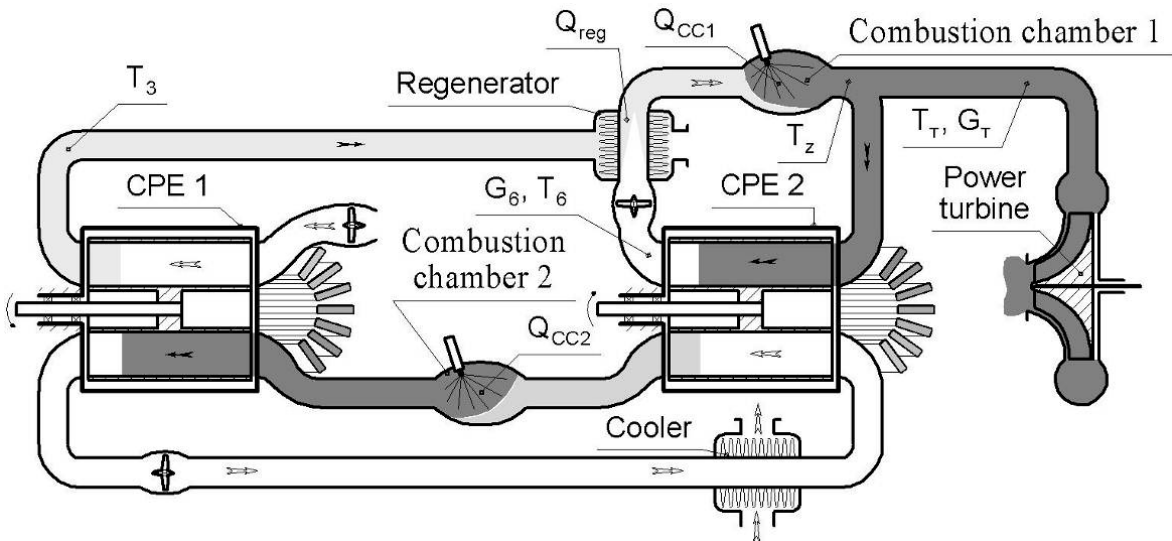

Fig. 7. Circuit design of the GTE with two stage cascade pressure unit and regeneration of the residual heat of the compressing gases

Рис. 7. Схема каскадного обменника давления с двухступенчатым каскадным блоком давления и регенерацией остаточного тепла при сжатии газов

It should be noted that relationship of compression degrees of air in first π_I and second stages π_{II} is not arbitrary. On the one hand the relationship is subordinated to condition of balance of charges of working mediums in lines of a high pressure of the first stage and low pressure of the second stage, on the other hand – to the condition of providing of scavenge and displacement of working mediums in the cells of rotors of both CPE. Generally the relationships π_I and π_{II} depend on the general pressure head of the thermal compressor π_K and the maximum temperature T_z of working cycle. The coordination of design values π_I and π_{II} for each investigated variant of a combination of parameters was attained by respective alteration of carrying capacity of the rotor of the CPE of the second stage by change of its rotational speed within the range from 1700 to 2800 min^{-1} .

Table 2

Parameters of working process and performance of the GTE – CPE
by the variant II of circuit design (fig. 7)

η_{GTE}	$N_{\text{GTE}},$ кW	$\pi_{\text{K}\Sigma}$	$\pi_{\text{K}1}$	$\pi_{\text{K}2}$	$Q_{\text{CC}1},$ кJ/sec	$Q_{\text{CC}2},$ кJ/sec	$Q_{\text{reg}},$ кJ/sec	$G_{\text{T}},$ kg/sec	$G_6,$ kg/sec	$T_{\text{T}},$ K	$T_6,$ K	$T_3,$ K
$T_z=900 \text{ K}$												
0.279	46.2	6	2.63	2.28	120	30.3	29.4	0.160	0.3	900	406	666
0.295	48.8	8	3.01	2.65	117	36.4	25.1	0.150	0.3	900	430	639
0.298	49.7	10	3.35	2.98	114	41.6	21.4	0.143	0.3	900	449	618
0.295	49.9	12	3.66	3.28	113	46.3	17.9	0.136	0.3	900	466	602
$T_z=1100 \text{ K}$												
0.304	64.8	6	2.62	2.29	171	30.2	37.8	0.185	0.3	1100	407	816
0.327	69.5	8	3.00	2.66	167	36.3	34.6	0.178	0.3	1100	431	782
0.337	72.1	10	3.34	2.99	164	41.6	31.7	0.171	0.3	1100	450	756
0.341	73.5	12	3.65	3.28	162	46.3	29.1	0.166	0.3	1100	466	736

The analysis of results of the GTE - CPE performance with the gas power turbine (tables 3 and 4) shows that the working process organization at the circuit design of variant II provides combination of high values of overall efficiency (η_{GTE}) and modular power (N_{GTE}). (Parameters $\eta_{\text{GTE}}=0.314$, $N_{\text{GTE}}=73.5\text{kW}$ are attained on regime $T_z=1100\text{K}$, $\pi_{\text{K}\Sigma}=12$). Due to heating of the compressed air in

the regenerator decrease of heat addition in the combustion chamber of the second (top) stage on this regime makes 15.2%.

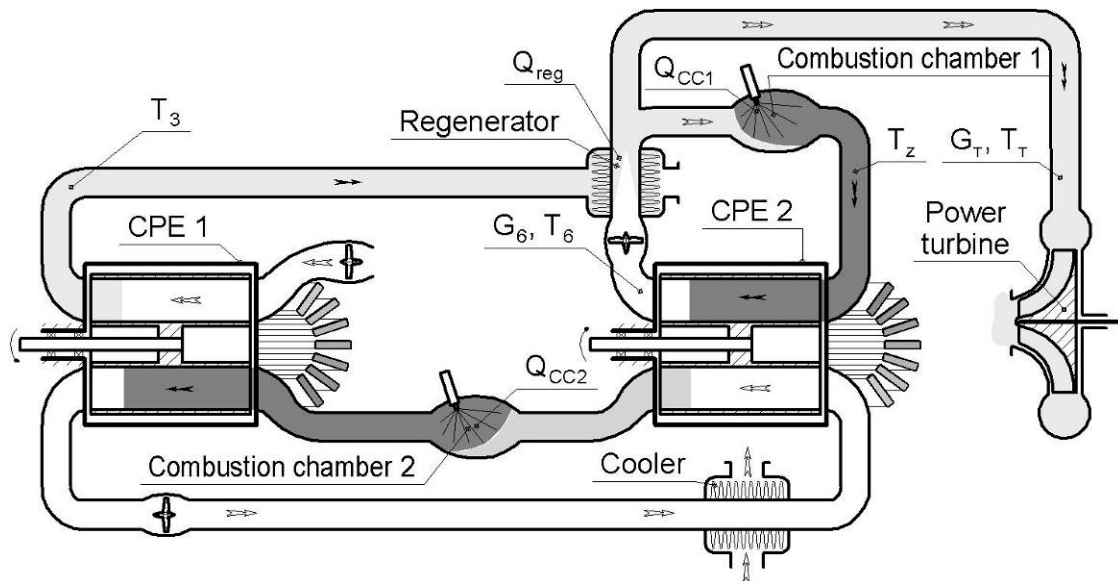

Fig. 8. Circuit design of the GTE with two stage cascade pressure unit and with air power turbine

Рис. 8. Схема каскадного обменника давления с двухступенчатым каскадным блоком давления и воздушной силовой турбиной

Advantages of a recuperative cycle are manifested in the greater degree, the higher the maximum temperature of cycle T_z and the lower the general compression ratio $\pi_{k\Sigma}$. So, at parameters $T_z=1000\text{K}$, $\pi_{k\Sigma}=6$ the regeneration provides a raise η_{GTE} at 19% (from 0.256 to 0.304), while at parameters $T_z=800\text{K}$, $\pi_{k\Sigma}=12$ raise η_{GTE} makes 7% at the expense of regeneration (with 0.234 to 0.251). At the same time, at choice of the GTE – CPE rational parameters we need to have in view the following regularities of working process:

1. Modular power increases with raise of $\pi_{k\Sigma}$ the GTE – CPE at the expense of increase in quantity of heat of an intermediate stage brought in the intermediate combustor, despite decrease of quantity of the heat brought in the top stage combustor.
2. The value $\pi_{k\Sigma}$, optimum by criterion of power inputs, depends on the maximum temperature of the cycle T_z . With raise of T_z an extreme overall efficiency is displaced in a direction of great values of $\pi_{k\Sigma}$, and at $T_z > 950\text{K}$ is in area of $\pi_{k\Sigma} > 12$. We notice that implementation of cycles with $\pi_{k\Sigma} > 12$ is interfaced to constructive complication of the GTE because of negative effect of leaks in rotors of the CPE and necessity of application of the multistage turbine.
3. For fixed values of T_z , the extreme overall efficiency of the GTE with regeneration (fig. 7) corresponds to smaller values of $\pi_{k\Sigma}$ relatively to the GTE - CPE without regeneration (fig. 8).

Decrease in effect of regeneration at raise of $\pi_{k\Sigma}$ is explained by approach of temperature of air compressed in the CPE to the maximum temperature of cycle T_z and by decrease of quantity of utilized heat. Therefore, the expediency of application of regeneration, in the final analysis, depends on the relationship of the maximum temperature of a cycle to ambient temperature. On the other hand, regeneration application, due to decrease in values of $\pi_{k\Sigma}$, allows to simplify the design of the power turbine and to lower working medium leaks through mobile conjugations of the flowing elements of the GTE.

Let's notice that the increase in the relation of boundary temperatures of the GTE – CPE cycle, as well as in classical GTE with the vane compressor is the key factor of raise of N_{GTE} and η_{GTE} . Possibility of essential raise of the maximum temperature T_z of cycle at conservation of rather sparing temperature working conditions of the power turbine is put in the circuit design on fig. 3. Here the working medium of the power turbine is the air compressed in the cascade exchanger and heated in the regenerator. The maximum temperature of the cycle is realized in a contour of the cascade

exchanger high pressure, promoting raise of the GTE overall efficiency on the whole while the working medium temperature in front of the turbine does not exceed the values of the residual temperature of gases which have been expanded in the CPE and have gone in the regenerative heat exchanger (see tab. 3). Overall efficiency of the GTE – CPE with the air power turbine at $T_z=1300K$ comes nearer to parameters of the GTE – CPE with the gas turbine and regeneration on regime $T_z=1100K$ (tab. 2), however, it concedes the last on modular power. In the same time the air temperature in front of the power turbine in the circuit design of variant III makes only 589K even at $\pi_{k\Sigma}=12$. Such appreciable decrease in thermal stress level of the flowing elements of the power turbine in the circuit design of variant III promotes decreasing the cost of the GTE plant and raise of a resource of its operation.

Table 3

Parameters of working process and performance of the GTE – CPE by the variant III of circuit design (fig. 8)

η_{GTE}	η_{GTE}	$N_{GTE},$ kW	$\pi_{k\Sigma}$	π_{k1}	π_{k2}	$Q_{CC1},$ kJ/sec	$Q_{CC2},$ kJ/sec	$Q_{reg},$ kJ/sec	$G_T,$ kg/sec	$G_6,$ kg/sec	$T_T,$ K	T_6 K
$T_z=900$ K												
0.248	25.9	6	2.63	2.28	56.0	30.3	29.4	0.160	0.3	503	406	666
0.255	27.8	8	3.01	2.65	58.1	36.4	25.1	0.150	0.3	513	430	639
0.251	28.8	10	3.35	2.98	60.1	41.6	21.4	0.143	0.3	520	449	618
0.243	29.1	12	3.66	3.28	61.9	46.3	17.9	0.136	0.3	525	466	602
$T_z=1100$ K												
0.294	31.7	6	2.62	2.29	65.6	30.2	37.8	0.185	0.3	532	407	816
0.305	34.9	8	3.00	2.66	68.2	36.3	34.6	0.178	0.3	545	431	782
0.305	36.8	10	3.34	2.99	70.5	41.6	31.7	0.171	0.3	555	450	756
0.300	38.1	12	3.65	3.28	72.6	46.3	29.1	0.166	0.3	563	466	736
$T_z=1300$ K												
0.320	36.1	6	2.60	2.30	73.1	30.1	43.6	0.203	0.3	552	407	965
0.334	40.2	8	2.99	2.67	76.2	36.3	41.1	0.196	0.3	567	431	925
0.337	42.9	10	3.34	3.00	78.9	41.6	38.9	0.191	0.3	579	450	894
0.335	44.8	12	3.65	3.29	81.3	46.3	36.9	0.186	0.3	589	467	870

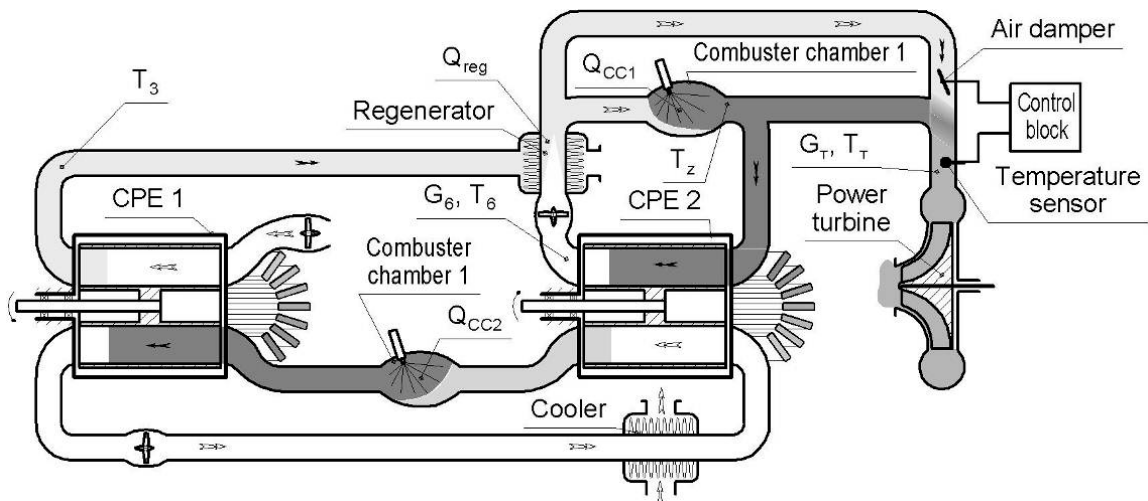

Fig. 9. Circuit design of the GTE with two stage cascade pressure unit and with mixing the gas and air flows in front of the power turbine

Рис. 9. Схема каскадного обменника давления с двухступенчатым каскадным блоком давления и смешиванием потоков газа и воздуха перед силовой турбиной

Perhaps the best circuit solution of the GTE - CPE by criterion of power efficiency is a combination of variants II and III, as in the circuit design of variant IV shown on fig. 9. In this plant

for the purpose of the further raise of the GTE economic operation the working medium temperature in front of the turbine is increased in addition and supported practically constant on the basic operating conditions of the GTE, within the restrictions of thermal stability of applied materials. Such regulating is carried out by a suitable diluting of hot gases with the compressed air by means of the by-passed channel with controlled lock body.

Forcing of the GTE - CPE working cycle on T_z with simultaneous optimization of temperature of air-gas medium in front of the power turbine allows to realize the highest power and economical parameters of the plant. So, at $T_T=900K$ raise of the maximum temperature T_z from 900K (tab. 3) to 1100K (tab. 4) promotes increasing η_{GTE} on 11,8% (with 0,295 to 0,33) and to raise N_{GTE} on 20% (with 49,9 to 60kW), and at raise of T_z from 900K to 1300K the rise of η_{GTE} and N_{GTE} accordingly makes 18% and 33%. On regime of $T_z=1300K$, $\pi_{k\Sigma}=12$, $T_T=1100K$ the GTE - CPE overall efficiency with mixing the gas and air flows in front of the power turbine attains the value 0,356.

Table 4

Parameters of working process and performance of the GTE – CPE
by the variant IV of circuit design (fig. 9)

η_{GTE}	η_{GTE}	$N_{GTE},$ KW	$\pi_{k\Sigma}$	π_{k1}	π_{k2}	$Q_{CC1},$ kJ/sec	$Q_{CC2},$ kJ/sec	$Q_{reg},$ kJ/sec	$G_T,$ kg/sec	$G_6,$ kg/sec	$T_T,$ K	T_3 K
$T_z=1100 K$												
0.301	53.0	6	2.62	2.29	134	30.2	37.8	0.185	0.3	900	407	816
0.321	56.9	8	3.00	2.66	132	36.3	34.6	0.178	0.3	900	431	782
0.328	59.0	10	3.34	2.99	130	41.6	31.7	0.171	0.3	900	450	756
0.330	60.1	12	3.65	3.28	129	46.3	29.1	0.166	0.3	900	466	736
$T_z=1300 K$												
0.312	57.3	6	2.61	2.30	144	30.2	43.6	0.203	0.3	900	407	965
0.334	62.1	8	2.99	2.67	142	36.3	41.1	0.196	0.3	900	431	925
0.344	65.0	10	3.34	3.00	140	41.6	38.9	0.191	0.3	900	450	894
0.348	66.8	12	3.65	3.29	140	46.3	36.9	0.186	0.3	900	466	870
$T_z=1300 K$												
0.312	70.1	6	2.60	2.30	185	30.1	43.6	0.203	0.3	1100	407	965
0.337	75.9	8	2.99	2.67	181	36.3	41.1	0.196	0.3	1100	431	925
0.350	79.4	10	3.34	3.00	179	41.6	38.9	0.191	0.3	1100	450	894
0.356	81.6	12	3.65	3.29	177	46.3	36.9	0.186	0.3	1100	467	870

4. CONCLUSIONS

Thermodynamic efficiency of the GTE – CPE is based on higher efficiency of transformations of heat in the combustion chamber to energy of compressed air concerning the working process of the classical GTE where air compression is carried out in the conditional turbo-compressor which is consisting of the vane compressor and part of the power turbine equivalent on power. In analyzed GTE - CPE installations rather insignificant power of an external source is spent for the drive of both CPE. The work of compression of air is carried out at the expense of internal redistribution of energy of gas flows in the flowing elements of the CPE units. Only the part of gas from the combustion chamber goes to the power turbine which, as a result, has essentially smaller sizes and developed power at equivalent power of the GTE. With decrease of the charge of gases (G_{out}) through the turbine the absolute power losses are reduced in it, therefore, imperfection of working process of the turbine including, on off-design conditions influences the GTE overall efficiency to the lesser degree. And, at last, noted above the insensibility of the working cycle of the CPE to incompleteness of displacement of compressed air from rotor cells at a deviation of its rotational speed and thermodynamic variables of working mediums from design values stipulates essential expansion of field of effective work of the GTE with the CPE.

Application of principles of the cascade compression of air-gas medium in the gas-turbine engine working cycle allows to improve significantly the traction and economic characteristics of the GTE and opens a prospect of wider application of the GTE in the capacity of ground transport power plants.

References

1. Mathis. G.P.: *Wave enhanced Gas Turbine Engine Cycles*. M. S. thesis, Cornell University, Ithaca, New York, 1991.
2. Wilson J. and Paxson D.E.: *Jet engine Performance Enhancement through Use of a Wave-Rotor Topping Cycle*. NASSA TM-4486, 1993.
3. Paxson D.E.: *A Numerical of the Startup Transient in Wave Rotor*. ASME J. Gas Turbines Power, 119(3), 1997, pp. 676-682.
4. Akbari P., Muller N.: *Performance investigation of small gas turbine engines topped with wave rotor*. 39th AIAA/ASME/SAE/ASEE Joint Propulsion Conference and exhibit 20-23 July 2003, Huntsville, Alabama, AIAA2003-4414, 2003.
5. Akbari P., Nalim M.R., Muller N.: *Performance Enhancement of Micro turbine Engines Topped With Wave Rotors*. ASME J. Eng. Gas Turbines Power, 128(1), 2006, pp. 190-202.
6. Akbari P., Nalim M.R., Muller N.: *A Review of Wave Rotor Technology and its Application*. ASME J. Eng. Gas Turbines Power, 128(10), 2006, pp. 717-734.
7. Meyer A.: *Recent Developments in Gas Turbines*. Journal of Mechanical Engineering, 69, No 4, 1947, pp. 273-277.
8. Weber H.E.: *Shock Wave Engine Design*. John Wiley and Sons, New York, 1995.
9. Mayer A., Oda J., Kato K., Haase W., Fried R.: *Extruded Ceramic – A New Technology for the Compres Rotor*. SAE Paper 890452, 1989.
10. Zehnder G., Meyer A., Mathews L.: *The Free Running Compres*. SAE Paper 890452, 1989.
11. Benini E., Toffolo A., Lazzaretto A.: *Centrifugal Compressor of A 100KW Micro turbine: Part I- Experimental and Numerical Investigation on Overall Performance*. ASME Paper GT2003-38152, 2003.
12. Rogers C.: *Some Effects of Size on the Performance of Small Gas Turbine*. ASME Paper GT2003-38027, 2003.
13. Welch G.E.: *Overview of Wave-Rotor Technology for Gas Turbine Engine Topping Cycles*. Novel Aero Propulsion Systems International Symposium, The Institution of Mechanical Engineers, London, 2000, pp. 2-17.
14. Крайнюк А.И., Сторчеус Ю.В.: *Системы газодинамического наддува*. Луганск: Изд-во ВУГУ, 2000, с. 224.
15. Kljus O.V., Krajniuk A.I., Alekseev S.V.: *The principle of organization of work process of cascade compression unit and its application*. Scientific journals Maritime University of Szczecin, 14(86), 2008, pp. 25-29.
16. Крайнюк А.И., Алексеев С.В., Брянцев М.А.: *Особенности рабочего процесса каскадного обменника давления*. Вісн. Східноукр. Нац. Ун-ту імені Володимира Даля, No 8(90), 2005, С. 176-179.
17. Krajniuk A.I.: *Thermal compressor of cascade exchange by pressure*. Silesian University of Technology, Faculty of Transport. International Scientific Conference. Transport Problems, Katowice-Kroczyse, 2009, pp. 186-191.
18. Крайнюк А.И., Крайнюк А.А.: *Новый принцип организации рабочего процесса систем кондиционирования воздуха железнодорожного и морского транспорта*. Silesian University of Technology, Faculty of Transport. VIII Scientific Conference Telematics, Logistics and Transport Safety, Katowice-Cieszyn, 2008, pp.64-68.
19. Брянцев М.А., Крайнюк А.А.: *Использование принципов каскадного обмена давлением в рабочем цикле газовых холодильных машин*. Двигатели внутреннего сгорания, Научно-технический журнал. Харьков, НТУ «ХПИ».No 1, 2008, С.-57-61.

20. Крайнюк А.И.: *Новые схемы и принципы организации рабочих процессов теплоэнергетических машин*. Вісник Східноукраїнського національного університету ім. В.Даля, Луганськ, Вид-цтво СНУ, 2010. - № 3 (145). Ч.2.- С.-187-204.
21. Крайнюк О.І., Крайнюк А.О.: *Генератор газів*. Патент UA No 36127, 2008.
22. Крайнюк А.И., Алексеев С.В., Брянцев М.А., Крайнюк А.А., Данилейченко А.А.: *Система наддува транспортного ДВС с каскадным обменником давления*, Вісник Східноукраїнського національного університету ім.В.Даля, Луганськ, Вид-цтво СНУ, No 7(125). Ч.2, 2008, с. 197-200.
23. Крайнюк А.И., Алексеев С.В., Крайнюк А.А.: *Система наддува ДВС с глубоким охлаждением наддувочного воздуха*. Двигатели внутреннего сгорания, Научно-технический журнал. Харьков, НТУ «ХПИ», №2, 2009, с. 59-65.

Received 04.02.2010; accepted in revised form 11.06.2011