

# Application of MEMS accelerometer for baby apnea monitoring under home conditions

## Zastosowanie akcelerometrów MEMS do monitorowania bezdechu niemowląt w warunkach domowych

Nina Tewel

Institute of Biomedical Engineering and Instrumentation, Faculty of Fundamental Problems of Technology, Wrocław University of Technology, Wybrzeże Wyspiańskiego 27, 50-370 Wrocław, Poland, tel. +48 507 93 13 49, e-mail: nina.tewel@pwr.wroc.pl

### Abstract

Sleep apnea episodes may cause potential baby's life threatening events and can be one of the first syndromes of other illnesses. Apnea is supposed to be one of the risk factors of Sudden Infant Death Syndrome (SIDS). Infant's breath monitoring and immediate apnea detection, not only in hospitals, but also under home conditions, increases the baby's safety and allow recognition of diseases at an earlier stage. This paper presents a model of new device for detection of apnea, consisting of a three-axis MEMS (Micro Electro-Mechanical Systems) accelerometer with digital output, microprocessor and some alarm instruments. The device allows the monitoring of both, the breathing movements of the child's abdomen, as well as the vibrations of the abdominal wall associated with the heart action and enables early detection of central and obstructive apnea. Another useful application of the described model is the possibility of monitoring the baby's position during sleep. The paper presents the hardware, apnea detection procedure and the performance of the physical model of the apnea monitor.

**Key words:** SIDS, infant apnea, MEMS accelerometer, respiratory monitoring, heart rate monitoring

### Streszczenie

Bezdech senny stanowi potencjalne zagrożenie życia niemowląt i może być pierwszym syndromem innych schorzeń. Jest on uznawany za jeden z czynników ryzyka Zespołu Nagłego Zgonu Niemowląt (SIDS – *Sudden Infant Death Syndrome*). Monitorowanie oddechu niemowląt i szybkie rozpoznawanie stanów bezdechu nie tylko w szpitalu, ale także w warunkach domowych, zwiększa bezpieczeństwo dziecka i ułatwia wykrywanie innych chorób w ich wczesnym stadium. Przedstawiony artykuł opisuje model nowego urządzenia przeznaczonego do wykrywania bezdechu, zbudowanego z akcelerometru MEMS (*Micro Elektro-Mechanical Systems*) o trzech osiach czułości z wyjściem cyfrowym, mikroprocesora i elementów alarmujących. Urządzenie monitoruje ruchy oddechowe dziecka i wibracje ściany brzucha towarzyszące pracy serca, przez co umożliwia szybkie wykrywanie zarówno bezdechu centralnego, jak i obturacyjnego. Inną użyteczną funkcją prezentowanego modelu jest możliwość kontroli pozycji dziecka podczas snu. W artykule opisano układ, procedurę detekcji bezdechu oraz pierwsze wyniki uzyskane z wykorzystaniem przedstawionego modelu monitora.

**Słowa kluczowe:** SIDS, bezdech niemowląt, akcelerometr MEMS, monitorowanie oddechu, monitorowanie tętna

### Introduction

Due to the immaturity of breathing and neural systems even full term and seemingly healthy infants are at risk of some life threatening events such as the sleep apnea. Apnea is supposed to be one of the risk factors of Sudden Infant Death Syndrome (SIDS) which concerns newborns and infants aged 1-6 months [1]. The respiratory disorders can be either the main reason of sudden death or a syndrome associated with another life threatening episode. In other cases apnea events may accompany other serious illnesses even at their early stage [2]. According to this information, monitoring of the infant's respiration helps to decrease the risk of SIDS and protect the baby's health. Immediate detection of apnea enables either a quick life-saving action in case of life threatening event or an early recognition of some diseases. This kind of protection is especially important under home conditions.

The term of apnea describes in fact a variety of episodes and the course of each event depends on its cause [1]. In case of the central apnea the primary reason for the event is a long breathing action standstill. A time of 10-20 s is assumed to be the limit between the physiological apnea of pre-term infants and a pathological episode. The central apnea is caused by the immaturity of the infant's neural system and can be detected in a simple way by monitoring respiratory movements [3-11]. However, performance of this easy method is rather poor in the case of obstructive apnea caused by a respiratory tract occlusion. In cases of this kind of disorder respiratory movements do not disappear before the final stage of the event when the life threat is serious and at an early stage of the apnea they can even become more intensive. The available devices for apnea monitoring under home conditions can detect only respiratory movements so in fact they do not protect children against obstructive apnea.

Another syndrome associated with apnea is bradycardia. For infants the physiological heart rate is ca. 110-160 beats per minute [1] or more and bradycardia occurs when it decreases to a value lower than 80 beats per minute so the difference between physiological and pathological value is clear and easy to detect. Bradycardia accompanies every kind of apnea so the possibility of additional heart action monitoring would improve the performance of home baby's breath monitors and make the devices more reliable.

There are several well known clinical methods of monitoring both the respiratory and heart rate of infants. However, none of them is appropriate for long term monitoring under home conditions [5]. All those methods are uncomfortable for infants and their application can be too difficult for parents. The main purpose of the presented research was to design a new, possibly inexpensive, portable and practical baby's breath monitor enabling both respiration and heart ra-

te monitoring in a simple way and without disturbing the child.

Good performance of vibration sensors in detecting respiratory movement and the vibration associated with heart action has been proved during some clinical researches. In the case of the existing solutions, either the mattress with a number of accelerometers [12, 13] or the device with a single three-axis sensor [14] is a part of a more sophisticated and expensive system intended for typically clinical applications. The described monitor consists of only one acceleration sensor and a simple supervising circuit, and it works without any PC connection or another external equipment. As in the case of some available monitors [15] the device with the accelerometer is fixed to the baby's nappy or clothes in the region of abdomen. The sensor detects all movements and vibration of the abdominal wall. Another advantage of using an accelerometer is the possibility of monitoring the baby's position by measuring the static acceleration. It has been proved that the wrong position during sleep increases the risk of apnea and SIDS [1]. In most cases the supine position is believed to be the safest.

### Method and instrumentation

The described investigations [16-18] can be divided into two phases. At the first stage data was collected in three axes of sensitivity. The obtained signals were used to complete information about the range and frequency spectrum of the measured acceleration and to work out a method of filtering and analyzing the respiratory and heart components. The second stage of the experiment contains some tests of a physical model of the monitor. During all of the experiments the subjects were lying in a supine position and any other position was not considered. This simplification is appropriate for the majority of the youngest infants who usually do not change their position during sleep.

The first experiments were performed on adults. The sensor was fixed to their clothes in the region of abdomen and some data was collected. The subjects were breathing ca 30 times per minute in order to simulate the child's breathing rate or holding their breath for a time longer than 15 s. That period of time was assumed to be the limit between physiological and pathological apnea. The data were collected in a state of rest when the heart rate of an adult was ca. 80-90 beats per minute and after some physical exercise when it increased. The measurements were also repeated on some sleeping children and the data for infants and adults were compared. Finally a physical model of the monitor was constructed. The signal processing algorithm was optimized and tested both on adults and infants. The additional tests were also performed on the model device lying motionless on the ground.

The location of the device on the volunteer's or child's abdomen is shown in fig. 1. At the early stage of the experiments the basic circuit of the monitor was additionally connected to a PC. The PC software was developed in LabWindows CVI and enabled the collection, visualization and analysis of the observed signals and optimization of the algorithm. The performance tests of the physical model and the final version of the signal processing algorithm was carried out without connecting the PC.

The block diagram of the measurement set is shown in fig. 2. The basic circuit of the monitor consists of a three-axis accelerometer with a digital output (LIS3LV02DL [19]), a simple microcontroller (ATtiny2313) and some alarm elements, such as buzzers or LEDs. The more detailed diagram of the circuit is given in fig. 3. The buzzer is used as an alarm and the LEDs signalize every single breath and heart beat. Adding the diodes is not essential but it makes the circuit's performance tests easier. Photographs of the device used during the experiments are shown in fig. 4.

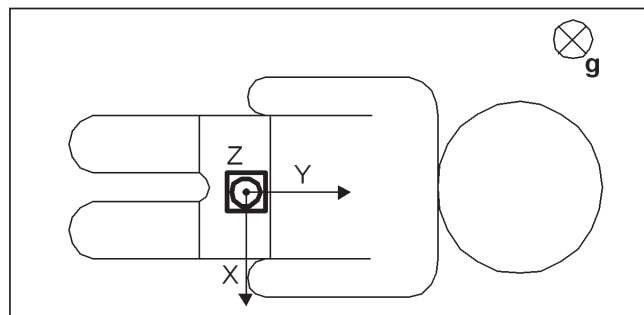

Fig. 1 The location of the monitor. Sensitivity axes of the accelerometer and the direction of the acceleration of gravity are marked

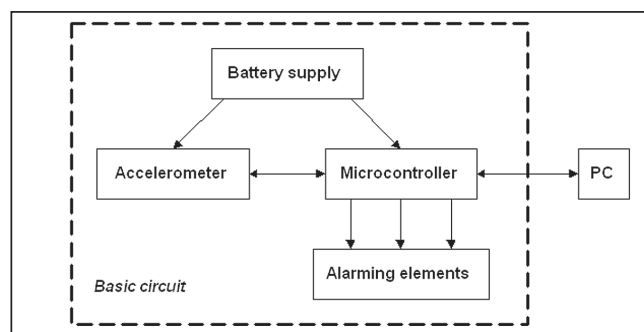

Fig. 2 The measurement set with additional PC connection

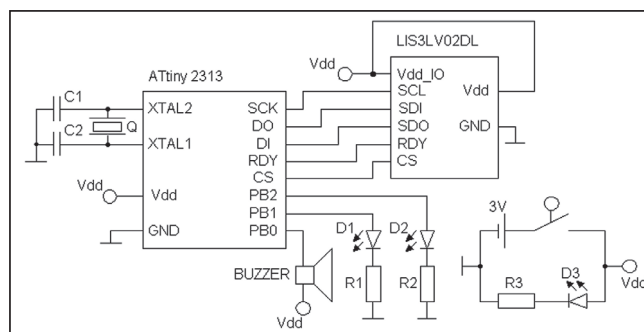

Fig. 3 The detailed circuit diagram of the monitor. LEDs D1 and D2 signalize breathing and heart action



Fig. 4 The prototype of device used during experiments

Fig. 5 shows the block diagram of the signal processing algorithm. It is a simplified version of the final solution and it works well only in the special case, of the supine position and the coordinates of sensor's axes shown in fig. 1. These assumptions allow for the use the results of measurements from only two axes. Despite some simplifications the presented example shows very well the main concept of the applied signal processing.

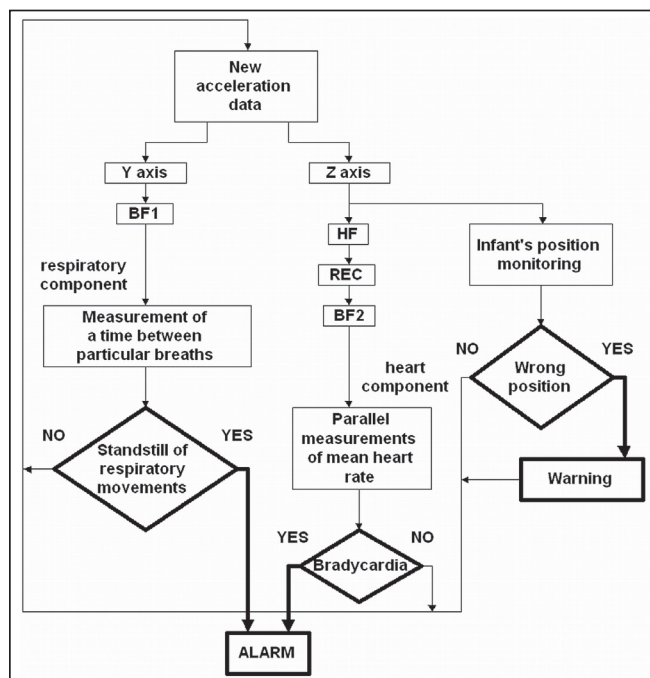

Fig. 5 Algorithm of the signal processing method. BF – band pass filters, HF – high pass filter, REC – rectification

The respiratory and heart components of the signal have different frequency spectra so they can be separated easily by using digital filtering. First order infinite impulse response Butterworth filters were used for this purpose. In this way the bandwidth of the accelerometer was limited to 10 Hz which reduced noise and increased resolution. In the simplified version of the signal processing algorithm the respiratory component is supposed to be observed mainly in the Y channel and the heart component in the Z channel, so during detection of both components the data from only one channel needs to be considered.

In case of respiration the signal is detected by measurement of the static component. This component of the measured signal depends on the angle between the Y axis of the accelerometer, which fluctuates while breathing and the direction of the gravity vector. After band pass filtering the signal can be modeled as a sinusoid and separation of particular breaths is possible by detecting the zero value. In order to detect respiratory disorders the period of time between consecutive breaths is measured. A breathing standstill longer than 15 s is interpreted as an apnea.

The frequency spectrum of the heart component of the observed signal is larger because every heart beat causes a series of damped vibrations of the abdominal wall. In this case the dynamic component of the acceleration data are used. The analysis algorithm consists of three stages. In the beginning the vibrations are separated from the Z axis signal by high pass filtering. Then the signal is rectified. In the final stage particular beats are separated by band pass filtering. An approximate value of heart rate is determined by counting the number of heart beats in 15 s. In order to speed up the detec-

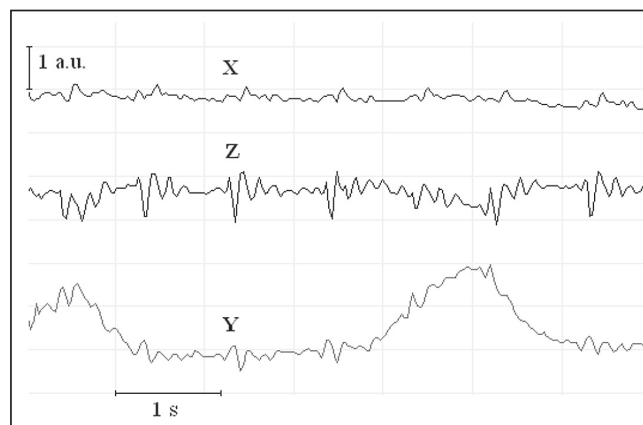

Fig. 6 The measured acceleration in three sensitivity axes for the device fixed in the region of abdomen of an adult person. For the position shown in fig. 1 the respiratory component is observed in Y axis and the heart component is clearest in Z axis [16]

tion of apnea two parallel measurements are carried out and the second one starts 7.5 s later than the first one. When the number of counted beats during a single measurement is smaller than 21, bradycardia is detected. In case of detection of respiration movements disappearance or bradycardia an alarm is launched. The monitor stops working and the alarm is active until reset.

The cutoff frequencies of the band pass filters enable separation of particular breaths (BF1) or beats (BF2) were chosen on the basis of a set of certain medical data and they are given in table 1. The performance of these filters was tested on some collected data. The cutoff frequency of the high pass filter (HP) depends on the frequency of abdominal wall vibration associated with every beat of the heart. The frequency band of those vibrations was determined on the basis of the collected data.

The analysis of the static component of the Z axis signal also enables detection of the child's position. For the coordinates shown in fig. 1 when the subject is lying in the supine position the angle between gravity and the Z axis is ca 180°. This angle changes with the position of the infant. If the detected change exceeds 45°, the warning alarm is launched. The monitor keeps working but because of the described simplification its performance is poor.

## Results

An example of data collected during the experiments performed on adult volunteers are shown in fig. 6. For the coordinates shown in fig. 1 the breathing component is observed only in the Y axis. The heart component is the clearest in the Z axis but it appears also in other axes. In all cases the changes of acceleration were quite small (10-20 mg) but the accelerometer used was sensitive enough to detect them.

Figs 7 and 8 show the results of consecutive stages of the signal processing algorithm for data for an adult person. According to the figures the applied procedure enables the separation of particular breaths and heart beats. The perfor-

Table 1 Medical data connected with respiratory and heart signal and cutoff frequencies of band pass digital filters [1]

Type of component	Medical data [breaths/beats per minute]	Stage of filtering	Lower cutoff frequency [Hz]	Upper cutoff frequency [Hz]
Respiratory rate	30-60	BF1	0.45	0.9
Heart rate	physiological rate: 110-160 bradycardia: 80 and lower	BF2	1	3

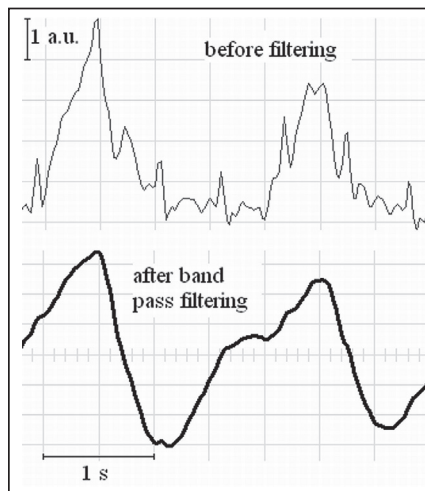

Fig. 7 The performance of signal processing algorithm – respiratory component [16]

mance of the procedure for heart beat separation was tested for different values of the high pass filter's cutoff frequency. Finally the value of 7.5 Hz was chosen.

Signals collected for adults were compared with the data obtained for children. The algorithm was also tested on some data collected for infants. The signals are shown in fig. 9. The analysis of data collected for adults and children gives the relationship between the amplitude of vibrations corresponding to the heart action and the age and size of the subject. The influence of heart action on the signal in all axes decreases with the age and size of the subject. For infants the abdominal wall's vibrations are weaker than for older children and adults, which makes the heart action detection more difficult and increases the influence of motion artifacts. The applied algorithm usually enables the separation of particular beats also in case of infants. However its performance is not as good as for adults because some beats are multiplied and some are missed. The ability of detecting particular breaths also depends on subject's size and age but in this case a decrease of size improves the performance of the algorithm.

Tests performed with the physical model of the monitor confirmed the results of the collected signals analysis. The monitor enables detection of central and obstructive apnea simulated by adult persons. Despite the weakness of the abdominal wall's vibrations associated with heart action of infants the model detects both breaths and heart beats. The accuracy of heart rate measurement was quite poor but sufficient to recognize the physiological heart rate of 110 beats per minute and bradycardia. During these experiments no false alarms were observed.

For the model lying on the ground an apnea was detected and alarm was launched as the observed respiratory signal was constant. This result means that the algorithm of the monitor is resistant to environmental vibrations. However, the influence of the child's movement on the detected signal is clear. During all investigations detection of a wrong position worked properly.

## Discussion and conclusion

Generally, the presented results confirm the good performance of the described method of both central and obstructive apnea detection. The applied measurement circuit and algorithm

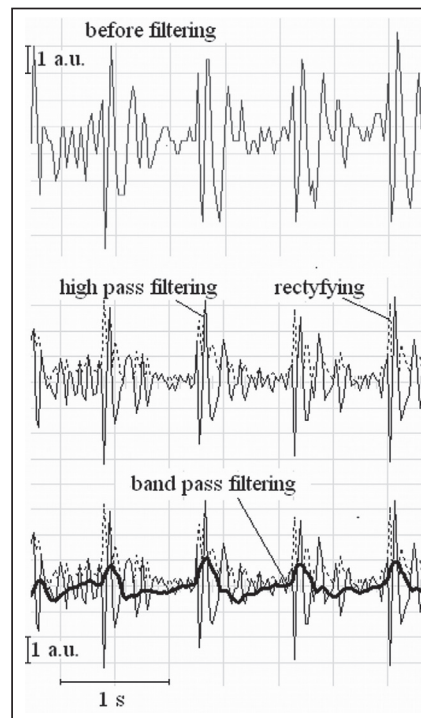

Fig. 8 Performance of the signal processing algorithm – three stages of heart beats separation [16]

enables separation of particular breaths and heart beats for all of the examined subjects. The simulated apnea is detected and during tests with healthy infants no false alarm was generated in spite of the small amplitude of the heart component of the signal and some motion artifacts. The lack of respiratory signal is detected despite environmental vibration and the approximate measurement method of heart rate enables recognition of a pathological state and bradycardia. The monitor's ability to detect the weak vibrations of the infant's abdomen associated with heart action can be improved by replacing the applied accelerometer with a device with better resolution. The presented device is also portable, easy to use and quite inexpensive.

During experimental examinations only a simplified case was considered. The subjects were laying in the supine position and the monitor was fixed in the same way so the axis direction and the angle between X axis and earth acceleration vector did not change. In the general cases the monitor can be fixed to the nappy each time in a slightly different way and infants can change their sleep position. Those changes are not as significant as in the case of an adult so the applied simplified method gives good results. However, in the most general case detection of the breathing and heart action can be performed for each sensitivity axis what should improve the performance of the monitor for different positions. The prone position is the only exception because it disables the detection of abdominal wall's movements and vibrations. That limitation is typical for small monitors fixed to the baby's nappy. However it has been proved that the prone position increases the risk of SIDS so it is recommended quite rarely.

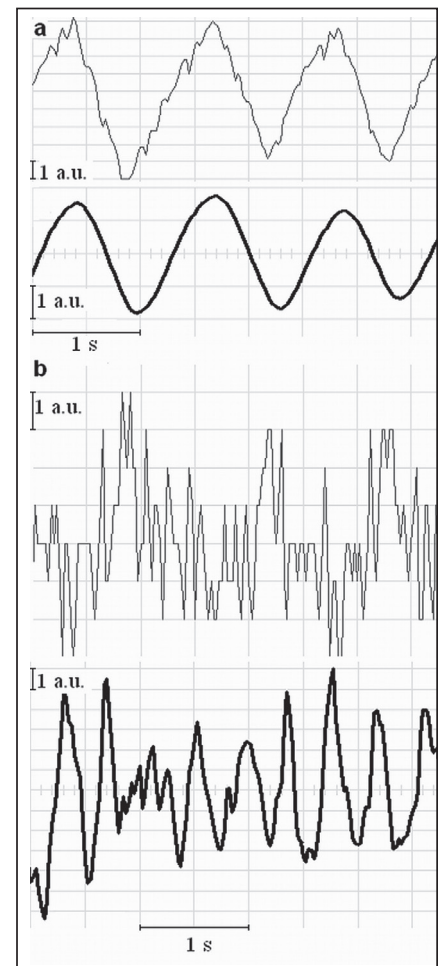

Fig. 9 Respiratory (a) and heart (b) component of a 2 months old infant before (upper, thin lines) and after signal processing (lower, thick lines) [16]

To sum up, the described method of apnea detection seems to be very promising because of the additional heart rate monitoring and quick obstructive apnea recognition without disturbing the infant. Another advantage is the possibility of detecting the unsafe position of the infant. The next stage of investigation should contain some clinical tests of a model. The described experiments should be repeated on infants with sleep apnea in order to confirm the ability of the device to recognize respiratory disorders. ■

## References

1. M.G. Mac Donald, M.M.K. Seshia., M. D. Mullett: *Avery's neonatology*, Lippincott Williams & Wilkins, Philadelphia 2005.
2. C. Linti, H. Horter, P. Österreicher, H. Planck: *Sensory baby vest for the monitoring of infants*, *Wearable and Implantable Body Sensor Networks*, BSN 2006, p. 135-137.
3. B.H. Brown: *Impedance pneumography*, U.S. Patent 6,015,389, 2000.
4. J. Bunker, M. Kejuwal, G. Monlux: *Sids home monitor with telecommunications capabilities*, EMBS, 1993. Proc. of the 15th Annual International Conference of the IEEE, p5. D. Dobrev, I. Daskalov: *Two-electrode telemetric instrument for infant heart rate and apnea monitoring*, *Med. Engineering & Phys.* vol. 20, 1998, p. 729-734.
6. R.S. Leder, K.P. Cohen, N. Peterson, S. Palreddy, C. Green, W. Tompkins, J. G. Webster: *Performance of impedance and inductance ventilation sensors on premature infants during natural breathing, motion and airway obstruction*, EMBS, 1993. Proc. of the 15th Annual International Conference of the IEEE, vol. 4, San Diego, CA, USA, Oct. 28-31, 1993, p. 3094-3097.
7. W.H. Lawson: *Infant bed and apnea alarm*, U.S. Patent 4,146,885, 1979.
8. M.R. Neuman, T.G. McIntyre: *Strain gauge and method of making and using the same*, U.S. Patent 5,079,535, 1992.
9. S.D. Pearce: *Transducer for detecting apnea*, U.S. Patent 4,971,065, 1990.
10. D.L. Stephens: *Breathing monitor articles of wearing apparel*, U.S. Patent 5,454,376, 1995.
11. P.K. Sullivan: *Passive apnea monitor*, U.S. Patent 6,375,621, 2002.
12. D.C. Mack, M. Alwan, B. Turner, P. Suratt, R.A. Felder: *A passive and portables for monitoring heart rate and detecting sleep apnea and arousals: preliminary validation, distributed diagnosis and home healthcare*, 2006. D2H2. 1st Transdisciplinary Conference, Arlington, VA, USA, Apr. 2-4, 2006, p. 51-54.
13. D.C. Mack, S.W. Kell, M. Alwan, B. Turner, R.A. Felder: *Non-invasive analysis of physiological signals (NAPS): a vibration sensor that passively detects heart and respiration rates as part of a sensor suite for medical monitoring*, 2003 Summer Bioengineering Conference, FL, USA, Jun. 25- 29, 2003, p. 1071-1072.
14. T. Grysiński: *The system for non-invasive monitoring of a patient's movement activity during sleep* (in Polish), PAK vol. 9bis, 2006, p. 134-136.
15. C.D. Silva: *Device for monitoring respiratory movements*, U.S. Patent 0015457, 2007.
16. N. Bania: *Instrument for infant apnea monitoring for home use* (in Polish), MSc Eng. thesis, Wrocław University of Technology, Wrocław, Poland, 2008.
17. N. Bania: *Device for monitoring apnea of infants under home conditions* (in Polish), *Metrology today and tomorrow* (in Polish), Gdańsk, Poland, Aug. 31-Sep. 02, 2009, p. 401-409.
18. N. Bania, E. Nowaczyk, Z. Moroń: *Infant apnea monitoring method and device* (in Polish), Polish Patent Application P386734, Dec. 08, 2008.
19. Datasheet of the device LIS3LV02DL <http://www.st.com/internet/analog/product/127514.jsp>.

otrzymano / received: 03.10.2010 r.  
zaakceptowano / accepted: 22.11.2010 r.