

# Telemetric system for track measurement in rails vehicles without electric power supply

**T. HEJCZYK**

WASKO S.A., Berbeckiego 6, 44-100 Gliwice, Poland

EMAIL: t.hejczyk@wasko.pl

## ABSTRACT

The article presents review of methods and devices for track measurement of rail vehicles in aspect of diagnostics and safety of use. Currently used solutions do not enable effective “on-line” measurement of mileage by wheelsets and vehicles’ axles in rail vehicles without electric power supply such as goods wagons and cisterns. Those solutions have limited functionality and have to use additional power supply (accumulators, generators, etc.) which significantly increase exploitation costs. A telemetric system for monitoring of wheelsets’ mileage as well as of their bearing temperature, based on original solution of odometer installed on the set’s grease-box, was suggested in the research. The odometer is powered from an independent source of energy generated through magnetic induction by coil and neodymium magnets. Reading of collected data is done with the help of a PDA equipped with an RFID reader as well as wired and wireless interfaces for data transmission to telemetric system and GPS.

**KEYWORDS: wheelsets, axles, wagons, diagnostics, mileage, bearing temperature, lack of electric power supply, odometer, telemetry**

## 1. Introduction

The safety of traffic control of rail vehicles requires continuous mileage’s monitoring of rail vehicles, wagons, and particularly mileage control of wheelsets, wheels and axles. Supervision should assure control of used materials. Depending on wagon’s mileage, the necessity of rims regeneration or bearing inspection based on previous bearing temperature measurement can occur, so that used material does not become the cause of train’s failure. To prove that it is not only a theoretical problem, it is enough to mention among other things a rail catastrophe in Viareggio on 29<sup>th</sup> of June 2009, where due to breakage of axle of a cistern transporting liquid gas 15 people were killed and over 50 were injured. As a result of this accident European Railway Agency as well as European Commission formulated recommendations and guidelines regarding axle and wheelsets diagnostics [1].

This measuring problem is especially hard to solve in case of exploitation of goods wagons which often transport dangerous loads and in contradistinction to railway-engines and passenger wagons are free of electric power supply. To provide correct wagons and wheelsets exploitation it is also necessary to have information about actual mileage of wagon and its wheelsets, even in the situation when it was dismantled and stored. The legislator lays [2], [3], [4], [5] a duty of rails vehicles’ mileage monitoring, which also determines validity of certificate of admission to rail traffic. However, in current regulations the method of calculation as well as technical requirements for the counter have not been specified.

The aim of this study is the analysis of currently used solutions in this field and suggesting the system which would monitor mileage of wagons and wheelsets with particular consideration of rail vehicles without electric power supply.

## 2. The analysis of existent solutions of kilometer counting methods and distribution of these data

### 2.1 Mechanical kilometer counters – method no. 1

Information about mechanical devices being kilometer counters was included in patent description in 1934. For this purpose appliances with ratchet and pawl mechanism were used driven by eccentric and driving the counter. The following solution was suggested by Siemens-Schuckertwerke. The first practical method of mileage measurement of goods wagons and its registration is mechanical counter. Devices from DIBA4000 series of Ditzinger trademark are based on this method. Those devices are built on axle in a way that enables its bearing. Thanks to non-centric placement and fixing they stay in set position toward turning wagon's axle [6]. The fundamental disadvantage of these devices was low durability due to shakes and hits. The precision of such counters was worsening due to appearing vibrations. Readings of the counters achieved by this method were stored in the form of paper documentation.

### 2.2 Electromechanical tachometers – method no. 2

One of the ways of counting the distance is the method based on electromechanical counters e.g. Hasler RT/A type, which are installed in engine-driver's cockpit [7]. It is not a direct way of measurement, however it allows to estimate the mileage of attached wagons based on the mileage of railway-engine during its work. Documentation can be done in the form of paper consignment note. There is also no possibility of electronic transfer of data "on-line" to central point of data collection, for example central data base including information about mileage.

### 2.3 Electronic tachometers – method no. 3

The method allowing for the mileage counting are systems built on electronic tachometers, where wagon's mileage measurement is calculated indirectly, that is based on the readings of the counter of the currently attached railway-engine.

There are many types of electronic tachographs offered on the market, however the interesting one is e.g. Teloc 1500/2500 [8], which is a modern solution based on computer data recording from the ride with the possibility

of wide analysis of collected information by means of a PC. The devices are installed on railway-engine. This way of ride's acquisition and registration meets all the latest safety requirements as well as European Commission's standards. Described above tachograph Teloc has a certificate issued by Railway Transport Office and fulfills all requirements of ERMTS and ETCS systems.

As an indirect measurement system it is not suitable for monitoring of wheelsets. Also due to required power supply ranged between 24 and 110VDC, unavailable in goods wagons. However, for further consideration it is possible to assume a change in tachometer's construction which would allow its installation on every type of wagon or wheelset enabling direct measurement of their mileage. At that time it is necessary to provide electric power supply (batteries, generator coupled with wagon's axle, etc.). it is possible to use for that purpose for example encoders installed on the lid of the bearing. The method is easy in implementation but at the same time expensive due to necessity of providing electric power supply, and in case of using accumulators it would cause significantly high exploitation costs.

On the market there are also present electronic tachometers which are designed to measure rotations with the help of magnets and REED-Relay. Their characteristic is a small compact construction, unfortunately they require battery power supply, which in case of the situation when a wheelset has not been used for a long period of time excludes its long-term use. Since the precision of the results in this method is influenced by accuracy in fixing the actual diameter of the wheel (which changes with the passing of time), it requires introduction of possibility of its flexible programming. It causes the need of expanding electronics and as result it increases consumption of energy.

### 2.4 Measurement of mileage based on GPS - method no. 4

The methods of kilometer control with the help of systems using GPS/DGPS depend on calculating the wagon's mileage on the ground of summing up in time distances between points indicated by GPS. They use indirect system of calculation. The fundamental function of such systems is location of rolling stock on the map. These systems also often monitor other parameters of railway-engine's work (e.g. status of railway-engine's work and goods wagons attached to it, significant parameters of its exploitation, fuel consumption, engine's driver log in and his time of work as well as fast access to reports, statistics and data sheets). There is also a function of full visualization of the track and stops history. This information is sent to Central Monitoring Unit in real time, for example with interval of 1 s. and back – from Central Monitoring Unit to the

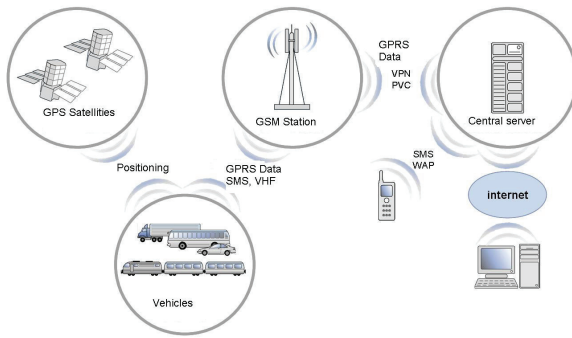

**Fig.1. The concept mileage counting system by means of GPS**

Source: [12]

objects with use of package of data transmission and infrastructure of GSM [9].

The standard accuracy of GPS from technical perspective gives precision of range of a few meters however the track calculation is loaded with much bigger error due to approximation curvature of the route with a straight line. The way of increasing accuracy of the measurement is usage of the system which works based on forward differencing method DGPS. In such cases, receiver located near the base station (with known and constant position) DGPS transmits to it differencing data (most often it is the difference between para distances calculated by BTS and real distances to the satellites). That way GPS receiver can correct errors coming from propagation of the signal between the satellite and the receiver.

Other error correction system is WAAS/EGNOS, similar to DGPS with the difference that corrections are sent to receivers by geostationary satellites. Moreover, specific countries have their own local networks of reference stations allowing for "on-line" or "post-processed" correction of the position fixed by GPS. In Poland such network is known as ASG-EUPOS (Active Geodesic Network EU-POS). The system allows for locating with the use of GPS-RTK with the accuracy of reading of 3 cm horizontally and 5 cm vertically. On the other hand, "post-processed" accuracy reading in POZGEO and POZGEO-D systems can range 1 mm.

## 2.5 System integrated with SEPE (Exploitation Work Registry System)

One of the methods of rail vehicles' locating is using IT system integrated with SEPE (System Ewidencji Pracy Eksploatacyjnej - Exploitation Work Registry System). The system belongs to the same family as GPS described in point 2.4. Currently PKP Przewozy Regionalne uses System Zarządzania Flotą (Fleet Management System) – DS Locate by

Data System. It enables locating and monitoring PKP's rolling stock. Thanks to integration of DS Locate system with SEPE the tasks requiring manual work and high labour inputs were automated. DS Locate system works "on-line", which means that all signals from vehicles are regularly sent in constant short intervals and additionally in case of unexpected event. SEPE application allows PR's controller to find position of a specific vehicle based on its serial number and train number. It allows also to obtain many more additional data about the vehicle (e.g. current speed, accurate time and location of the vehicle and possible delay). Data are archived. SEPE system allows the controller to manage the rolling stock in a dynamic way and to view current state of fleet "on-line". The system has a complex functionality supporting fleet management. However, it does not enable mileage registration of wagons and wheelsets.

## 2.6 Numerical wagon documentation – method no. 6

Kilometer calculation is done based on shipping notes R7 and other documents prepared by traffic control staff. By reason of regulations which requires from rail transportation companies control of distance covered by rail vehicles and by the fact that goods wagons are not originally equipped with kilometer counters, enterprises use by their own means procedures which in most cases are based on analysis of shipping notes and other documents. However, these procedures are unreliable and inaccurate because of the need of manual updates and copying.

Full realization and registration of wagons' registry rules are basic responsibilities of all PKP units employees who deal with management of goods wagons or using wagons. Its observance allows to avoid missing of wagons, result errors in railway stock work and loss of railway.

Even though transportation companies constantly improve the procedures of writing out, flow and archiving shipping documents (they include information about the length of covered distances), they still require a lot of time and staff. Fixing the mileage of wheelset (wagon, rail vehicle, etc.) based on assumption of distance from first to last station is only estimation and the results are not available in real time.

## 2.7 Conclusion

Collected information and knowledge about devices and systems registering rail vehicles' mileage were analyzed from the perspective of possibility of implementing them in a large-scale in rail vehicles without electric power supply, which are mainly goods wagons caused by lack of such tools. The existing solutions listed above are usually unsuitable for direct implementation in case of wagons without electric power

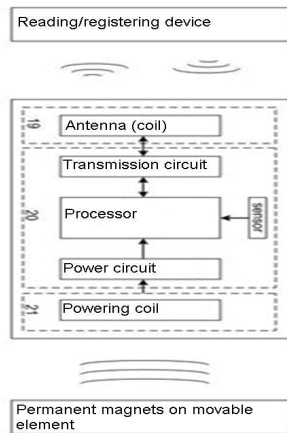

Fig.2. Block diagram of odometer

Source: [12]

supply, that is why it is advisable to develop a completely new device for the purpose of mileage calculation in wheelsets. Such a device together with suitable software should allow for the selection of wheelsets in order to point questionable or used element before it causes an accident.

### 3. The concept of telemetric system for measurement data collection

Under the agreement between the Ministry of Science and Higher Education for subsidy of targeted project no. 422/BO/A “Developing and implementing a device supporting diagnostics of rail platforms transporting

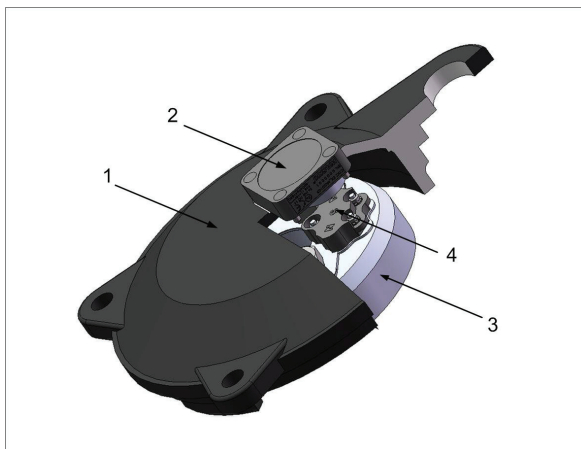

Fig.3. View of the device, 1) lid of the grease-box, 2) Odometer, 3) Rotating ending of the axle, 4) magnets.

Source: [12]

dangerous loads” [12] WASKO SA and Silesian University of Technology developed a concept of telemetric system for measurement data collecting regarding mileage of wagons and wheelsets in rails vehicles without electric power supply. A prototype of the system has been developed and made for this purpose.

### 3.1 Odometer

The basic element of the system is an odometer, that is a device allowing for the measurement and control of distance covered by wagons and rail vehicles. It has an original construction with independent local renewable electric energy source, based on induction of electromotive force in coil of kilometer counter placed in extremely low frequency magnetic field and resulting from rotation of neodymium magnets located in the wagon’s wheel. It is installed on grease-box of the wheel. Thanks to axle rotation it produces enough energy to power micro-controller counting the amount of axle’s rotations and being able to register this value in non-volatile memory. Besides, the mileage it also registers current wagon’s bearing temperature and stores data about wagon which are necessary to prepare shipping notes. Reading and input of data are done from the controller in the form of PDA. Two-way data transmission takes place in the form of radio signal to/from the counter. Blocked diagram of the device is presented in Fig. 2 and its view in Fig. 3.

Non-contact data reading does not affect the reading because of dirt and non-volatile memory circuit is powered wireless by the controller at the moment of reading/registering of data. Energy needed for emitting electromagnetic wave is taken from the wave of the device that reads the data (so the vehicle does not have to be in motion) and it is implemented thanks to RFID technology. Because there are a few types of grease-boxes with different shapes and sizes, a series of types of odometer’s interfaces in different dimensions has been designed and produced.

### 3.2. Controller with application

The odometer cooperates with a portable PDA computer with colour LCD touchscreen, resistant to outside conditions and falls. It has been equipped with GSM module, GPS, RFID reader and USB. The device is intended for staff responsible for train check in or technical inspection. Thanks to appropriate software it is possible to make a fast wireless data reading about next wagons of the train (id numbers of a wagon, length, mass, brake settings, mileage, bearing temperature, etc.) and to update current data (load’s mass, type of load, person responsible for check in, remarks about technical shape of the wagon). The device is equipped with GPS, which causes that read data are always provided



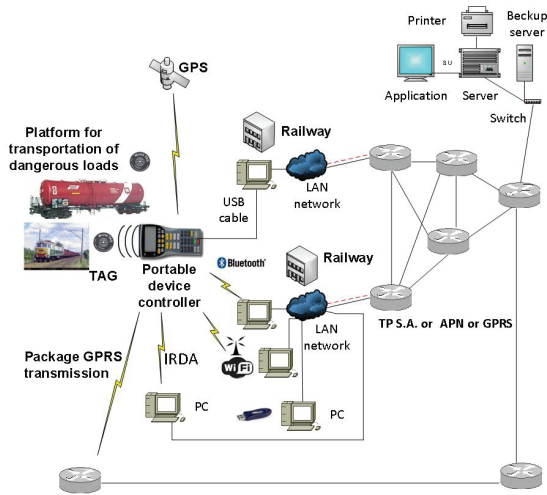

Fig.4. Structure of telemetric system

Source: [12]

with accurate position of every wagon during check in. After reading of every wagon and railway-engine (railway-engines are equipped only with storage medium – TAG RFID, without sensors) the complete report is sent to database (GPRS transmission) in the centre of data collection. That report can be shared for print as mass memory USB in a shape of filled R7 form according to PLK standard. If the existing rail structure does not enable the use of computer and printer (A4 format) in places, where check ins are done and shipping notes are prepared, there is a possibility of equipping the railway-engine with printer with the function of direct print from the controller. On the controller, based on operating system Windows Mobile 6.1, an application has been made for odometer service and reporting in the format of 17 forms. It includes such functions as: logging in, system date, settings, railway stock control system, vehicle's data, error notification, auto-diagnostics, info about engine-driver, manager, check in employee, system, list of numbers of wagons' owners, their types and types of wheelsets, setting of break strength, etc.

### 3.3 The system structure

Different versions of telemetric system were considered and a few types of medium were installed between controller and transmission system. Regarding the physical aspect, two kinds of medium have been specified – wired and wireless. In case of physical connection by wire, it is understood as a connection with cable through USB interface to work station, connected with the rest of the system with data transmission network. Wireless medium is understood as package teletransmission network GPRS and optionally also WiMax, HiperLAN [10], TPSA network, Internet network and leased connections, as well as widely used standards of

wireless communication based on infrared waves IrDa and standard 802.11 b/g, Bluetooth [11].

These standards have features which significantly differ regarding reach, emitted strength, radio frequency band (length of waves) and specification of physical and logical aspect of layered model ISO/OSI.

An important element of the whole system is information exchange from monitoring and management centre in the point of data collection. The central point of the system is electronic database and map server with Internet access (WWW). Authorized user has access to all read “on-line” data (R7 reports, location of the wagons on map, mileage and bearing temperature monitoring and submitting remarks about technical state of the wagons) as well as receives notifications (about upcoming main repairs and failures) and has access to all track and wagons history. Thanks to its functionality the system can be used as “blackbox” and have ability to register the date above. The structure of the system has been presented on Fig. 4.

### Acknowledgements

The article was written within the target project ‘Preparation and implementation of the device supporting diagnostics of rail platforms carrying dangerous materials’ cofinanced by the National Centre for Research and Development from the funds dedicated to financing science in the years of 2010-2011

## 4. Conclusion

Thanks to presented work solutions there is a possibility of wide use of telemetric system to monitor and diagnose rail vehicles. In particular, the system is appropriate for mileage monitoring of wheelsets and axles as well as bearing temperature in conditions of lack of electric power supply in case of goods wagons and cisterns. The very important aspect of the system is the possibility of using it to monitor dangerous loads (e.g. cisterns), for it also enables GPS location of such loads and can handle the function of “blackbox” with a proper failure prediction. The system can be easily calibrated and can be adjusted to the needs of different carriers as well as it can be expanded while requirements evolve. Data transmission from controllers to the system can be done with the use of all modern wired and wireless medium, depending on the wish of the client considering also cost optimization for its access. The suggested solution of independent power supply of micro-controller circuit and its wireless data transmission with the use of wireless power supply from the PDA controller also allows for using this solution in other telemetric purposes, especially in situation of lack of access to electric power sources. Currently, the prototype of the system is being prepared for “on-line” tests.

## Bibliography

- [1] The letter of UTK Director (09.10.2009) recommending inspection of rolling stock and diagnostics of axles and wheelsets.
- [2] Transport Law (Dz. U. nr 53, poz. 272).
- [3] Decree of the Minister of Transport and Marine Economy (18.03.1999) (Dz. U. nr 29, poz 278, § 2.1).
- [4] Decree of the Minister of Infrastructure (15.02.2005) regarding certificates of technical efficiency of rails vehicles § 3.
- [5] Regulations of goods wagons economy G.W.T. R-2 Polskie Koleje Państwowe, Wrocław 1993.
- [6] K. CZEPIŃSKI, Licznik kilometrów do pojazdów kolejowych, Urząd Patentowy Rzeczypospolitej Polskiej, Warszawa, 14th October 1936.
- [7] www.haslerrail.com, Hasler RT/A.
- [8] RAIL TECH PAPLA Sp. z o.o. REJESTRATOR DANYCH TELOC Hasler Rail, Bielsko Biała, August 2007.
- [9] ENTE Sp. z o.o. METRONIX – System monitorowania zużycia paliwa i wspierania procesów logistycznych przewoźnika kolejowego. Konferencja nowoczesne rozwiązania dla taboru szynowego. Radiokomunikacja Kolejowa. Gdańsk 19-20 lutego 2008.
- [10] T. HEJCZYK “Bezprzewodowe systemy transmisji pakietowej w oparciu o standard HIPERLAN 2 I Bluetooth”, VIII Konferencja Sieci Komputerowe, 18-20 czerwca 2001, Krynica.
- [11] T. HEJCZYK “Bezprzewodowe sieci LAN w oparciu o standard IEEE 802.11 I ETSI HIPERLAN”, VII Konferencja Sieci Komputerowe, 14-16 czerwca 2000, Zakopane.
- [12] Project no. 422/BO/A “Developing and implementing a device supporting diagnostics of rail platforms transporting dangerous loads”.