

**Janusz GARDULSKI**

Silesian University of Technology, Faculty of Transport,  
Department of Automotive Vehicle Construction  
Kraśińskiego St. 8, 40-019 Katowice, Poland  
*\*Corresponding author.* E-mail: janusz.gardulski@polsl.pl

**WAVELET CLASSIFIER USED FOR DIAGNOSING SHOCK ABSORBERS  
IN CARS**

**Summary.** The paper discusses some commonly used methods of hydraulic absorber testing. Disadvantages of the methods are described. A vibro-acoustic method is presented and recommended for practical use on existing test rigs. The method is based on continuous wavelet analysis combined with neural classifier and 25-neuron, one-way, three-layer back propagation network. The analysis satisfies the intended aim.

**ZASTOSOWANIE KLASYFIKATORA FALKOWEGO W DIAGNOSTYCE  
AMORTYZATORÓW SAMOCHODÓW OSOBOWYCH**

**Streszczenie.** W artykule omówiono powszechnie stosowane metody badania amortyzatorów hydraulicznych oraz wymieniono ich wady. Przedstawiono metodę wibroakustyczną, która może być zastosowana w praktyce, przy wykorzystaniu istniejących stanowisk badawczych. Metoda ta oparta jest na ciągłej analizie falkowej z wykorzystaniem klasyfikatora neuronowego z siecią jednokierunkową, trzywarstwową, o 25 neuronach, ze wsteczną propagacją błędów, która spełnia postawione jej zadania.

**1. INTRODUCTION**

Springs and damping elements contained in independent suspensions of modern cars have non-linear characteristics. In medium or lower class cars the springs are usually steel spiral springs because of their simple design, easy shaping, small size and low price. Their non-linear stiffness characteristics are usually strongly related to a change in spring lead or outer diameter, or a change in wire diameter. A diagnosis on springs is an easy task. In most cases organoleptic tests, sometimes supported by dynamometric tests, are quite sufficient.

Vibrations in cars are damped by means of telescopic fluid absorbers having non-symmetric (usually progressive or progressive-degressive) characteristics. Apart from absorbers, there are tyres, springs, ball-and-socket joints and metal-rubber sleeves to play a role in damping vibrations. But the role of absorbers is often decisive. Defective absorbers may cause excessive acceleration amplitudes in car body vibration, excessive car rolls, both lateral and longitudinal (important for comfortable travel and car travel stability), poor contact between car wheels and the ground both during travel and braking, excessive braking distance. Excessive dynamic forces will result in fatigue destruction of car components and road surfaces.

## 2. METHODS OF TESTING THE ABSORBERS

Diagnostic tests on fluid absorbers are difficult. Usability i.e. damping capacity of such absorbers are only assessed with kinematic extortion stimulating vibration in sprung and unsprung masses of the car between springs and damping elements. Testing methods to be used for absorbers must satisfy the following technical and economic requirements:

- no need to remove the absorbers from the car for testing,
- short time of measurement.

Among methods requiring no removal of the absorbers, Eusama and Boge types (or their derivatives) are most popular, and both involve forced vibration. The methods are based on harmonic, mechanical vertical vibration inductors which stimulate vibration in the car wheel which has been placed on the test rig plate. Stimulation period has three phases. Full testing cycle takes approx.40 sec. and has three phases. As soon as the inductor is switched on, the plate will run up to receive over-resonance suspension frequency in approx.1/4 of the cycle. Phase 2 imposes extortion with stable frequency as before (approx 1/2 of the cycle). When the inductor is switched off (phase 3) the vibrations disappear in about 10 sec. This is a free vibration period with resonance in sprung and unsprung masses. The technical state of the absorber is indicated by the amplitude that can be seen with suspension resonance frequency. Damping efficiency is defined on the basis of vibration analysis:

- in function of time (Boge method),
- in function of wheel pressure on the plate (EUSAMA method).

Boge method assumes that absorber quality indicator is damping decrement considered as double amplitude of resonance vibrations (Fig.1). Course of vibrations in the plate is recorded (usually by means of an ultrasonic probe) and compared with reference courses of absorbers in the car model. This enables to assess the absorber quality in percentage terms. Main shortcoming of the method is great simplification, assumption regarding linear characteristics of damping process and necessity of having previous records to refer to.

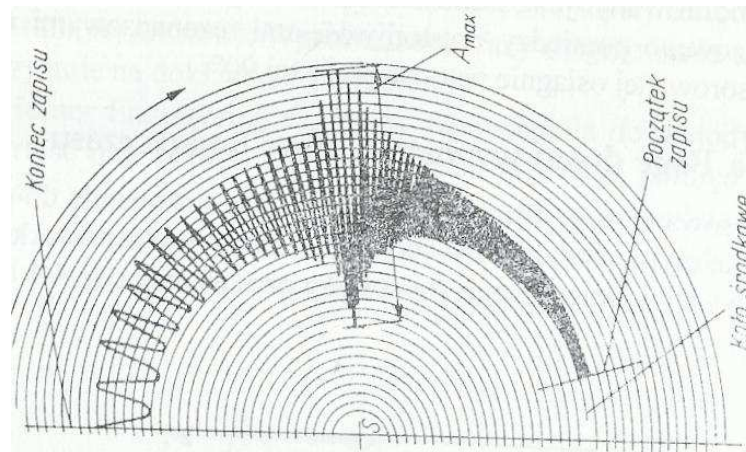

Fig. 1. An example of results if Boge device was used for testing absorbers  
Rys. 1. Przykładowy wynik badań amortyzatorów na urządzeniu Boge

EUSAMA method, developed by The European Association of Shock Absorber Manufacturers, attempts to assess adhesive force of the wheel on the plate. Damping effectiveness is shown by WE in % i.e. the ratio of minimal dynamic adhesive force of the wheel on the plate to static adhesive force. Static force is determined with inductor standstill whereas dynamic force-with stable frequency 16 Hz corresponding approximately to unsprung mass resonance frequency (Fig. 2).

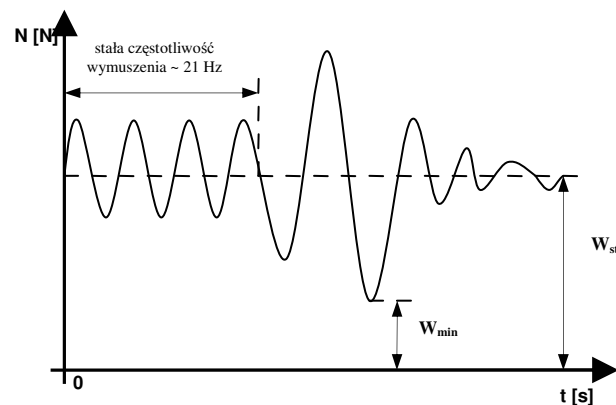

Fig. 2. Graphic interpretation of EUSAMA ratio

Rys. 2. Graficzna interpretacja współczynnika EUSAMA

Advantages of the method are that test rig standard can be established and a large statistical material. A disadvantage (like in previous method) is (1) that a linear characteristics of damping was assumed and (2) practically two-state school-like system of assessment as below:

- a) WE = 0-20% - bad technical state of shock absorbers (insufficient damping rate),
- b) WE = 21-40% - acceptable damping rate - testing (upon removal) on indicator test rig required,
- c) WE = 41-60% - good damping rate,
- d) WE > 60% - very good damping rate.

Both methods of testing absorbers have an important diagnostic fault, namely they do not identify the type of damage to the absorber. The fault is not evident with vibro-acoustic methods of testing shock absorbers mounted in cars.

### 3. VIBRO-ACOUSTIC METHODS OF DIAGNOSING SHOCK ABSORBERS

When performing vibro-acoustic tests on shock absorbers mounted in cars, kinematic extortion will be stimulated by means of existing vibration inductors as above. The car can be considered as vibrating, non-linear, non-stationary material system with short-term extortion. When testing signals emitted by such systems, the following multidimensional methods of analysing non-stationary random signals (showing spatial pictures of spectral changes in time function) can be used:

- short-term Fourier transform,
- Wagner-Ville transform,
- continuous wavelet analysis transform.

From a practical point of view, continuous wavelet analysis is most suitable for diagnosing shock absorbers mounted in cars.

Wavelet analysis allows to use windows which automatically get reduced with high frequency analysis and expands when low frequency analysis is performed. This enables correct analysis with both low and high frequency. Both wavelets and their spectra can be fast-fading functions and therefore they are suitable windows for integral transformations. Wavelet transformation results in time distribution of wavelet coefficients WT for the scale which is strongly related to frequency. Continuous wavelet transformation will convert time signal into distribution by scale-time system within the selected range. On admitting wavelet frequency properties, the result can be shown by time-frequency system. The presentation of results in wavelet transformation enables easy interpretation of the results, particularly their frequency properties.

Based on such assumptions, vibro-acoustic method will use existing vibration inductors. Just like in cases such as the methods described previously, the car (or rather the wheel of the suspension unit) is placed on the inductor plate.

Measurements are performed upon switching off its power transmission system. Measured values are differences in acceleration between absorber piston and absorber sleeve, their technical state being fully identified. Converters were mounted on points A and B as shown in Fig. 3.

Identification was performed on indicator test rig, and the absorbers had programmed defects connected typically with wear and tear, namely:

- 1) absorber fluid leakage,
- 2) piston seal loss.

a)

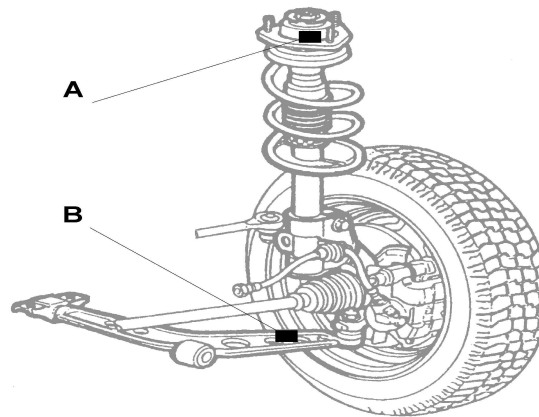

b)

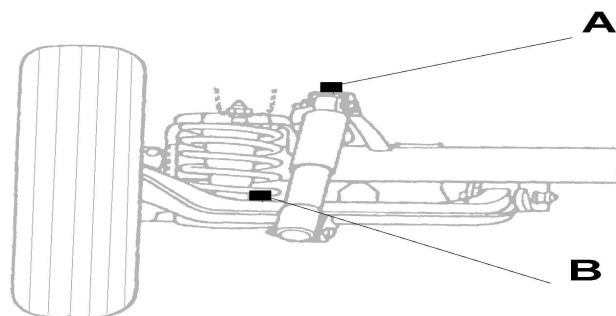

Fig. 3. Points where detecting elements are mounted: a) in the front suspension, b) in the rear suspension (Fiat Seicento)

Rys. 3. Punkty mocowania czujników pomiarowych: a) w zawieszeniu przednim, b) w zawieszeniu tylnym (Fiat Seicento)

Analog Devices converters ADXL105 and ADXL250 together with measuring module HAD-1200 were used for the measurements. The latter is a 16-bit card for PC computers, equipped with 12-bit A/C converter and analog multiplexor enabling measurements with max. 8 channels (differential mode) or 16 channels (common mass). The measuring module was operated by factory software enabling preview of the measured values and their savings within real time. The measuring procedure consisted of recording the signal of body vibration accelerations with sampling frequency 500 Hz. Database was established in computer mass storage in the form of time courses for vibration accelerations. Analyses of the results were performed using engineer calculation environment MATLAB.

Wear and tear was simulated as follows:

- 1) leakages - through reducing amounts of fluid in absorbers by 5% from 100% to 50% of nominal volume, where 100% corresponded to full, leak-free (new) absorbers,

2) wear of piston seal - through 2%, 4% and 6% circumferential loss in piston seal.

Recorded signals of vibration accelerations were sampled to frequency 2 Hz using stuck functions. Suspension resonance frequency band was analyzed within the scale 80-200, step every 10, using Morlet wavelet with frequency band width  $B_0 = \omega_{\max} - \omega_{\min}$  1.701 Hz and mid-frequency  $\omega_0 = 2\pi f_0 = 5(\text{rad/s})$ . Body resonance frequencies were tested for the scale range 100-300, step every 8, using simlet wavelet with frequency sampling 0.5 kHz (wavelet sim.8, band  $B_0 = 3.14$  Hz, frequency  $\omega_0 = \pi(\text{rad/s})$ ). Such procedure was obligatory for analysis of vibration accelerations both in front and rear parts of the car body as received on the test rig with harmonic extortion.

#### 4. ACCEPTED DIAGNOSTIC ESTIMATORS

According to the assumed aim of the study, an attempt was made to find suitable estimators enabling clear identification of the type of damage. Analysis of well-known and commonly used estimators did not give satisfactory results. Therefore careful consideration was given to personal, new estimators of point, linear or higher grade types. In result, quite new estimators were determined. They can be used in diagnostics of shock absorbers. The most suitable features of diagnostic parameters are found in the coefficients  $WT_{zaw}$  and  $WT_{nad}$  determined respectively for resonance frequencies in sprung masses and unsprung masses. Value of  $WT_{zaw}$  estimator in case of suspension resonance frequency was defined as follows:

$$WT_{zaw} = \frac{|WT_{\max}| + |WT_{\min}|}{2} \quad (1)$$

where:  $WT_{\max}$  = maximal value of WT in resonance zone,  $WT_{\min}$  = minimal value of WT in resonance zone.

Maximal values of  $WT_{zaw}$  coefficient occur for new dampers, and they decrease as the piston seal becomes defective. Dynamics of these changes remains the same for all tested states of absorber filling. Furthermore, the coefficient decreases in value as the leakage becomes larger with specific loss in the piston seal.

When performing resonance frequency analysis of the car body, the same  $WT_{nad}$  estimator was used as follows:

$$WT_{nad} = \frac{|WT_{\max}| + |WT_{\min}|}{2} \quad (2)$$

where:  $WT_{\max}$  = maximal value of WT in resonance zone,  $WT_{\min}$  = minimal value of WT in resonance zone.

Analysis of the above coefficient value in the body resonance frequency band allows us to claim that as technical state of the absorber deteriorates, an observable increase in  $WT_{nad}$  can be noted when extortion of the test rig is in operation and shortly after its shut-down. A decrease in  $WT_{nad}$  value occurs when vibration frequency decreases (the system passing through resonance frequency of the car body).

Sum of wavelet coefficients  $\Sigma WT$  was accepted as a diagnostic estimator as follows:

$$\Sigma WT = WT_{nad} + WT_{zaw} \quad (3)$$

A cumulative diagram showing estimator distribution in function of fluid and piston seal losses is presented in Fig. 4.

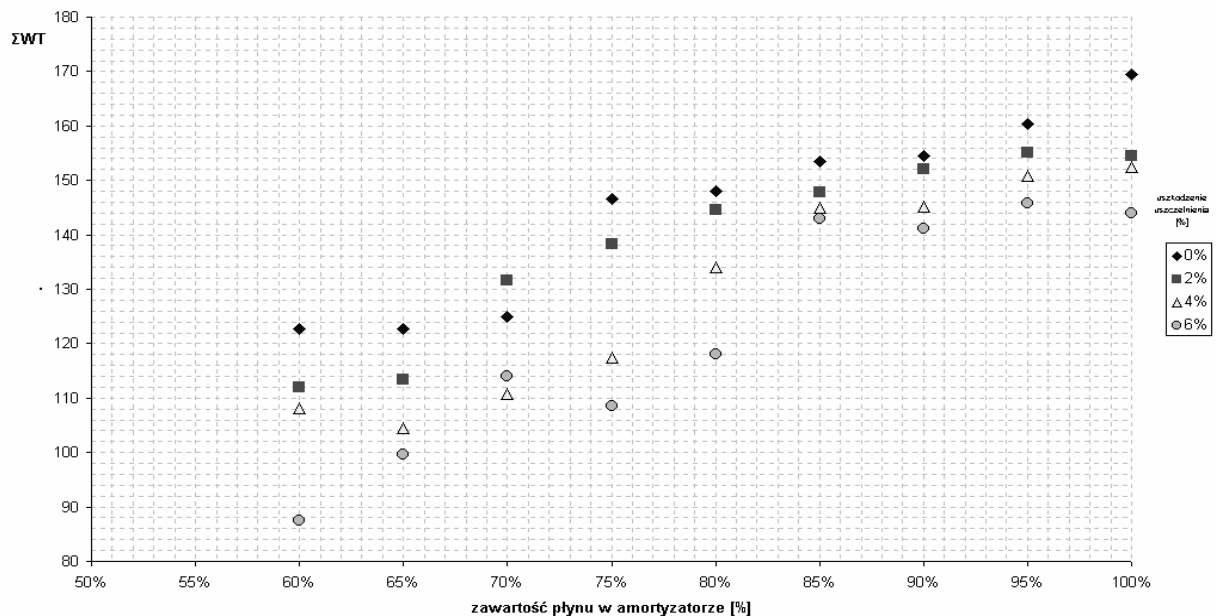

Fig. 4.  $\Sigma$ WT values for resonance frequencies of sprung and unsprung masses in Seicento car front suspension  
Rys. 4. Wartości  $\Sigma$ WT dla częstotliwości rezonansowych mas resorowanej i nieresorowanej przedniego zawieszenia samochodu marki Seicento

The coefficient is highly sensitive to changes in shock absorber technical state.  $\Sigma$ WT values goes down as technical state of the front absorber deteriorates. The situation is clear if single damages occur. Changes in the coefficient value enable identification of the absorber defect. If two or more damages occur, the coefficient enables recognition of „the worst” defect.

## 5. CLASSIFYING SHOCK ABSORBER DEFECTS BY MEANS OF WAVELET CLASSIFIER

Diagnosing process requires an answer to questions regarding relationship between features and parameters of the absorber state should be given as quickly as possible.

Therefore the diagnostic process must employ automatic methods of classification independent of the operator. Classification is a form of conclusion-making that assigns an object having unknown technical state to a specific single class.

On the basis of neural network theory, it was proposed that an appropriate classifier for diagnosing shock absorbers should employ the above-mentioned estimators determined through wavelet analysis of relative accelerations in vibration of sprung and unsprung elements. Using neural network output signals, tested absorbers were classified as follows:

- a) in respect of absorber fluid leakage:
  - class 1 - 100%, 90% of the fluid volume,
  - class 2 - 90%, 80% of the fluid volume,
  - class 3 - 80%, 70% of the fluid volume,
  - class 4 -  $\leq 70\%$  of the fluid volume,
- b) in respect of piston seal defect:
  - class 1 – no loss of the seal,
  - class 2 – defect in the seal.

Such classification allows to recognize 8 different technical states of absorbers.

We used artificial neural network theory and Matlab Neural Network Toolbox, and we decided to choose feed-forward back propagation network. The following parameters were identified:

1) Neural classifier structure:

- three-layer network with bias, input layer consisting of 4 neurons and hidden layer consisting of 6 neurons; structure of the network is shown in Fig. 5.

2) Neural activation functions:

- for the first layer: unipolar continuous function (logsig),  
- for the hidden layer: bipolar continuous function (tansig),  
- for the output layer: linear function (purelin).

3) Lavenberg-Marquardt's algorithm was used in training process.

Method of training with a teacher consists of giving signals on the network input and given expected answers. Training data in the network consisted of 56 4-component vectors of the identified absorber technical states and 56 6-component vectors of the values expected on the network output. Training error threshold was assumed to be 0.01%. Training process ended successfully after 310 epochs. Course of the process is shown in Fig. 6.

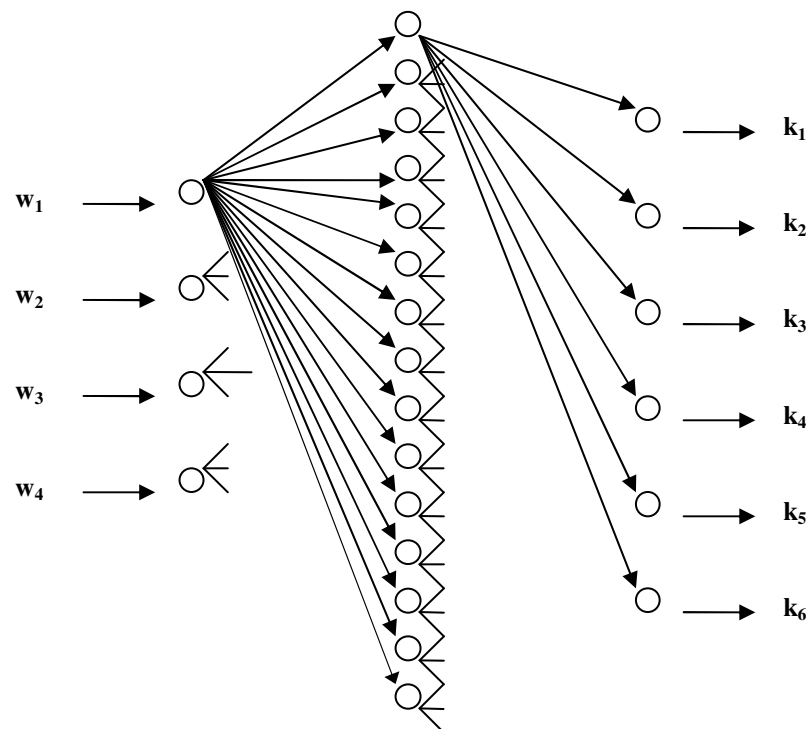

Fig. 5. Structure of the neural network

Rys. 5. Struktura zastosowanej sieci neuronowej

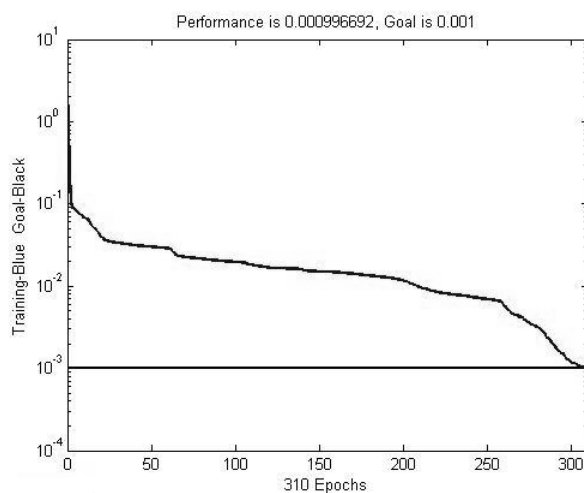

Fig. 6. Course of the network training process (training error) up to 310 epochs, end of training  
 Rys. 6. Przebieg procesu nauczania sieci (błędu nauczania) do 310 epok, zakończenie nauczania

Correct performance of neural „wavelet” classifier was verified by testing data of the absorbers with a known technical state which were not included in the training process. Verification data comprised of technical state vectors of 16 absorbers not included in the neural network training. The network correctly recognized defects in 9 absorbers and piston defects in 6. One absorber was identified wrongly.

## 6. CONCLUSIONS

Neural classifier with 25-neuron, one-way, three-layer back propagation network, combined with signal wavelet analysis of relative accelerations in vibration of sprung and unsprung elements can safely be used for diagnosing shock absorbers mounted in cars.

Estimators developed for the network have sufficient diagnostic power. Correct results of generalized network knowledge are obtained by using a large number of training patterns. The „wavelet” classifier presented above works relatively well, and its efficiency will increase as the number of training patterns grows. Therefore a high amount of testing material is necessary.

The network training method proposed in the paper, based on four-component technical state vectors, is a satisfactory solution. It enables diagnosing 8 different technical states of a shock absorber.

## Literature

1. Batko W., Krzyworzeka P.: *A Wavelet Analysis Approach to Runout Elimination in Bearings Monitoring*. Proc. 6ICSV, Copenhagen 1999.
2. Batko W., Ziółko M.: *Zastosowanie teorii falek w diagnostyce technicznej*. Wydawnictwo WIMiR, Kraków 2002.
3. Białasiewicz J.: *Falki i aproksymacje*. WNT, Warszawa 2000.
4. Burdzik R.: *Automatyczne diagnozowanie stanu technicznego amortyzatorów zabudowanych w samochodach osobowych*. Praca doktorska (promotor J. Gardulski), Katowice 2006.
5. Burdzik R., Gardulski J., Konieczny Ł.: *Wykorzystanie STFT w identyfikacji stanu technicznego amortyzatorów badanych metodą drgań swobodnych*. Zeszyty Naukowe Politechniki Śląskiej s. Transport, z. 57, Gliwice 2005.
6. Gardulski J.: *Bezstanowiskowa metoda oceny stanu technicznego zawiesznień samochodów osobowych*, Warszawa-Radom 2003.



7. Gardulski J., Warczek J.: *Względne przyspieszenia drgań jako podstawa diagnostyki elementów zawieszonych pojazdów samochodowych*. V Krajowa Konferencja Diagnostyka Techniczna Urządzeń i Systemów, Ustroń 2003.
8. Radkowski S.: *Wibroakustyczna diagnostyka uszkodzeń niskoenergetycznych*. Warszawa-Radom 2002.
9. Reipell J., Betzler J.: *Podwozia samochodów – podstawy konstrukcji*. WKiŁ, Warszawa 2001.

Received 3.11.2007; accepted in revised form 23.11.2007