

Jan TARGOSZ*

AGH University of Technology, Robotic and Mechatronics Department
Al. Mickiewicza St. 30, 30-059 Kraków, Poland

*Corresponding author. E-mail: jantargosz@interia.pl

VIBROISOLATION OF RAILWAY TRANSPORTATION AND ENERGETIC DISTRIBUTION OF DYNAMIC INFLUENCE ON THE SURROUNDING

Summary. This research presents the concept of vibroisolation of railroad lines by example of one of the solutions designed by the author, and contains comparison of distribution of energy carried out to the subgrade of traditional and vibroisolated railroad tracks.

WIBROIZOLACJA DRÓG KOLEJOWYCH ORAZ ROZKŁAD ENERGETYCZNY ODDZIAŁYWAŃ DYNAMICZNYCH NA ŚRODOWISKO

Streszczenie. W pracy przedstawiono koncepcję wibroizolacji przejazdu kolejowo-drogowego, rozwiązania wibroizolowanego przejazdu i jego wpływ na oddziaływania dynamiczne na otoczenie na podstawie rozkładu energetycznego.

1. INTRODUCTION

Present-day constructions of railway crossing as one-level intersection of rail transportation (railway, tramway) and automobile transportation do not meet the current requirements of modern-day transportation in terms of necessary speed limits imposed on both types of transportation, dynamic influence on the environment (noise, vibrations), which comes from railway and automobile vehicles, concrete slabs' "keyboarding" and resulting in technical degradation of a crossing based on shift of slabs positioning and change of slabs' fulcrum points. It is accompanied by transmission of vibrations and noise to neighbouring objects, often of a historic meaning, situated next to the railway transportation lines e.g. tramway lines.

The construction of these crossings is specific in terms of dynamics and acoustics, the dynamic effects coming either from railway vehicles as well as automotive vehicles are transmitted entirely and directly on concrete slabs of the crossing, which affect railway-ties as well as on the ground, which is demonstrated in Fig.1.

Hence there occurred a necessity of designing the crossings construction that would enable eliminating or at least minimizing those adverse effects.

2. IDEA OF VIBROISOLATION

Based on the research carried out in Poland and abroad and on the author's own expertise in the field of vibroisolation of machines, devices and railroad subgrade for tram and railway lines (PKP

railroad station in Kraków, Zwierzyniecka S., Lubicz S.) the concept of vibroisolated railway crossing was conceived, of which scheme is demonstrated in Fig. 2. Resilient elements are introduced in railway crossing construction whose purpose is to isolate the railroad from the automobile road in order to minimize dynamic effects of vehicles passing through the crossing and to center slabs relatively to the rails.

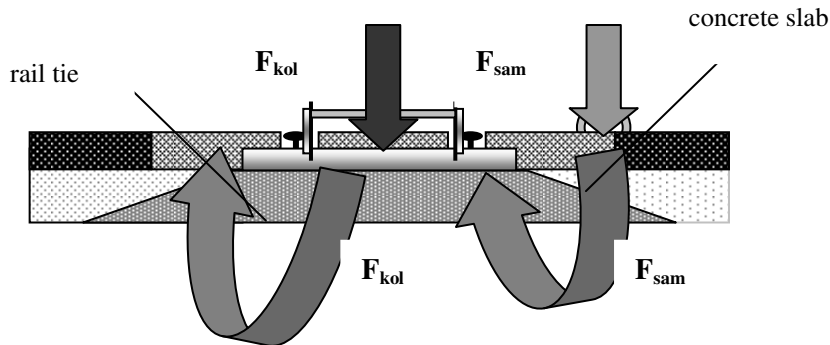

Fig. 1. Demonstration scheme of the influence of railroad and automotive vehicles on a traditional crossing
Rys. 1. Rysunek poglądowy oddziaływania pojazdów szynowych i samochodowych na tradycyjny przejazd

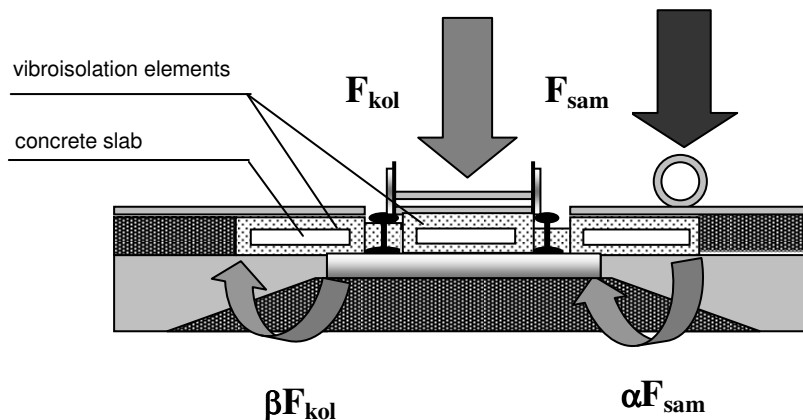

Fig. 2. Demonstration of vibroisolated railway crossing
Rys. 2. Rysunek poglądowy wibroizolowanego przejazdu kolejowo-samochodowego

The main element transmitting vibrations coming from railway transportation and automotive vehicles, presented in this solution, is a rail with a rail-tie, which owing to the application of resilient vibroisolating and sound-absorbing materials significantly lowers the dynamic and acoustical effects carried across to natural environment. It is reflected by the coefficients $\alpha < 1$ and $\beta < 1$. Comparing of the traditional and vibroisolated railway crossing can be carried out based on dynamic analysis of simplified physical models presented in Fig. 3. One of the measures of this effectiveness is the ratio of forces R_w / R_d , originated during the vehicles' passage, carried to the ground through railway crossing; without the elements of vibro- and sound isolation, and with the application of these elements.

Based on the consideration above, technical conception was developed of vibroisolated railroad crossing whose resilient and massive parameters were selected with the application of discrete-continuous model. The conception of vibroisolated railroad crossing is demonstrated in Fig. 4. The main idea of this concept involves minimizing the mutual dynamic influence of railroad line and motor vehicle road, in order to avoid the accelerated destruction of the crossing. This conception is originally developed by the author and is the subject of this publication.

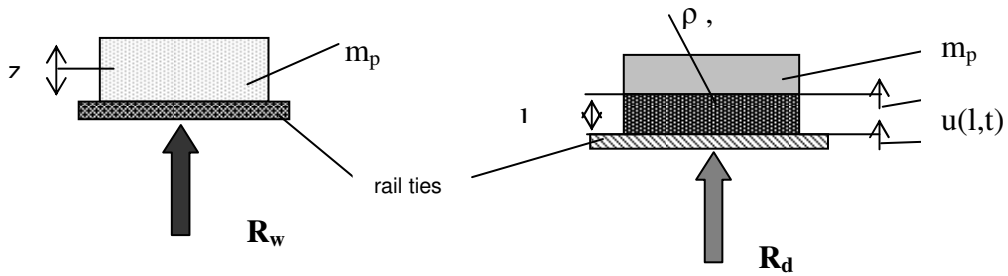

Fig. 3. Physical models of traditional and vibroisolated railway crossing
 Rys. 3. Modele fizyczne przejazdów tradycyjnego i wibroizolowanego

where: m_p – concrete slab mass + vehicle mass, ρ – rubber plate density, E^* – dynamic Young module, F – area of rubber plate, l – rubber plate thickness, $u(x,t)$ – distortion of rubber plate; $x=(0 \text{ or } l)$

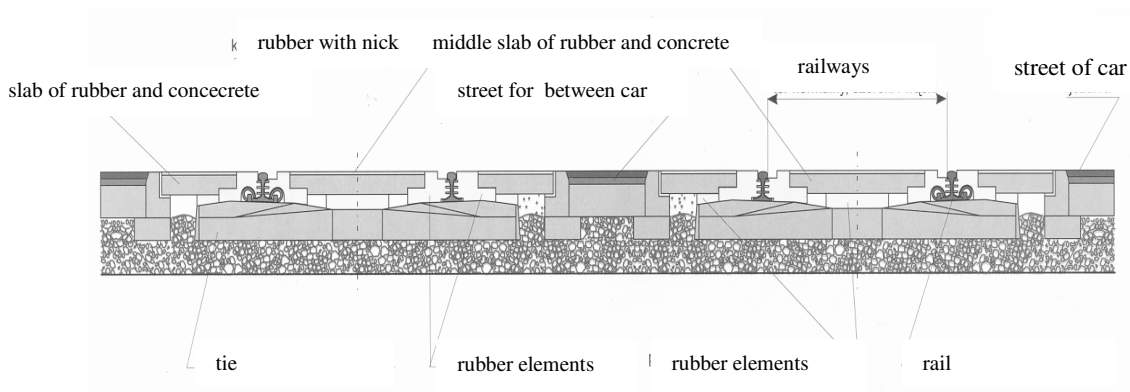

Fig. 4. Technical conception of vibroisolated railway crossing
 Rys. 4. Koncepcja techniczna wibroizolowanego przejazdu kolejowego

Of course in terms of conditions specified on the stages designing and manufacturing of railway crossings and railway-bed it should be stated that the selection of the construction architecture mostly depends on the type of the subgrade applied, on whether modernization only or overhaul is carried out. For each of this situation as well as for each subgrade type a design must be made, in which the architecture is considered individually. For example, for the same subgrade type, sound-isolating and vibroisolating elements can be applied:

- with prefabricated concrete slab covered in elastomer anti-slide layer, Fig.5

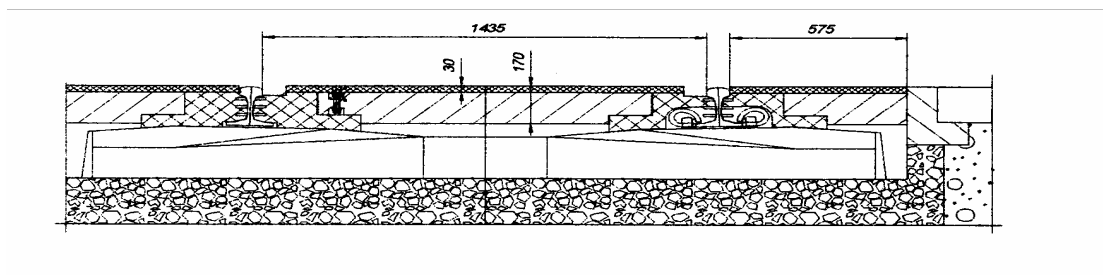

Fig. 5. Prefabricated concrete slab covered in elastomer anti-slide layer
 Rys. 5. Prefabrykowana płyta betonowa pokryta przeciwpoślizgową warstwą elastomerową

- with prefabricated concrete slab without anti-slide elastomer layer, Fig. 6

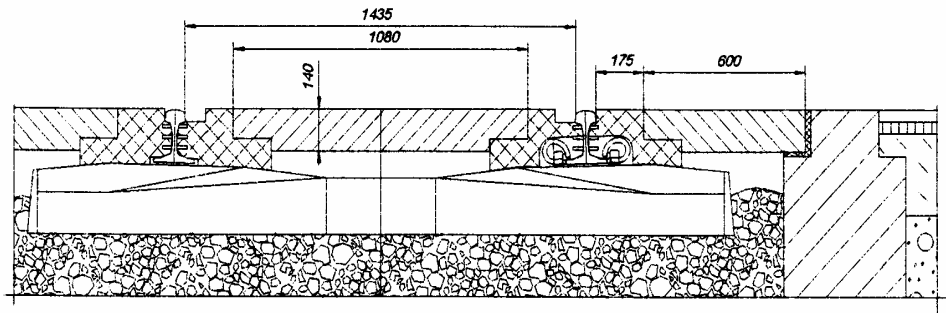

Fig. 6. Prefabricated concrete slab without elastomer anti-slide layer
Rys. 6. Prefabrykowana płyta betonowa bez warstwy przeciwpślizgowej

- with a formed elastomer plate, Fig.7.

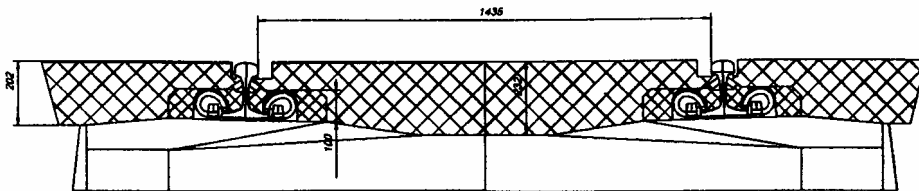

Fig. 7. Formed elastomer plate
Rys. 7. Formowana płyta wykonana z elastomeru

It is hereby tempting to make an attempt towards approximated evaluation of energy dispersion in railway crossings, i.e. to draw up an energetic balance of energy distribution based on empirical research. The attempt of such an approximated evaluation is the topic of this section. The characteristic property of the constructional solution of the railway crossing is that it contains elastic elements whose purpose is to isolate the railroad from the motorways and thereby to reduce dynamic influence of vehicles coming over the railroad crossing and to center the slabs in relation to the rails.

Fig. 8 presents the picture of such a crossing. In this solution, the main element transmitting vibrations coming from railway transportation and automotive vehicles is a rail with a rail-tie, which as a result of the application of resilient vibroisolating and sound-absorbing materials significantly lowers the dynamic and acoustical effects carried across to the natural environment.

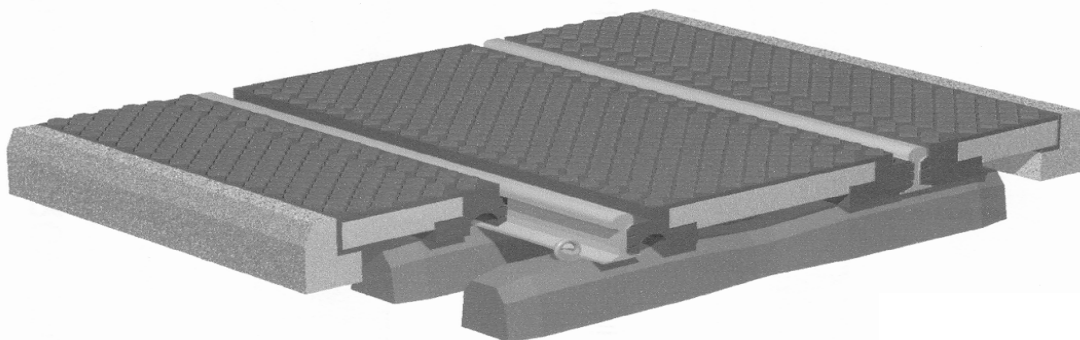

Fig. 8. Prototype of vibroisolated railroad crossing
Rys. 8. Prototyp wibroizolowanego przejazdu kolejowego

The starting point for the assessment of energy dispersion in thus designed, railway crossing is evaluating kinetic energy passing from a motor vehicle into our mechanical system. In order to preserve the possibility of determining the value of kinetic energy passed into the crossing, independently of the type of mechanical vehicle, the statically determined relation has been applied of so-called load coefficient which is calculated by the formula:

$$n = 1 + \frac{F_{z \text{ dyn max}}}{F_{z \text{ stat}}} \quad (1)$$

where: $F_{z \text{ dyn max}}$ – maximum dynamic force carried across to the ground, $F_{z \text{ stat}}$ – static ground loading. Value of n coefficient is derived form table 1.

Table 1

Relation of road loading and vehicle velocity in a straight-line motion

Surface condition	Percentage of exploitation time ^{*)}	Quantity	Car	Station wagoni	Bus	Truck	Off-road truck
Good	50	V [km/h]	90	90	80	80	60
		n	1	1	1	1	1
Bad	48	V [km/h]	70	70	60	60	40
		n	1,3	1,5	1,3	1,5	1,5 – 1,7

^{*)} The part complementing this time to 100% is associated with curved line-motion not being considered

Applying the second Newton's law we can put this formula in the form:

$$F_{z \text{ dyn}} = m\ddot{z} \quad (2)$$

$$F_{z \text{ stat}} = mg$$

Using (2.1) and (2.2) we yield:

$$\ddot{z} = g(n - 1) \quad (3)$$

which after integrating within the limits for $t = 0, z_0 = 0, \dot{z}_0 = V_0$ takes the form:

$$V = V_0 + g(n - 1)t \quad (4)$$

after substituting (2.4) into the formula we yield:

$$E_k = \frac{1}{2} m [V_0 + g(n - 1)t]^2 \quad (5)$$

The amount of energy transferred to vibroisolated railway crossing is divided into the energy carried across into the environment E_p , energy dispersed by vibroisolated material E_r , thermal energy E_c , acoustic energy E_A and residual energy E_{reszt} which includes, among other ones, the energy associated with magnetic field

The acoustic energy is given by the relation:

$$E_A = E_{ca} + E_{str} + E_{pu} \quad (6)$$

Given that the energy of the acceleration noise equals:

$$E_{ca} = \rho_0 L^3 \left[\frac{\partial u(l, t)}{\partial t} \right]^2 \left(\frac{L}{ct_0} \right)^5 \quad (7)$$

The energy of material vibrations yields: (8)

$$E_{\text{str}} = \rho_m F d 2\pi f \int_0^{\infty} \left\langle \left[\frac{\partial u(l,t)}{\partial t} \right]^2 \right\rangle dt \quad (9)$$

Vibration energy of post-impact noise is: (10)

$$E_{\text{pu}} = \sigma_{pu} \rho_0 c F \int_0^{\infty} \left\langle \left[\frac{\partial u(l,t)}{\partial t} \right]^2 \right\rangle dt \quad (11)$$

Therefore the total vibroacoustical energy yields:

$$E_A = \rho_0 L^3 \left[\frac{\partial u(l,t)}{\partial t} \right]^2 \left(\frac{L}{ct_0} \right)^5 + (\sigma_{pu} \rho_0 c F + \rho_m F d 2\pi f) \int_0^{\infty} \left\langle \left[\frac{\partial u(l,t)}{\partial t} \right]^2 \right\rangle dt \quad (12)$$

Thermal energy produced during the work of vibroisolating element is determined by relation:

$$E_c = \frac{\alpha_T^2 E_T T}{\rho C_p} \frac{\omega \tau_s}{1 + \omega^2 \tau_s^2}, \tau_s = \left(\frac{d}{\pi} \right)^2 \frac{\rho C_p}{k} \quad (13)$$

And the energy given off to the surrounding through vibroisolating element yields:

$$E_p = E_s + E_t \quad (14)$$

$$E_s = \frac{1}{2} EF \int_0^l \left[\frac{\partial u(x,t)}{\partial x} \right]^2 dx, E_t = \frac{1}{2} \mu \int \left[\frac{\partial^2 u(x,t)}{\partial x \partial t} \right]^2 dx \quad (15)$$

$$E_p = \frac{1}{2} EF \int_0^l \left[\frac{\partial u(x,t)}{\partial x} \right]^2 dx + \frac{1}{2} \mu \int \left[\frac{\partial^2 u(x,t)}{\partial x \partial t} \right]^2 dx \quad (16)$$

Of course, determining values of individual energies based on the relations presented above is very rough and their conformity can be stated no sooner than after performing long and expensive experimental research. Yet, assuming that the total energy transferred to vibroisolated railway crossing is kinetic energy coming from motor vehicle, we can execute a decent energetic balance adapting, these quotients as measure of energy distribution:

$$v_i = \frac{E_i}{E_k} 100\% \quad (17)$$

where: E_i – individual determined energies, E_k – kinetic energy.

Based on the relations allowing determining partial energies approximately, diagram of energetic balance can be drawn up as demonstrated for vibroisolated system in Fig.9.

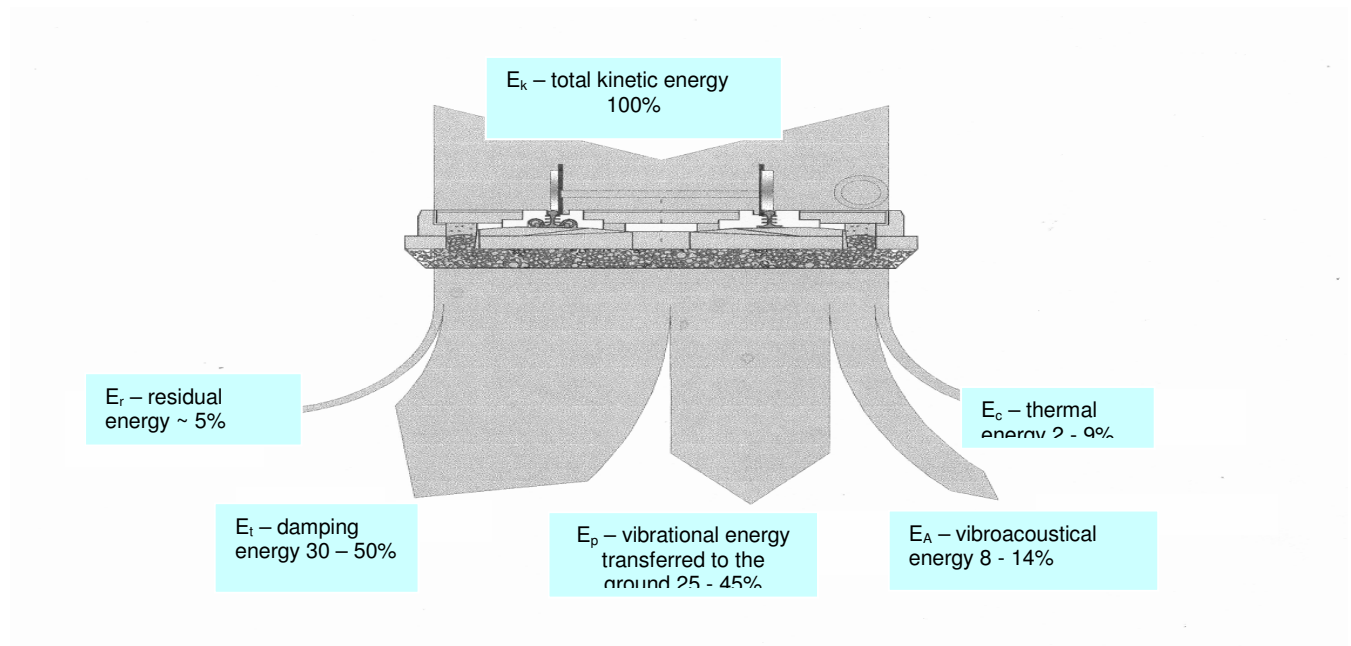

Fig. 9. Energetic balance of vibroisolated railway crossing

Rys. 9. Bilans energetyczny wibroizolowanego przejazdu kolejowego

In case of traditional railway crossing (without vibroisolation) the probable energetic balance is demonstrated in Fig. 10, i.e. damping energy would be included in the energy carried across to the ground. Probably also vibroacoustical energy would increase, especially post-impact noise and acceleration noise energy levels would go up, which would bring in effect the increase of noise level in the environment surrounding intersecting railway tracks and automobile road.

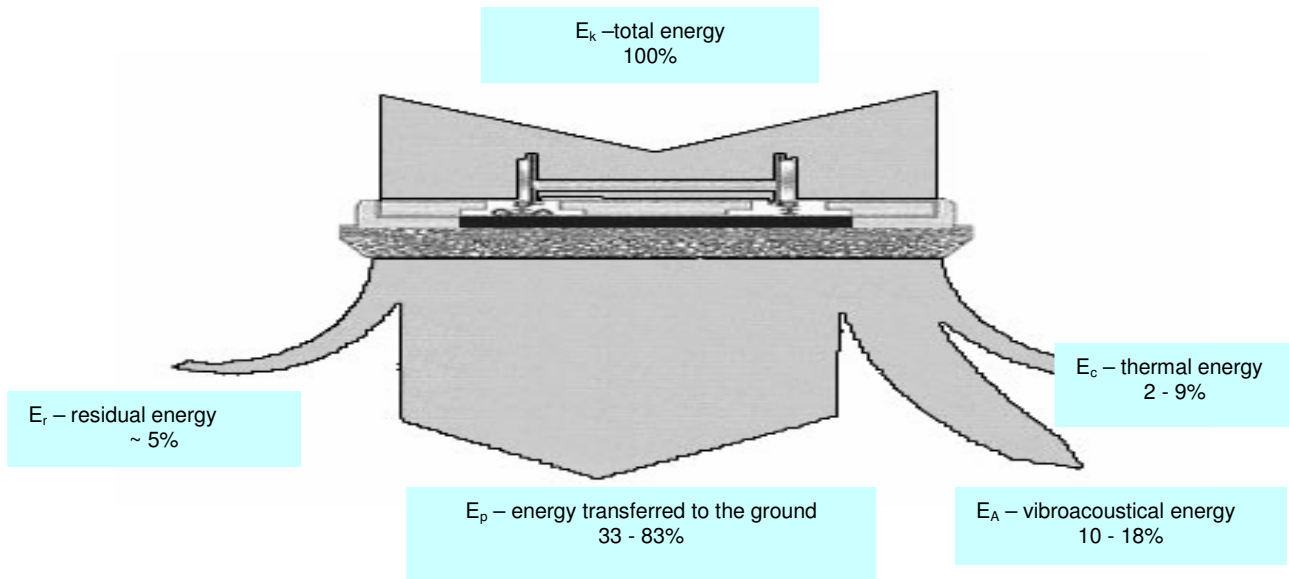

Fig. 10. Energetic balance of traditional railway crossing

Rys. 10. Bilans energetyczny tradycyjnego przejazdu kolejowego

3. CONCLUSIONS

After the analyses of a dozen or so types of railway crossings used in our country it can be stated that there was until now no ideal structure. It seems that close to ideal is the conception of railway crossing settled on a vibroisolation system. All other solutions are quite troublesome owing to the emitted noise or vibrations carried across to the surrounding during the railroad-vehicle or a motor-vehicle passage. The latter disadvantage is particularly bothersome in city areas, where there are residential buildings right in the vicinity of railroad lines. This drawback can be effectively eliminated by constructing railroad crossings mounted on a vibroisolated system. In order to construct a prototype railroad crossing, it was necessary to carry out a series of experimental research that were concerning strength properties, durability, temperature influence and vibroisolating parameters (resilience, damping) of the elements being included in the railroad crossing structure (vibroisolating elements, concrete slabs). The results of these researches enabled the choice of elastic surface elements, vibroisolating elements, inertial concrete slabs and other structural elements for vibroisolated railroad crossing. They were also the basis for carrying out the simulation of dynamics of such a crossing under different load conditions.

Fig. 8 encloses the prototype model of such a type of railroad crossing construction manufactured based on the conception demonstrated in Fig. 4. The structure of railroad crossing presented above is mounted on the additional railway ties which are not fixed to rails. The applied elements of vibroisolating protection eliminate a great deal of noise emission as well as vibration emission. Their assembly technology allows for significant expedition of maintenance work at the crossing elements replacement, since most of it is performed not on a repaired object but in a facility manufacturing vibroisolated crossings using predetermined technical guidance.

The experience associated with the exploitation of vibroisolated track beds is 18-year long, and for the time being there is no record of the track-beds being excessively worn out or defected. Vibroisolated railroad crossings are now three years old and are subject to constant inspections in terms of their durability as well as vibroisolation effectiveness.

As a result of the research carried out by the author's article some patents and usage guidance were drawn up. Many vibroisolation systems for track vehicles and automobile vehicles were implemented based on these patents: platforms 2-5 at PKP railway station in Kraków in the years 1988-1990; vibroisolation of tramway beds in Kraków (Starowiślna S., Lubicz S., Zwierzyniecka S. in the years 1993-2000) Wrocław, Bydgoszcz; six railroad crossings on one-level intersections of railroad tracks and motor-vehicle road in the years 2001 – 2003 in Poland and abroad.

Based on these, a conclusion can be drawn that the application of every other structural solution of a railroad crossing is unfavorable, especially in city agglomerations, and brings the risk of emission of excessive noise or excessive dynamic effects on the surrounding during the vehicles passage. This is best demonstrated in energetic balance of the individual types of railroad crossings in Fig. 8 and 9.

Literature

1. Adamczyk J., Stojek Z., Targosz J.: *Wibroizolacja podtorzy szynowych*. PAN – Oddział Kraków, Prace Komisji Mechaniki Stosowanej, Mechanika 15, 1991, s. 7- 24.
2. Targosz J.: *Theoretical basis of vibroisolation of the track structure*. ZN. AGH, Mechanika, t.19, z. 2, 2000, s. 255-258.
3. Targosz J.: *Ograniczenie oddziaływań dynamicznych od dróg kolejowych i samochodowych*. Monografia KRiDM AGH, Kraków 2004, s. 1-247.