

Stress Rupture Test of MAR-M509 Alloy with Structure Refined by Rapid Resolidification

M. Mróz*, W. Orłowicz, M. Tupaj, A. Trytek

Department of Casting and Welding, Technical University of Rzeszów,
ul. Wincentego Pola 2, 35-959 Rzeszów, Poland

*Corresponding author. E-mail address: mfmroz@prz.edu.pl

Received 02.07.2012; accepted in revised form 03.09.2012

Abstract

This study presents results of stress rupture test of MAR-M-509 cobalt alloy samples, as-cast and after surface refining with a concentrated stream of heat. Tests were conducted on samples of MAR-M-509 alloy castings, obtained using the lost-wax method. Casting structure refining was performed with the GTAW method in argon atmosphere, using the current $I = 200$ A and electrical arc scanning velocity $v_s = 100, 150, 200$ and 250 mm/min. The effect of rapid resolidification of the MAR-M-509 alloy on the microstructure was examined and significant improvement in stress rupture test was observed.

Keywords: MAR-M-509 alloy, Rapid resolidification, Microstructure, Stress rupture test

1. Introduction

MAR-M509 is a cobalt-bases superalloy. It displays good mechanical properties and in particular creep resistance, oxidation and corrosion resistance [1]. The MAR-M509 alloy is used to produce a segmental ring sealing the low-pressure turbine in aircraft jet engines. During changeable operational conditions, described by a complex engine loads spectrum, the ring is subject to variable fields temperature and stress fields. The load spectrum for the battlefield support aviation, fighting aviation and civil aviation aeroplanes indicated that for achieving the momentary maximum thrust, the driving assembly often reaches parameters which exceed the permissible limits [2]. Increasing thrust is accompanied by a violent increase in exhaust gas pressure and temperature; decreased thrust is accompanied by decrease of these parameters. Temperature and pressure variations as well as stress changes related to them intensify wear of the power unit elements. Thus, the importance of new material refining methods is

growing, as they will allow to improve the aircraft engine components' functional properties such as, for example, heat resistance and high temperature creep resistance.

Recently, methods which allow for surface refining of casts by remelting them superficially with concentrated stream of heat, with later rapid resolidification, have gained increasing popularity [3, 4]. Rapid resolidification of the surface layer of cobalt cast alloys enables obtaining tiny dendritic grains of γ -phase and super-fine carbide phase precipitations. Service properties of parts made from MAR-M-509 alloy are the result of the properties and morphology of all structural components occurring in the alloy [5–7]. The aim of the present study was to determine the effect of rapid resolidification on the microstructure and stress rupture test of MAR-M-509 alloy samples.

2. Material and experimental conditions

The cobalt alloy (MAR-M-509) was prepared in the Leybold Heraeus inductive vacuum furnace. The chemical composition of the MAR-M-509 cobalt alloy shown in Table 1.

Table 1.
The chemical composition of the MAR-M-509 cobalt alloy

Content of elements, wt.%											
C	Si	Ni	Cr	W	Ti	Fe	Ta	Zr	B	Co	
0.57	0.13	10.31	23.10	7.10	0.17	0.18	3.78	0.34	0.01	rest	

Casts of plates for surface fusing were of the following diameters: 110x30x5 mm. Moulds of plate casts were prepared in the lost-wax method (Fig.1).

The plate casts were fused with electric arc plasma (the GTAW method) at the stand which allows for intensified removal of heat by washing the plate bottom surface with water.

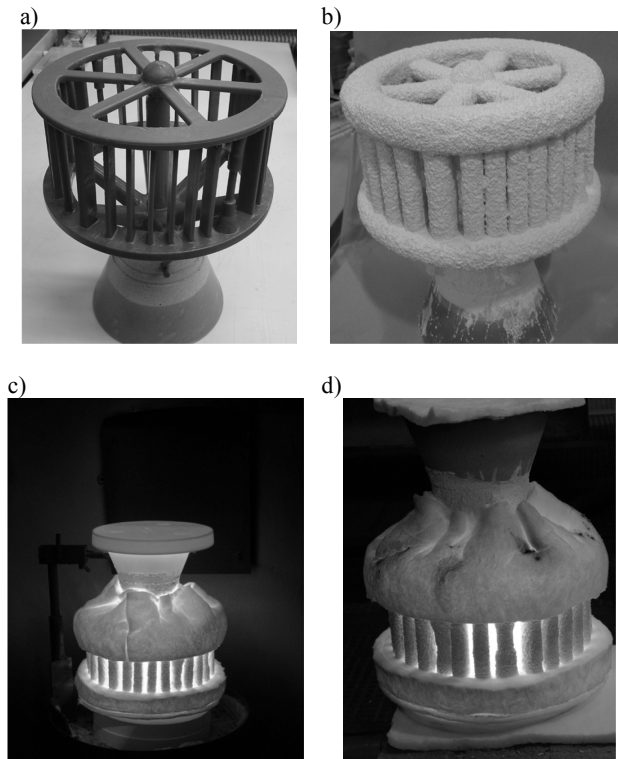

Fig. 1. Preparation of MAR-M-509 alloy plate casts; a) wax model set, b) wax model set with ceramic coating, c) mould annealing, d) ceramic mould after filling with liquid metal

The plate remelting process was conducted on both sides, with overlapping runs. The current used was $I = 200$ A, and the advance speed was $v_s = 100, 150, 200$ and 250 mm/min. Selection of these parameters of the superficial remelting process guaranteed obtaining remelting areas from 2.7 mm to 3.2 mm deep.

Microstructure of MAR-M-509 cast alloy and after surface refining is presented in Fig. 2. The samples were etched

electrolytically in a solution of 50 ml HNO_3 and 50 ml H_2O . Voltage applied was 9 V with etching time of 3 seconds.

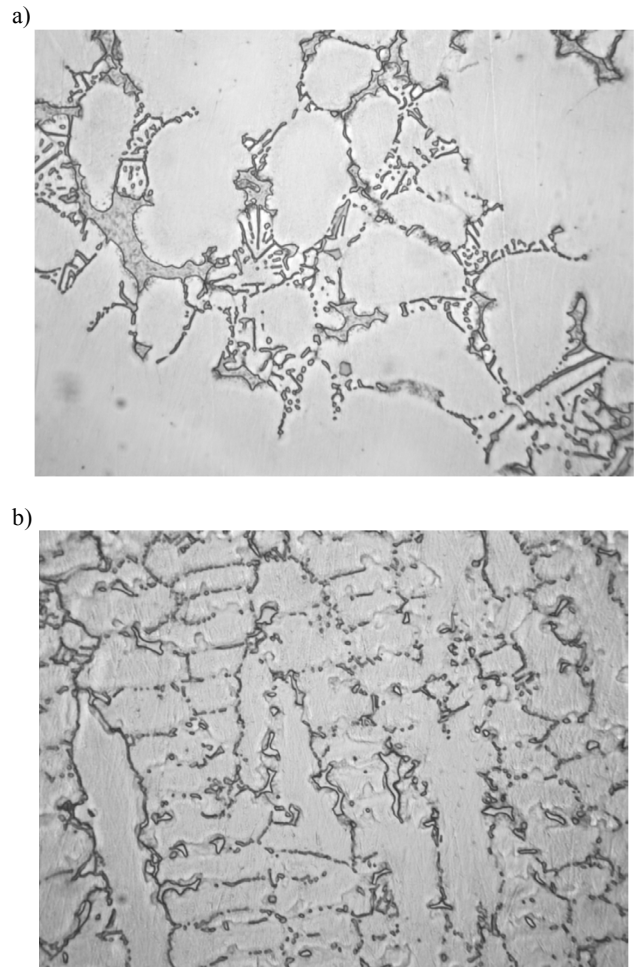

Fig. 2. Microstructure of MAR-M-509 alloy; a) as-cast, b) after rapid resolidification ($I = 200$ A, $v_s = 250$ mm/min)

Shape and dimensions of the sample for the stress rupture test are presented in Fig. 3.

The stress rupture test was performed at the stand presented in Fig. 4. Stress value was 62 MPa. The study was conducted at temperature 1093 ± 3 °C.

The results of MAR-M-509 alloy samples stress rupture test are presented in Table 2 and Fig. 5.

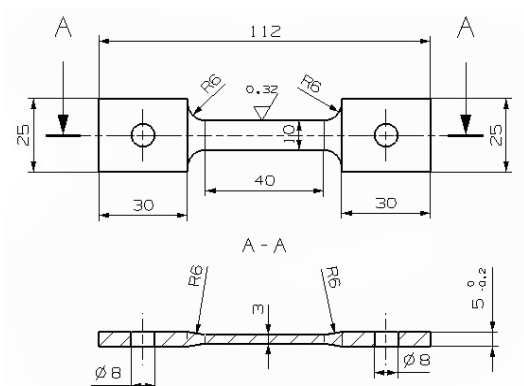

Fig. 3. Shape and dimensions of the stress rupture test sample

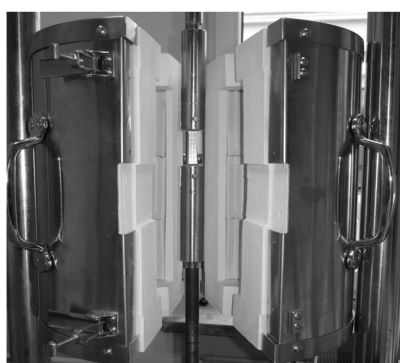

Fig. 4. Stress rupture test stand

Table 2.
Time to rupture of MAR-M-509 alloy samples

Variant	MAR-M-509 alloy	Time to rupture of samples, h
-	as-cast	29
1	after rapid resolidification ($v_s = 100$ mm/min, $I = 200$ A)	40
2	after rapid resolidification ($v_s = 150$ mm/min, $I = 200$ A)	41
3	after rapid resolidification ($v_s = 200$ mm/min, $I = 200$ A)	42
4	after rapid resolidification ($v_s = 250$ mm/min, $I = 200$ A)	44

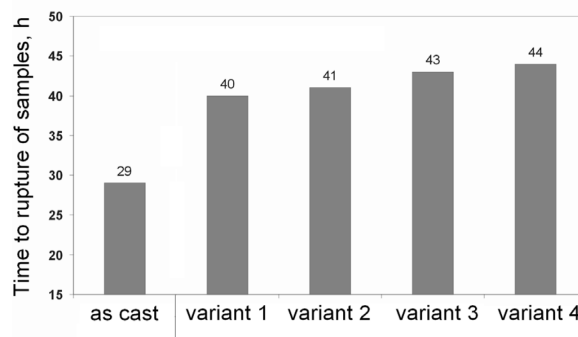

Fig. 5. Time to rupture of MAR-M-509 alloy samples

For the purpose of quantitative determination of the effect of history of the material on susceptibility to origination of cracks on metallographic sections, the number of cracks adjacent to sample edges was counted as well as the number of cracks located in the centre of thickness of the samples (Fig. 5). The measurements were carried out in the 15-mm wide strip adjacent to the fracture profile line. Such width of the measurement strip allowed to take into account all cracks observed in the analysed samples.

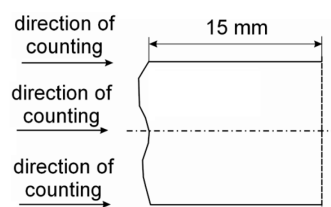

Fig. 6. Designation of the region on metallographic sections and directions for which cracks were counted

For all of the counted precipitates, their lengths were estimated. The results are presented in Table 3.

It was found that the material degradation process in the creep resistance endurance test occurred much more intensively in the case of MAR-M-509 alloy samples in as-cast condition, compared

to samples cast from MAR-M-509 alloy after rapid resolidification. This resulted in the increased time to fracture for MAR-M-509 alloy samples subject earlier to rapid resolidification.

Table 3.

The effect of the material's history on the number of cracks adjacent to the sample edge and number of cracks located in the centre of thickness of the samples

MAR-M-509 alloy	Number (length in mm) of cracks	
	adjacent to the sample edge	in the samples' thickness centre
as-cast	9 (0-0,3), 3 (0,3-0,6), 2 (0,6-0,9), 1 (1,2-1,5)	5 (0-0,3), 3 (0,6-0,9), 1 (0,9-1,2), 1 (1,2-1,5), 4 (above 1,5)
after rapid resolidification ($v_s = 250$ mm/min, $I = 200$ A)	3 (0-0,3), 1 (0,3-0,6)	not observed

An example microstructure of samples made of MAR-M-509 alloy in as-cast condition and after rapid resolidification ($v_s = 250$ mm/min, $I = 200$ A), after the stress rupture test, is presented in Figure 7.

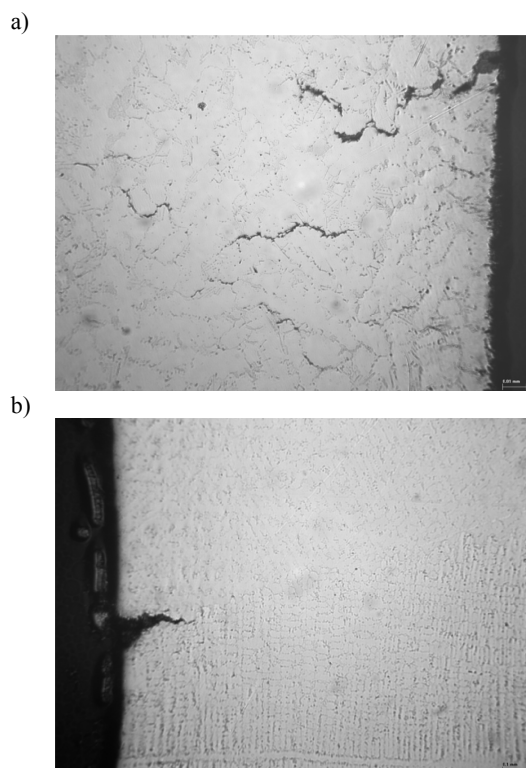

Fig. 7. Microstructure of MAR-M-509 alloy samples after stress rupture test: (a) in as-cast state, (b) after rapid resolidification ($v_s = 250$ mm/min, $I = 200$ A)

The obtained results show that in the case of samples made of MAR-M-509 alloy in as-cast condition, cracks both at surface of

the samples and in their inner regions were observed, while in the case of MAR-M-509 alloy samples after rapid resolidification, cracks located near the surface were observed. The cracks developed in direction almost perpendicular to the tensile force applied to the samples. Concentration of the cracks decreased with increasing distance from the fracture surface. Most frequently, the crack development path ran along borders of γ -phase dendrites, from one micro-crack of carbide precipitate towards another carbide precipitate containing a micro-crack.

3. Conclusions

The use of the rapid resolidification technique allows obtaining high refinement of the structural components of MAR-M-509 alloy. The effect is an increased time to rupture of the samples.

Time to rupture of MAR-M-509 alloy samples after rapid resolidification is 38-51% higher compared to the time to rupture of samples of the alloy as-cast.

Acknowledgements

Work has been performed within the project KBN No. N N508 441536, Rzeszow University of Technology

References

- [1] Klopp, W. D. (1985). *Non-Ferrous Alloys. Co. MAR-M-509. Aerospace Structural Metals Handbook.*
- [2] Rypulak, A. & Orkisz M. (2001). Widmo obciążeń turbinowych silników odrzutowych w trakcie realizacji misji lotniczych. *Journal of Koness International Combustion Engines.* Wyd. Naukowe Instytutu Lotnictwa.
- [3] Orłowicz W. & Trytek A. (2003). Effect of rapid solidification on sliding wear of iron castings. *Wear.* 254, 154-163.
- [4] Orłowicz, W. & Mróz, M. (2003). Microstructure and fatigue strength of A356 alloy casting refined on the surface by rapid crystallization. *Zeitschrift für Metallkunde.* 94, 1320-1326.
- [5] Szczotok, A., Szala, J., Cwajna, J., Hetmańczyk, M. & Skupień P. (2005). Effect of cooling speed on primary structure of MAR-M509 cobalt-base superalloy. In Proceedings of 9th European Congress for Stereology and Image Analysis and 7th STERMAT International Conference on Stereology and Image Analysis in Materials Science, Zakopane, 10-13 maj, 2005.
- [6] Szala, J., Szczok, A., Richter, J., Cwajna, J. & Maciejny A. (2006). Selection of methods for etching carbides in MAR-M509 cobalt-base superalloys and acquisition of their images. *Materials Characterization.* 56, 325-335.
- [7] Skupień, P. & Szala, J. (2008). Influence of solution heat treatment parameters on the quantity and morphology of M23C6 carbides in MAR M509 cobalt superalloy. *Inżynieria Materiałowa.* 4, 358-361.