

The Concept of Limitation of the Vibration Generated by Rail-Vehicles at Railway Stations and Railway Crossings

Jan Adamczyk*
Jan Targosz*

Received January 2011

Abstract

One of the possibilities of limitation of effects of dynamic influence of the rail-vehicles is the application of the complex objects of vibroinsulation when the mass of the vibroinsulating element is significant, and that is the case of the transporting machines and devices, when the geometric dimensions of the elements of vibroinsulation system are similar to the slab, where the process of modelling of the vibroinsulation mechanism as a discrete system, creates extreme hazards. The article presents the concept of limitation of effects of dynamic influence of the rail-vehicles and tram-vehicles, mainly in the railway tracks located at the railway stations, tram-stops and other engineering structures. The digital model was developed for simulation regarding the propagation of the vibration to the environment. The results of simulation were the basis for development of the vibroinsulation system for the rail-tracks located at the engineering structures such as railway stations, viaducts.

The second part of the article presents the approach for controlling of the tension as a function of load of the railway crossing, which was modelled as discrete-continuous model. The continuous systems consist of two elements, that is of the support made of elastomer and of the tension members with controlled tension depending on the crossing load. Together with development and more popular application of tension member systems in engineering structures, among others in vibroinsulation systems, it is important to include into calculations and experiments the dynamic loads of the tension member with the mass attached to it.

In case of complex objects of vibroinsulation when the mass of the vibroinsulator is significant, and that is the case of the transporting machines and devices, when the geometric dimensions of the elements of vibroinsulation system are similar to the slab,

* AGH University of Science and Technology, Faculty of Mechanical Engineering and Robotics
A. Mickiewicza 30 Ave., 30-059 Krakow, Poland

where the process of modelling of the vibroinsulation mechanism as a discrete system, creates extreme hazards when the vibroinsulation is chosen without consideration of its mass. The most serious of the hazards is occurrence of the wave effect of the spring-dumper elements, since it cannot be assumed that the elements are weight free. In such an elastic element wave phenomena might occur, which in turn might cause that the effect of vibroinsulation is opposite to the expected, that is to the limitation of the dynamic influence on the environment. To prevent such a possibility it is necessary to estimate the natural frequency of the vibroinsulating system based on the consideration of the system as a continuous model and discrete-continuous model. In case when the vibroinsulating elements (rubber or tension member) are characterised by their mass distributed evenly, the frequencies for uniform prismatic systems, e.g. rubber systems, might be estimated based on the method presented in the article.

Based on the presented analysis of the proposed control system it can be stated that there exists the possibility of application of that type of control for controlling of the rigidity of the vibroinsulation system of the subgrade. Based on the numerous simulations with different weights of the crossing vehicles and different times of crossing it should be considered to use experimental method for calculation of the PID coefficients for different configurations of the weight and crossing time to dynamically adjust the coefficients based on the information on the speed and weight of the vehicle.

Keywords: vibroinsulation, dynamic influence, control

1. Introduction

The railway tracks used in our country are characterised by a large number of construction solutions. That is the result of local conditions, experience and production and material capabilities of the operators. The basic classification is the distinction between built-in and external tracks. The proposed structure of the trackage consists of the subgrade soil with the concrete bottom slub. On the bottom slub the perforated rubber slubs are assembled which are the elastic element of the vibroinsulation, and on top of the rubber slubs there is a concrete pressure slub which is so called inertial mass. Next on the pressure slub there is a sand blanket with two layers of rubble with variable grain size. The last layer of rubble reaches the level of pre-stressed concrete sleepers with rails attached by means of elastic washers. The attachment of the rails is made by sb 30c springs. In case of urban construction with the trackage on top of it it is necessary to apply double hydro-insulation, which in this case is made of the layer of rubber tapes fixed with the thermoplastic adhesive on the bottom slub and the vibroinsulating perforated rubber slubs.

The design of the vibroinsulation of the rail trackage is shown above. On the plain and levelled ground or an engineering structure, on the consistent subgrade 1 a concrete slub 2 is placed, which might be omitted in case of engineering structures. Then there are placed the perforated rubber slubs 3 of dimension $1000 \times 900 \times 20 \div 40$ mm. On the perforated rubber slubs 3 that constitute the vibroinsulation system there is placed an inertial mass 4 (pressure slub). As the inertial

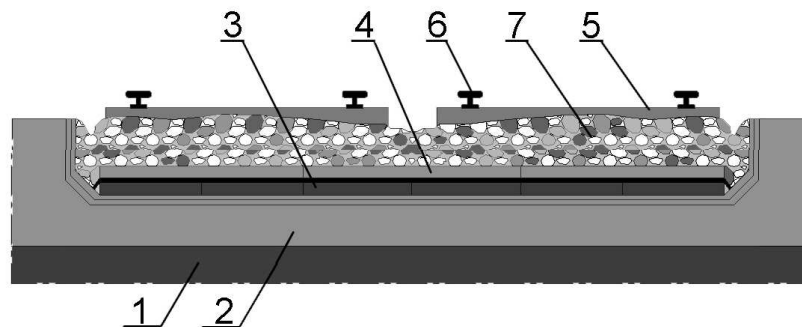

Fig. 1. The track on the vibroinsulating system (platform or viaduct version)

mass concrete slabs might be used. On top of the pressure slub rail sleepers 5 should be mounted with the rails 6, or they should be mounted on the rubble layer 7. All the gaps created when mounting the concrete slabs should be filled with the thermoplastic material, which should prevent water from penetrating the structure. That type of trackage allows uniform distribution of both dynamic and static loads.

The construction of the vibroinsulated trackage, besides the aforementioned advantages, is characterised by the following advantages:

- greater endurance,
- significant limitation of the noise and vibration emission,
- there are no special requirements for the construction equipment,
- construction time is equivalent to the construction time of the traditional trackage.

The disadvantages include:

- more frequent inspections regarding the type of rail assembly,
- additional inspection of water drainage, especially during the autumn time.

Both those disadvantages are also the disadvantages of typical trackages.

To summarise, based on the presented overview, it should be stated that the most beneficial solution in case of railway trackages is the construction of the vibroinsulated trackage presented in the figure 1 for its small dynamic effect and low emitted noise of which a good example might be found at the platforms 2 to 5 of the railway station in Krakow.

Application of any other solution, particularly in large agglomerations or stations brings the danger of excess influence of dynamic effects in the environment during the passage time of the train.

2. Calculation Model of the Vibroinsulation

Six meter long part of the trackage was modelled and the passage of a train was simulated with velocity of 20 kph. The effectiveness of vibroinsulation was

assessed for models with rubber slabs applied and without such application, and for two types of the subgrade that is soil and a steel structure. As an assessment criteria vertical acceleration and displacement of selected points were assumed. The software used for calculations utilises Finite Element Method of Explicit type. The cross-section of the trackage and its structure is presented in the Figure 2. It comprised six-meter long part of the trackage accordingly to the supplied data. It consisted of the following layers:

1. UIC60 rails modelled with the substitute beam elements with rectangular profile;
2. Oak sleepers type IIB modelled with the eight-node solid elements with ratio 500 mm;
3. Rubble layer of thickness 300 mm under the sleepers modelled with the eight-node solids. There was no direct contact between the rail and the rubble;
4. Concrete slab of thickness 120 mm modelled with the eight-node solid elements with steel reinforcement ϕ 14 mm modelled with beam elements with circular profile;

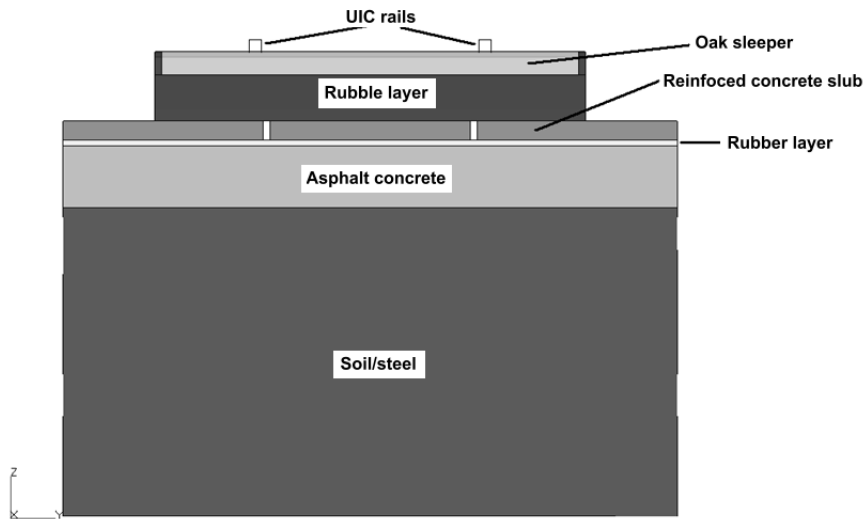

Fig. 2. Structure of the model

5. Rubber layer of thickness 40 mm modelled with the eight-node solid elements;
6. The asphalt-concrete layer of thickness 400 mm modelled with eight-node solid elements;
7. The steel or soil layer of thickness 2000 mm modelled with four-node solid elements. A task of the layer was also to minimise the influence of the boundary conditions on the results of the analysis.

The Fig. 3 presents the Finite Element Model of the the vibroinsulated trackage. Material constants assumed for the calculations are presented in the Table 1.

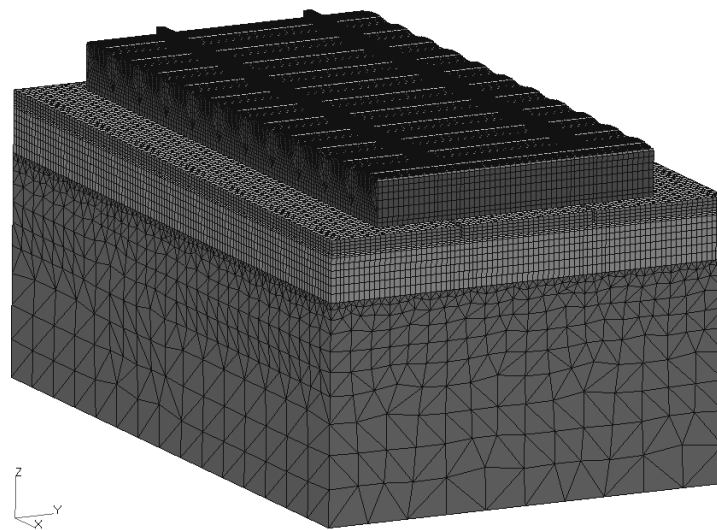

Fig. 3. Finite Element Model of the vibroinsulated trackage

Table 1

Material constants assumed for the calculations

	Oak sleepers	Rubble	Pressure concrete slub	Rubber
Density [t/mm³]	8.38E-10	2.20E-09	2.55E-09	1.20E-09
Viscous damping coefficient	0.04	0.05	0.05	0.05
Poisson Ratio	0.3	0.35	0.3	0.49
Young's modulus [MPa]	11500	4900	30000	7.2

Table 2

	Asphalt concrete	Steel	Soil
Density [t/mm³]	2.50E-09	7.86E-09	1.80E-09
Viscous damping coefficient	0.04	0.02	0.05
Poisson Ratio	0.4	0.3	0.3
Young's modulus [MPa]	28600	2.10E+05	5000

Boundary conditions

The model has been fixed to the ground level or a steel construction (Fig. 4) in normal directions for each surface in a manner similar to the assembly method of a real trackage for the purpose of modelling of the interactions with further layers of the ground or a steel construction.

The load was related to the train passing at maximal allowed velocity of 20 kph (5.55 m/s) with maximal allowed axle load that is 22.5t. The forces was bound to the rail nodes according to the triangle shape with defined amplitude and duration

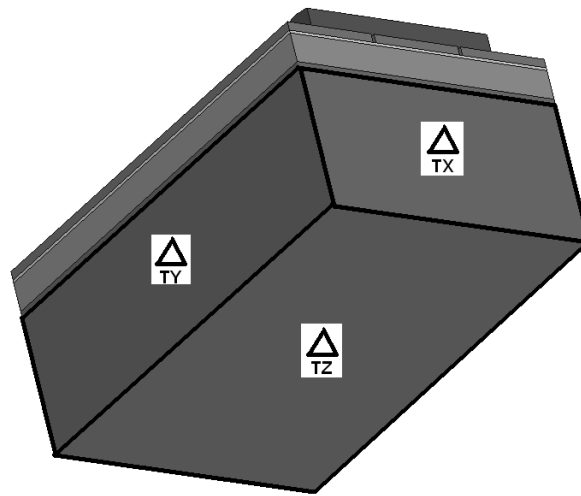

Fig. 4. Boundary conditions for the model

to resemble the velocity of 20 kph. The amplitude of load varied from zero to the maximal value and then back to zero to simulate the passage of the train and for the sake of numeric stability of the model. The characteristics of the load of a single node was shown on the Fig. 5. The triangle was modelled as moving along the rails in time and its maximal value was presented on Fig. 6.

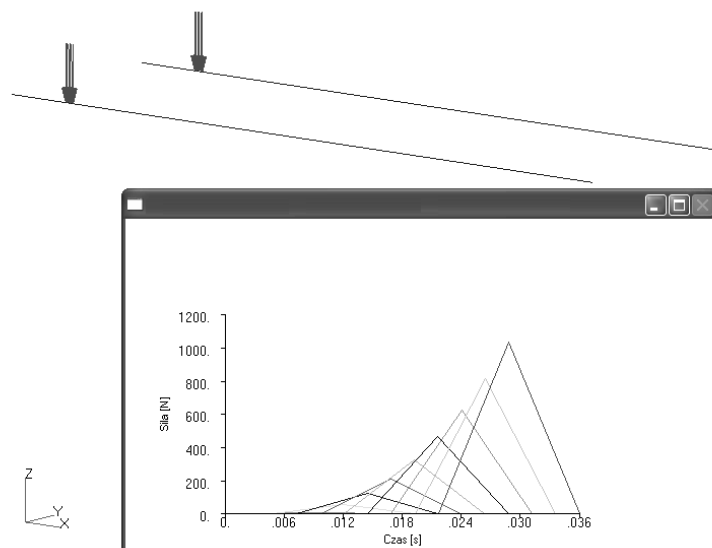

Fig. 5. The method of loading the model by example of few nodes

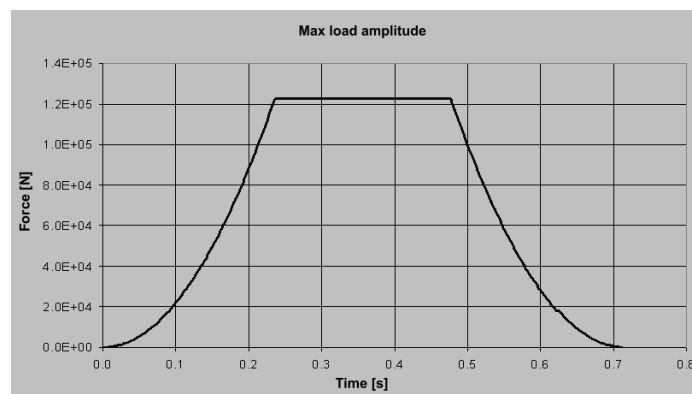

Fig. 6. Maximal amplitude of load as a function of time

The results were presented as a filtered comparison charts of the vertical acceleration and displacement between models with the layer of rubber and without that layer in case of soil subgrade and in case of steel construction. The measurement points were positioned in the layers of concrete in the beginning of the model (measurement point 1) and in the middle of the model (measurement point 2), Fig. 7. Such choice is best for showing of the effectiveness of the rubber vibroinsulation.

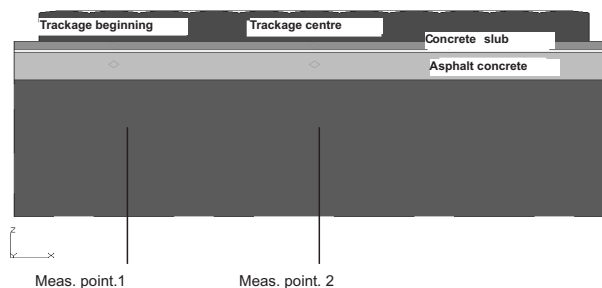

Fig. 7. Positions of measurement points

As an example the accelerations for the model of the trackage located on the soil were presented in the Fig. 8, measurement point 2.

3. The Railway Crossing with Controlled Tension as a Function of Load

The diagram of the vibroinsulation is based on the discrete – continuous model presented in Fig. 9, where the additional vibroinsulation elements are tension members 1, 2 and an element of vibroinsulation made of elastomer 3.

Along with the development and more popular utilisation of the tension member mechanisms in all types of constructions, among others in vibroinsulation systems,

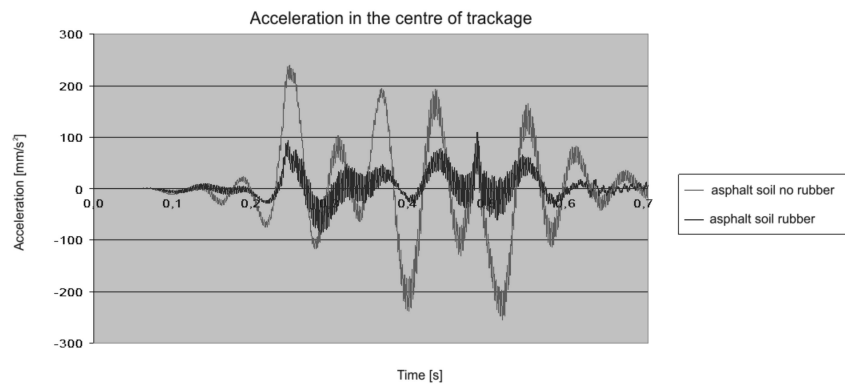

Fig. 8. The comparison of the accelerations for the model of trackage based on the ground, the beginning of the trackage

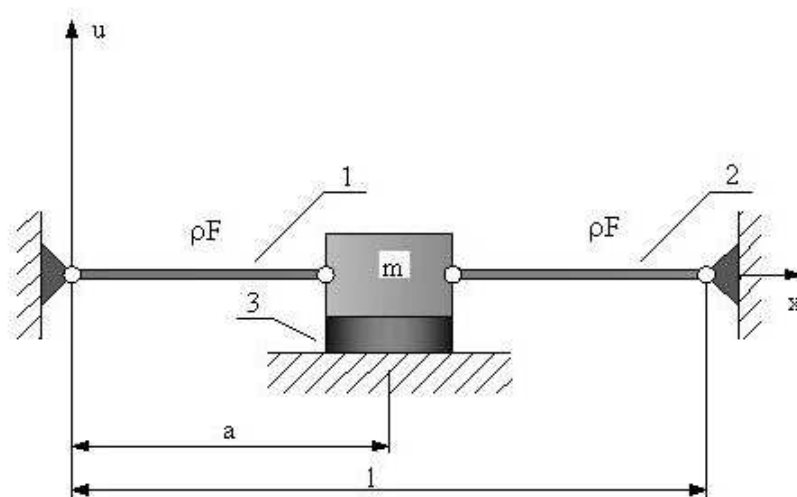

Fig. 9. The model of the vibroinsulation system for the railway crossing

it is important to include into calculations and experiments the dynamic loads of the tension member with the mass attached to it. The dynamic load causes the vibration of the system which in turn produces additional dynamic loads in the tension member. Especially with the calculation of strength of the materials it is important to consider that type of loads since they can reach values exceeding the static loads.

3.1. Theoretic analysis

Knowing the dynamic loads of the tension member, one can create mathematical model describing the vibration that occurs in the tension member under that

load. The definition might be presented as a system of partial differential equations or differential-integral equations. Such analytic description of vibration might be produced only for some model of the real object. The model is constructed by introduction of simplification that is idealisation of the real model. The model built that way, depending on the assumed simplifications, more or less similar to the real object. Of course the smaller the number of simplifications the model is more accurate for the vibration description and the more complex is the analytic description and the more complex analysis. For the most accurate description of the tension member a mechanical system is assumed with continuous distribution of the weight with proper boundary conditions. Of course the solution of such a system of equations is extremely difficult, not even mentioning the accurate solution. The basic dynamic parameter of the tested tension system is its natural frequency. The values of natural frequency decides on the values of dynamic loads of the tension member.

The characteristic feature of the tension member dynamics is that it is inseparably bound to the statics of the tension member. That circumstance allows analysis of the vibration independently to the statics of the tension member.

Let us consider the model of the tension member vibrating only in the plane of hanging (Fig. 10). The position of any profile of the tension member during the vibration, and more precise of its geometric centre A_0 is defined by the coordinates:

$$x_e = x_e(x, y, t) \quad y_e = y_e(x, y, t)$$

where: x, y – coordinates of the centre of the profile A in its equilibrium position related to which small vibration is analysed; t – time

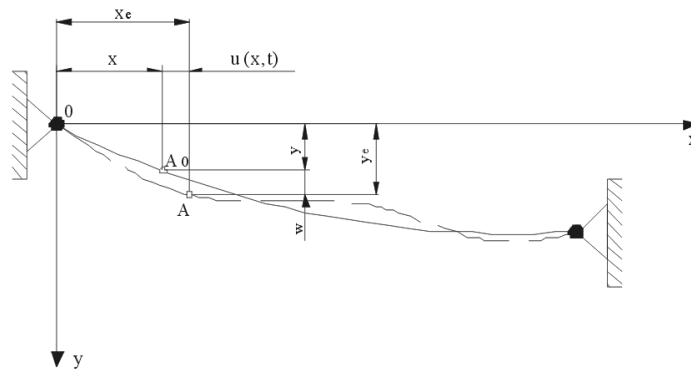

Fig. 10. Displacement of the point on the flexible tension member during the vibration in the plane of hanging

Based on the figure 10 one can state that there exist the following dependencies between the coordinates x_e, y_e, x, y

$$x_e(x, y, t) = x + u(x, t), \quad y_e(x, y, t) = y(x) + \omega(x, t)$$

where: $u(x, t)$ – component of the displacement of the point A in the direction x during vibration;

$\omega(x, t)$ – component of the displacement of the point A in the direction y during vibration.

The system of equations (1) that describes the vibration of the flexible tension member in the hanging plane has the following form:

$$\begin{aligned} \frac{m}{\cos\alpha_0(x)} \frac{\partial^2 \omega(x, t)}{\partial t^2} = \frac{\partial}{\partial x} \left[T(x) \frac{\frac{\partial \omega(x, t)}{\partial x} - \varepsilon(x, t) y'(x)}{1 + \varepsilon(x, t)} \cos\alpha_0(x) \right] + \\ + \frac{\partial}{\partial x} \left[N(x, t) \frac{\frac{\partial \omega(x, t)}{\partial x} + y'(x)}{1 + \varepsilon(x, t)} \cos\alpha_0(x) \right] + p_y(x, t) \end{aligned} \quad (1)$$

where:

m – the mass of the length unit of the tension member not distorted by vibration [kNs^2/m^2];

$p(x, t)$ – variable in time external load of the tension member assigned to the length unit measured along the x axis, driving the vibration of the tension member [kN/m];

$T(x)$ – normal tension kN in the tension member occurring under the static load $q(x)$;

$N(x, t)$ – total tension kN in the tension member during the vibration;

$\alpha_0(x)$ – the angle between the tangent line and the tension member in the point $A_0(x, y)$ rad, in the static equilibrium;

$\varepsilon(x, t)$ – relative extension of the tension member occurring during the vibration;

Solution of the equation system for vibration of the tension member is, as it was mentioned before, very complex, and that is why it is assumed that the equations describe the vibration with small hang, which is a frequent case. It is assumed that the tension member has a small hang when the value of the hang f_0 does not exceed 1/8 of the distance between the supports. The above system of equations is successively simplified leading to simpler equations. Let us introduce the following definitions:

$$T(x) \cos\alpha_0(x) = H_{st}$$

$$N(x, t) \cos\alpha_0(x) = H_d$$

where:

– the value H_{st} is called the static horizontal component of the tension, when $q_x = 0$ its value is constant;

– the value H_d is called dynamic horizontal component of the tension.

Assuming that the displacement of the elements of the tension member in the direction of x axis are small enough to state:

$$\frac{\partial u}{\partial x} \ll 1$$

we receive the system of non-linear equations for vibration of the string with high amplitudes introduced by G. Kirchhoff:

$$\left. \begin{aligned} m \frac{\partial^2 \omega}{\partial t^2} &= H_{st} \frac{\partial^2 \omega}{\partial x^2} + EF \frac{\partial}{\partial x} \left[\varepsilon(x, t) \frac{\partial \omega}{\partial x} \right] \\ m \frac{\partial^2 u}{\partial t^2} &= EF \frac{\partial \varepsilon}{\partial x} \\ \varepsilon &= \frac{\partial u}{\partial x} + \frac{1}{2} \left(\frac{\partial \omega}{\partial x} \right)^2 \end{aligned} \right\} \quad (2)$$

In case of small amplitudes, when:

$$\left(\frac{\partial \omega}{\partial x} \right)^2 \ll \frac{\partial u}{\partial x} \quad \text{and} \quad EF \frac{\partial}{\partial x} \left[\varepsilon(x, t) \frac{\partial \omega}{\partial x} \right] \ll H_{st} \frac{\partial^2 \omega}{\partial x^2}$$

we receive the classic equation of the string vibration

$$\left. \begin{aligned} m \frac{\partial^2 \omega}{\partial t^2} &= H_{st} \frac{\partial^2 \omega}{\partial x^2} \\ m \frac{\partial^2 u}{\partial t^2} &= EF \frac{\partial^2 u}{\partial x^2} \end{aligned} \right\} \quad (3)$$

Assumed for dynamic analysis mathematical model must be significantly simplified for the sake of simple analytic solution. It does not consider many non-linear phenomena that occur in such type of technical vibration. Based on the analysis one can estimate the natural frequency of the model presented in Figure 3.8, that allows the choice of parameters of the vibroinsulation system for flexible railway crossing to minimise the dynamic effects on the surrounding and thus extend the maintenance periods and increase the passage velocity with the same dynamic parameters of both the rail-vehicles and road-vehicles. In the vibroinsulation system for the railway crossing presented in Figure 1 it was assumed:

- m – substitution mass resembling the mass of the truck,
- ρ – density of the wire rope (mass density),
- F – intersection of the rope,
- H_{st} – static horizontal component of the tension – the controlled value,
- H_d – dynamic horizontal component of the tension – the controlled value.

The differential equations of the movement describing the natural vibration of the system take the form:

$$\left. \begin{aligned} \rho_1 F_1 \frac{\partial^2 u_1}{\partial t^2} &= H_{st} \frac{\partial^2 u_1}{\partial x^2} + y_1'' H_d \\ \rho_1 F_1 \frac{\partial^2 u_2}{\partial t^2} &= H_{st} \frac{\partial^2 u_2}{\partial x^2} + y_2'' H_d \\ \frac{\partial^2 u_1(a, t)}{\partial t^2} &= a^2 \frac{\partial^2 u_1(a, t)}{\partial x^2} \end{aligned} \right\} \quad (4)$$

where: $a^2 = \sqrt{\frac{E}{\rho}}$,

E – dynamic modulus of the rubber element,
 ρ – density of the rubber element;

$$H_d = \frac{EF}{l} \left[\int_0^a \frac{\partial u_1}{\partial x} y_1'(x) dx + \int_a^l \frac{\partial u_2}{\partial x} y_2'(x) dx \right].$$

The solution of the equation system (3) must meet the following four boundary conditions:

$$u_1(0, t) = 0, \quad u_2(l, t) = 0, \quad u_1(a, t) = u_2(a, t) \quad (5)$$

$$m \frac{\partial^2 u_1(a, t)}{\partial t^2} + \frac{EF}{l} \frac{\partial u(a, t)}{\partial x} + H_d [y_1'(a) - y_2'(a)] + [H_{st} + H_d] \cdot \left[\frac{\partial u_2(a, t)}{\partial t} - \frac{\partial u_2(a, t)}{\partial x} \right] = 0 \quad (6)$$

After estimation of the natural frequencies f_i ($i=1, 2, \dots, \nu$) of the presented above model of the crossing system, it is possible to control the tension of the tension member H to fulfil the condition of the vibroinsulation, that takes the form:

$$\frac{f}{f_0} \geq \sqrt{2} \quad (7)$$

In case of discrete-continuous system, as it was mentioned before, the condition of the technical vibroinsulation (7) cannot be met and it should be weakened, by assuming:

$$f_{oi} < f_w < f_{oi+1}$$

where: $i=1, 2, 3, \dots, n$

3.2. The control

To gain information on the vibroinsulation system with variable tension controlled depending on the load of the crossing, a mathematical model was assumed with a diagram presented in the Fig. 11.

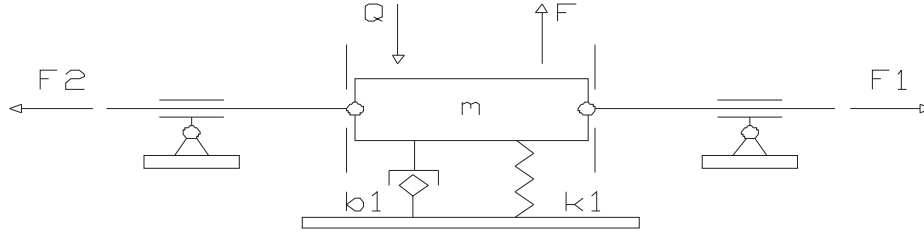

Fig. 11. Diagram of the vibroinsulation system

For such model a dynamic equation might be written for movement along the y axis in the form presented below:

$$m\ddot{y} + b_1\dot{y} + k_1y = Q(y)$$

The above equation presents the mathematical definition of the model. The correlation of the effects of load Q of the vehicle with the tension F1 and F2 in tension member was modelled by introduction of proper tension members with length l connected to two actuators symmetrically fixed on the x axis. Presented in the model rigidity k1 and attenuation b1 define reaction of the foundation on the vibroinsulation system. To correlate both forces occurring in the system the coordinate system was introduced with y axis in the direction of the Q force, but the opposite sense and the x axis was assumed in the directions of F1 and F2 forces.

From the analysis of the system it might be seen that the optimal solution is the application of the closed loop control system since only in that way we are able to compensate the displacement in the y axis that is an effect of the weight of the crossing vehicle. So the basic purpose of the control system is the active influence on the vibroinsulation system. From the mathematical model the control system estimates the displacement in the y axis, for known excitation, based on that unwanted deviation is calculated that should approach zero. The method the control system determines the control signal depends on the type of control. In case of control of the vibroinsulation system the general structure of the control system was presented in the Fig. 12.

In the above presented control system the following description of the signals and elements is found:

- r(t) – The reference signal;
- u(t) – The control signal;
- y(t) – Output from the object;
- e(t) – Error signal r(t)-y(t);
- a(t) – Active signal;
- b(t) – Output from the feedback loop;

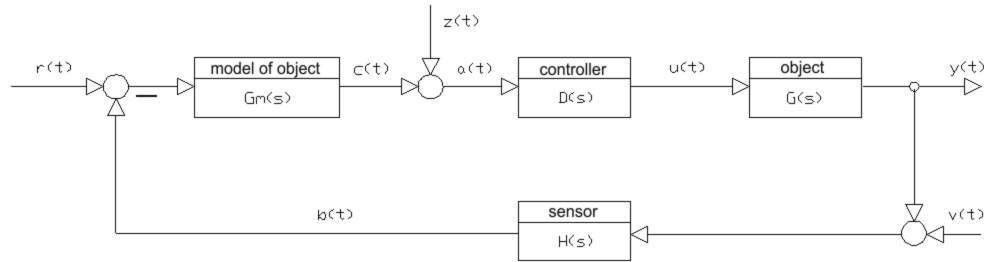

Fig. 12. The block diagram of the analysed control system with single feedback loop

- $c(t)$ – Output from the model of the object;
- $G_m(s)$ – Transmittance of the model of the object;
- $H(s)$ – Transmittance of the sensor;
- $D(s)$ – Transmittance of the controller;
- $G(s)$ – Transmittance of the controlled object;
- $z(t)$ – Interference influencing the object;
- $v(t)$ – Noise of the sensor.

The presented structure of the control system of the vibroinsulation system was chosen, as it was mentioned before, to minimise the displacement of the platform in the y axis. That is by $r(t)$ one should understand the weight, expressed in [N] of an object moving on the vibroinsulation system. The weight of the crossing vehicle should be calculated by the scale located few meters before the crossing. This results from the fact that the signal related to the weight is introduced into the model of the object to calculate the theoretical displacement $c(t)$ of the platform. The calculated displacement $c(t)$ in [m] is compared to the interference of the object. In the analysed case our signal $z(t)$ describes the set displacement of the platform which by definition is zero. That way we get the $a(t)$ signal, which is the difference between the interference and the output from the model of the object and is fed to the controller. With the correct setup of the controller on its output a control signal is achieved that is represented by a force expressed in [N], that should be applied to the vibroinsulation system to prevent the displacement of the platform in the y axis.

To perform the simulation of the assumed control system the analysed vibroinsulation system was modelled in the Matlab-Simulink environment. The Fig. 13 below presents the model of the vibroinsulation system.

One of the most important elements in the process of the design of control systems is the assumption of the proper structure of the system and the optimal setup of the controller. In the analysed case the control system should be equipped with the PID controller.

Often among the requirements for the control systems one can find an overshoot in between 0 to 5% and the minimal settling time t_r .

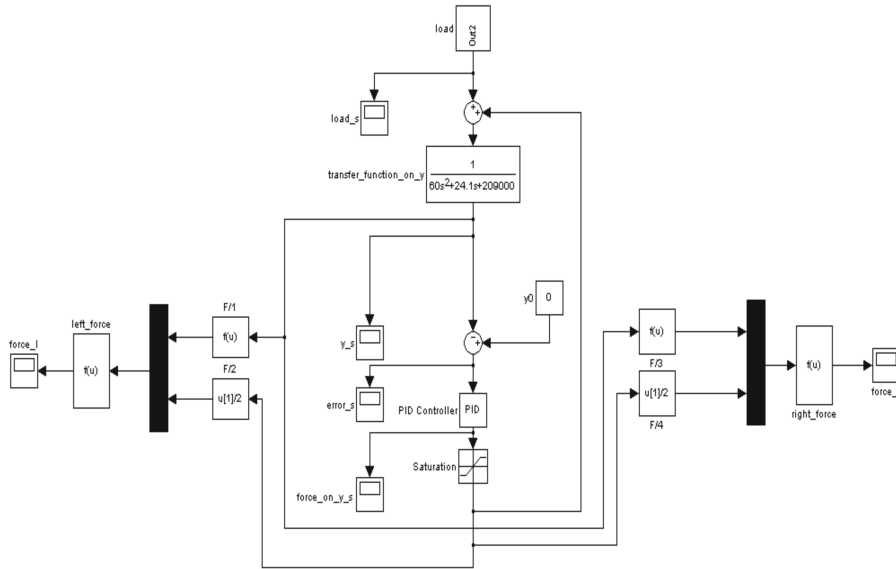

Fig. 13. The block diagram of the analysed control system modelled in the Matlab-Simulink environment

The proposed PID controller is an element that performs the following law of the regulation:

$$u(t) = K_p e(t) + K_i \int e(t) dt + K_d \left(\frac{d}{dt} e(t) \right)$$

where:

- K_p – Proportional coefficient;
- K_i – Integral coefficient;
- K_d – Derivative coefficient.

The assumption of the PID controller structure was caused by the fact that the vibroinsulation system requires extended effect on the controller setup. Often met in practice is a PID controller with real derivative component:

$$G_{PID}(s) = K_p + \frac{1}{T_i s} + \frac{T_d s}{\tau s + 1}$$

$$G_{PID}(s) = K_p + \frac{K_i}{s} + \frac{K_d s}{\tau s + 1}$$

The derivative component realised in practice includes small inertia so that the time constant of the inertial filter is in the range $\tau = (0.05 \div 0.25) T_d$. To perform the computer simulation of the vibroinsulation system and choice of proper PID setup

there was assumed and written the model of the controlled object in the form of the transfer function:

$$\frac{Y(s)}{U(s)} = \frac{1}{ms^2 + b_1s + k_1}$$

For simulation calculation the following values were assumed for mass, damping coefficient and the elastic coefficient:

$$\begin{aligned} m &= 60 \quad [\text{N}] && - \text{The mass of the platform;} \\ b_1 &= 24.1 \quad [\text{Ns/m}] && - \text{The damping coefficient;} \\ k_1 &= 209000 \quad [\text{N/m}] && - \text{The elastic coefficient.} \end{aligned}$$

According to the assumed notation on the input of the control system there will appear the signals defining the weight Q of the vehicle passing in the time. Based on the time series $c(t)$ and $z(t)$ the difference in displacement was calculated and fed into the PID controller. As a result of simulations the coefficients of the controller were calculated:

$$\begin{aligned} K_p &- 900000 \\ K_i &- 2000 \\ K_d &- 10000 \end{aligned}$$

Based on the assumed values in the output of the controller the time series of a force was generated for counteracting the weight of the vehicle to keep the set position of the platform. Below in the figure 14 the counteracting force $F[\text{N}]$ was presented.

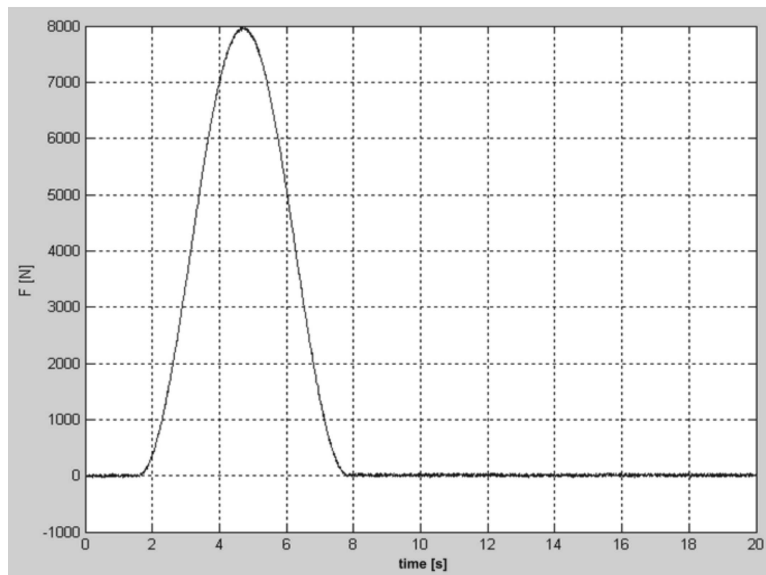

Fig. 14. Time series of the force $F - u(t)$

The achieved signal $u(t)$ is a control signal that should be fed into the object. For the sake of the method of distribution of the F force to the actuators the F_1 and F_2 forces were calculated for the actuators 1 and 2. The Figures 15a and 15b present the values of the forces that must be generated for the vibroinsulation system to compensate the displacement in the y axis.

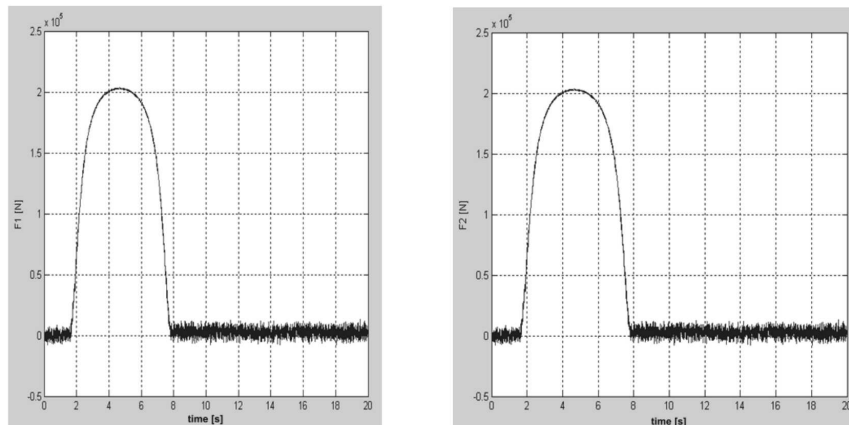

Fig. 15. a) and b) Time series of forces F_1 and F_2 in actuators 1 and 2 – $y(t)$

4. Summary

1. The results of calculation presented in the chapter 2 on the charts of acceleration show significant influence of rubber vibroinsulation on the level of vibration transferred through trackage to the further layers, that is the ground and steel constructions in a positive sense
2. For verification of calculations measurements on the ready track are recommended
3. Based on the above conducted analysis of possibilities of vibroinsulation of the track subgrade, which aim at the protection from the vibration and limitation of the generated noise, there should be a number of elements taken in the consideration, necessary for the correct exploitation, that is:
 - vibroinsulation slub for which physic and mechanic properties should be tested;
 - pressure slub of reinforced concrete of thickness 120 mm;
 - asphalt-concrete layer;
 - hydroinsulation layer;
 - dilatation sealing;
 - safety requirements;
 - conditions for modification or repair.

In case of complex objects of vibroinsulation when the mass of the vibroinsulator is significant, and that is the case of the transporting machines and devices, when the geometric dimensions of the elements of vibroinsulation system are similar to the slab, where the process of modelling of the vibroinsulation mechanism as a discrete system, creates extreme hazards when the vibroinsulation is chosen without consideration of its mass. The most serious of the hazards is occurrence of the wave effect of the spring-dumper elements, since it cannot be assumed that the elements are weight free. In such an elastic element wave phenomena might occur, which in turn might cause that the effect of vibroinsulation is opposite to the expected, that is to the limitation of the dynamic influence on the environment. To prevent such a possibility it is necessary to estimate the natural frequency of the vibroinsulating system based on the consideration of the system as a continuous model and discrete-continuous model. In case when the vibroinsulating elements (rubber or tension member) are characterised by their mass distributed evenly, the frequencies for uniform prismatic systems, e.g. rubber systems, might be estimated based on the method presented in the article.

Based on the presented analysis of the proposed control system it can be stated that there exists the possibility of application of that type of control for stabilisation of the vibroinsulating platform. Based on the numerous simulations with different weights of the crossing vehicles and different times of crossing it should be considered to use experimental method for calculation of the PID coefficients for different configurations of the weight and crossing time to dynamically adjust the coefficients based on the information on the speed and weight of the vehicle.

References

1. Adamczyk J., Stojek Z., Targosz J.: *Wibroizolacja podtorzy szynowych*. PAN, Mechanika 15, 1991.
2. Braunl T.: *Embedded Robotics*, Springer-Verlag, 2008.
3. Gerolymos N., Gazetas G.: Static and dynamic response of massive caisson foundations with soil and interface nonlinearities—validation and results, *Soil Dynamics and Earthquake Engineering*, 26, 377-394, 2006.
4. Hassen G., Abdelkrim M., de Buhan P.: Finite element implementation of a homogenized constitutive law for stone-column reinforced foundation soils, with application to the design of structures. *Computers and Geotechnics*, 37, pp. 40-49, 2010.
5. Reace P.: *Progress of Smart materials and Structures*, Nova Science Publishing, 2007.
6. Shinskey, G.: *Process Control Systems: Application, Design & Tuning*, McGraw-Hill, 1996.
7. Sr Srinivasan, A.V., McFarland, D.M.: *Smart structures*, Cambridge University Press, 2000.
8. Targosz J.: *Układy wibroizolacji w transporcie szynowym i samochodowym*, Rozprawy, Monografie UWND, 2007.