

*synchronous generator, non-salient field winding, high speed,  
brushless excitation, autonomous electrical power system*

Filip KUTT\*, Grzegorz KOSTRO\*,  
Michał MICHNA\*, Mieczysław RONKOWSKI\*

## **STUDY OF PROTOTYPE MULTI-POLE NON-SALIENT FIELD WINDING FOR HIGH SPEED BRUSHLESS SYNCHRONOUS GENERATOR**

In this paper a non-salient field winding for a brushless synchronous generator working with high speed in an autonomous energy generation system (e.g. airplane power grid) has been presented. A conception of a six-pole cylindrical-rotor with distributed field winding has been proposed. Comparison study of salient and prototype non-salient field winding has been carried out. Chosen simulation and measurement results of the generator stator voltage and current waves have been presented.

### 1. INTRODUCTION

Energy have become collective concerns that are motivating (and motivating factor to) many research, education and outreach programs. It is a beginning to be recognized that the development and demonstration of advanced power electronics technologies provides one of the largest opportunities for more efficient energy utilization and versatile energy generation. Presently, as result of those opportunities, distributed generation systems and autonomous electric power systems (AEPS) are more and more applied. The key elements of these systems are high speed brushless synchronous generators [1, 2, 4].

In this paper a non-salient field winding for a brushless synchronous generator (BSG) working with high speed in an autonomous energy generation system (e.g. airplane power grid) has been presented. A conception of a six-pole cylindrical-rotor with distributed field winding has been proposed. Comparison study of salient and prototype non-salient field winding has been carried out.

---

\* Politechnika Gdańska, Wydział Elektrotechniki i Automatyki, ul. Narutowicza 11/12, 80-233 Gdańsk.

## 2. BRUSHLESS SYNCHRONOUS GENERATOR

The BSG is a combined power generation device, i.e., a three-stage machine topology. It is composed of three electrical machines on common shaft: subexciter, brushless exciter and synchronous generator itself, as shown in Fig. 1. As a subexciter a permanent magnet generator (PMG) is used to supply the field winding of the brushless exciter. The generator control unit (GCU), ensures voltage control and usual protections. In case of the variable high speed operation, to ensure the voltage control (rms and frequency values) requirements of the power grid, the excitation system has to be properly design.

In aeronautic applications the volume and weight of the power generation devices are a key issue. As it is well known, a high speed power generation devices will have the volume and weight smaller than a low speed device. On the other hand, as consequence of the high speed operation, the centrifugal forces on the rotor and the limitation of the rotor and shaft diameters are increased [1, 2]. Moreover, you have to consider an increased hysteresis losses, skin effects and eddy currents [1, 2].

BSG applied on board of a modern aircraft have high rotation speed ranging from 8000 to 16000 rpm, and even more. Therefore, a non silent pole excitation of the main generator is more adequate than silent pole structure used in present constant frequency BSG.

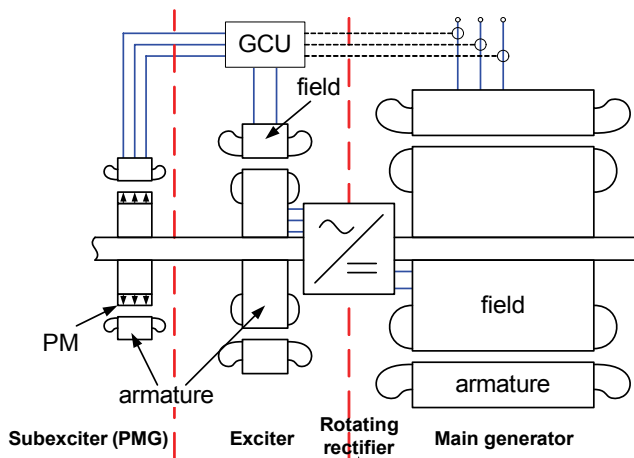

Fig. 1. Variable high speed autonomous power generation system

– a system based on a three-stage electrical machine topology:

subexciter – permanent magnet generator (PMG); brushless exciter – synchronous machine

with stationary field winding, rotating armature winding and rotating diode rectifier;

main generator – synchronous machine with rotating field winding; GCU – generator control unit [1]

### 3. DESIGN OF MULTI-POLE NON-SALIENT FIELD OF THE MAIN GENERATOR

The design of the prototype generator is based on the Russian silent pole BSG type GT40PCz8 ( $S_n = 40$  kVA,  $U_n = 208$  V, p.f. = 0.8,  $n_n = 8000$  rpm) applied in the MI-28 helicopter. The salient field winding of the main generator has been replaced by a designed and built non salient pole field winding (Fig. 2). This approach has given a cheap possibility to compare the both structures – the salient and the prototype non-salient field windings.

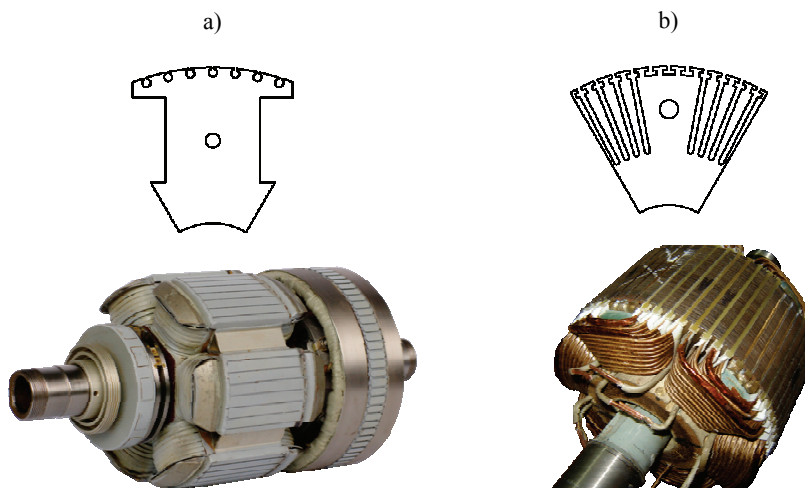

Fig. 2. Two types of exciter of the main generator: a) silent pole (original structure, exciter and subexciter on one shaft), b) non-silent pole (new designed structure, temporally exciter and subexciter removed form shaft)

The design process was based on the assumption that the new exciter of the main generator part of BSG should have as much slots as possible and the excitation winding should be properly designed to generate a sinusoidally distributed induction in the air-gap. Moreover, the high number of slots should allow to achieve higher rotational speeds than 8000 rpm. The outer diameter of the new filed structure of the main generator is  $D_r = 173.8$  mm, the air-gap length is  $d = 0.6$  mm and the core length is  $l = 73$  mm.

The FEM simulations (using FLUX software) have been carried out to verify the designed BSG using analytical calculations [5]. For the FEM analysis a magnetic materials with different parameters were selected for the stator and the rotor cores. The material selected for the stator has at beginning  $\mu_r = 8000$  and saturation magnetization 1.6 T. The parameters of the rotor core, due to laser cutting of the steel sheets, have changed significantly its magnetic characteristic in the teeth area. The rotor permeability was evaluated using the data of M530-50A steel sheets (at beginning  $\mu_r = 500$

and the saturation magnetization 1.55 T). Table 1 shows maximum values of magnetic field densities in the crucial parts of designed machine.

In Figures 3 and 4 are shown the simulation results at 50% of nominal load of the generator. The field and armature windings are supplied by 50% of the rated currents and power factor (PF) is 0.8. The fundamental component amplitude of air-gap flux density at 50% load condition is 0.75 T.

Table 1. Maximum values of flux density of the main generator

Part of magnetic circuit	Flux density [T]	Part of magnetic circuit	Flux density [T]
Airgap flux density	0.83	Rotor yoke flux density	1.1
Stator yoke flux density	1.35	Rotor tooth flux density	1.65
Stator tooth flux density	1.55		

FEM simulations have verified the calculated parameters and dimensions of the main generator. Similar calculations were carried out for the exciter and subexciter as well as for the original silent pole main generator, in order to verify some assumptions for FEM analysis such as current densities and number of turns of unmodified parts of the BSG.

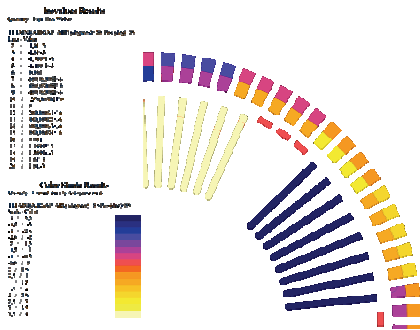

Fig. 3. FEM simulation results at 50% rated load (PF = 0.8)

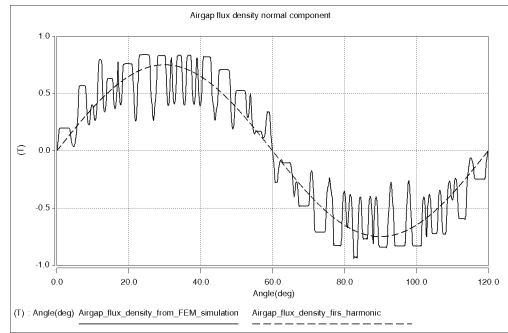

Fig. 4. Airgap flux density distribution (normal component) at 50% nominal rated (PF = 0.8)

#### 4. SIMULATIONS AND MEASUREMENTS RESULTS

FEM simulations and measurements were carried out for the no-load (open circuit) characteristic of the BSG with prototype non salient field wind and the silent pole BSG type GT40PCz8. In Fig. 6 are shown the simulation and measurements results of the no-load phase voltage and phase voltage and line currents under load. For both simulations (no-load and load) the excitation current has the same values.

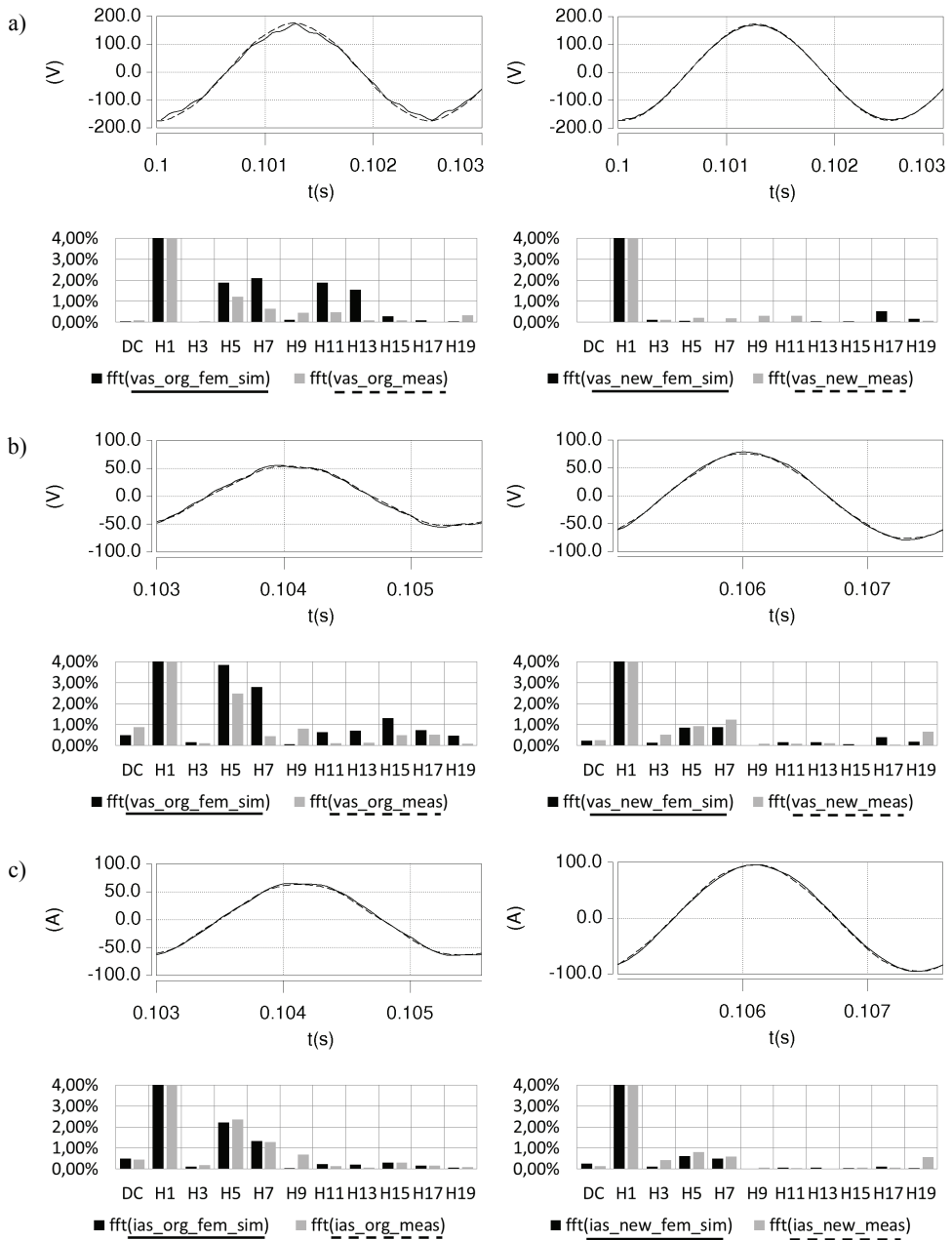

Fig. 5. Comparison study of salient (original) and non-salient (prototype) field windings – FEM transient simulation and measurement results: a) no-load back emf, b) phase voltage under load ( $R = 0.8 \Omega$ ), c) line current under load ( $R = 0.8 \Omega$ )

## 5. CONCLUSIONS

The BSG with the prototype non-salient field winding is characterized by greater compactness (its mass/volume factor is relatively small). Moreover, its no-load phase voltage and the phase voltage and line currents under load contain less higher harmonics than the voltages and current of the silent pole generator (GT40PCz8).

The design and magnetic field analysis of the BSG with the prototype non-salient field winding are very reliable, due to the application of the two approaches: analytical (based on the circuit model and sizing equations) and numerical (using field simulator FLUX2D). Using them you can avoid the costs of building farther prototypes of the machine under design.

## REFERENCES

- [1] DELHASSE F., BIAIS F., *High power starter generators for airlines*, Changes in Aeronautical and Space Systems. Challenges for on-Board Energy, June 26–28, 2006, Avignon, France, 1–3.
- [2] GIERAS J.F., *Advancements in electric machines*, Springer, 2008.
- [3] KUTT F., RONKOWSKI M., *Conception and field simulations of a variable frequency generator. Application for autonomous power generation system* (in Polish), *Zeszyty Problemowe – Maszyny Elektryczne*, No. 86, 2010, 169–173.
- [4] MOIR I., SEABRIDGE A., *Aircraft systems. Mechanical, electrical, and avionics subsystems integration*, 3rd ed., United Kingdom, John Wiley & Sons, Ltd., 2008.
- [5] PYRHÖNEN J., JOKINEN T., HRABOVCOVÁ V., *Design of Rotating Electrical Machines*, United Kingdom, John Wiley & Sons, Ltd., 2008.
- [6] YONG J., KOSTRO G., KUTT F., MICHNA M., and RONKOWSKI M., *Conception and design of a hybrid exciter for brushless synchronous generator. Application for autonomous electrical power systems*, *Zeszyty Naukowe Politechniki Śląskiej, Elektryka*, No. 1(213), 2010, 7–21.