

Shunt power electronic buffer as active filter and energy flow controller

ANDRZEJ SZROMBA

*Faculty of Circuit Theory and Electronics
Cracow University of Technology*

e-mail: aszromba@pk.edu.pl

(Received: 12.06.2012, revised: 01.10.2012)

Abstract: The considered shunt active power filter can be controlled not only to compensate non-active current in the supply source, but additionally to optimize energy flow between the source and the load. In such a case the filter shapes the source current to be active and simultaneously regulates its magnitude. The presented filter/buffer can operate properly even when the load contains *AC* or *DC* variable energy source of any characteristic. The device can optimize energy flow for a single load, but also for a group of loads as well. The distinctive feature of the employed control method of the filter/buffer is that certain changes of energy stored in the device are utilized as the source of information concerning the active current of the load. This control method is very flexible and can be implemented to nearly all structures of active filters, for *DC*, single- and multiphase circuits.

Key words: active power filter, active current, power control, power quality

1. Introduction

Each electric load needs current and voltage interaction to work. The supply source effort, the apparent power, is almost always greater than the load active power. The shunt active power filter (*SAPF*) can alleviate the source-and-load incompatibility. This can reduce source current to optimal shape and magnitude and the energy transfer between the source and the load can be more effective, without excessive supply voltage drop and loss of energy on line impedance.

Compensation of the non-active current could be beneficial even if the supply source is electrically ideal, e.g. without internal impedance. In a multiphase circuit the *SAPF* can balance source currents. The supply source, treated as a complex mechanical-and-electrical energy converter, can act with regular turbine rotation – even if the electric load is unbalanced.

SAPFs are built mostly for three-phase systems [1-4, 9, 11, 15, 19, 20, 23, 24]. Some filters are dedicated to single-phase circuits [13, 16, 17, 25]. However, non-active current may appear also in a circuit consisting of *DC* sources and switched loads. For that reason *DC* active

filters should be also developed [31]. Active filters use capacitors or inductors as energy storages and employ voltage- or current-source converters [28]. Nowadays voltage-source converter filters are preferred, but the importance of current-source filters may progress with development of superconducting materials technology [14, 27]. Shunt active filters can also be classified from the control techniques, or from the filter reference run extraction method point of view [2, 9, 12, 21, 29, 32].

The described in the literature *SAPFs* cannot control the active energy flow between the source and the load. The method of active filter control presented in the paper allows adjusting energetically a variable passive/active load with source.

In the first part of the paper, Sections 2-4, the specific method of *SAPF* control is discussed. It is based on Fryze's idea of load equivalent conductance. The conductance is determined by magnitude of energy stored in the filter reactance elements. Then the new possibility of controlling by the filter of active energy flow between the supply source and the load is considered. The control method discussed may be easily adapted for *DC*, single-phase *AC* and multiphase circuits. The main filter structure considered is voltage source full-bridge inverter.

All presented plots are obtained by using SPICE simulating software.

2. Energy relations between supply source, load and active filter

A) Circuit block diagram

Generally the active filter studied in this paper may be considered as a simple arrangement of four functional stages as shown in Figure 1.

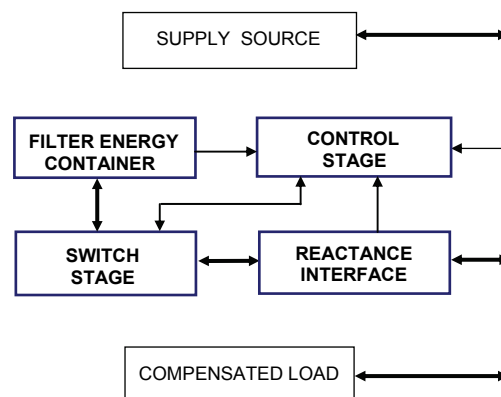

Fig. 1. General diagram of considered shunt active power filter

Control Stage processes signals of currents and voltages of the supply source, of the compensated load, and of the active filter. **Filter Energy Container** acts as a source of energy used to force filter's current. The container has to be initially charged to a relatively large

magnitude of energy. A capacitor (or inductor) is employed as this energy-storing element. **Switch Stage** is an arrangement of power switches. **Reactance Interface** is an inertial circuit, which smoothes energy flow between the filter energy container and the supply source.

The problem of system instability may occur if the source is not stiff. The **Supply Source** is modelled as a real one, with internal resistance $R = 2 \text{ m}\Omega$ and inductance $100 \text{ }\mu\text{H}$. However, the considered active filter acts properly even if the resistance and inductance are modelled as several times greater. This is due to the Signal processing block, Figure 4, which should be considered as a low-pass filter. An additional capacitor may be also used in cooperation with the active filter input inductor.

The **Compensated Load** is modelled almost always as non-linear and varying in time. The load current is shown in every presented example.

B) Equivalent conductance and active current

Making assumption that the active current is in a proportion with non-distorted supply voltage (*EMF*), the factor of proportionality is the only information needed to adjust the source current to be active. In order to obtain the factor, the Fryze's concept of active current is very practical [5-8, 10]. The Fryze's active current i_p is determined by using the idea of the load equivalent conductance G_{Tn} (for the n -th T period of supply source cycle). The equivalent conductance may serve as the factor of proportionality. In the basic form, to be useful for non-active current compensation, the Fryzes's concept may be generally summarized as follows (1):

$$i_{p,Tn} = G_{Tn}u_S = \frac{P_{L,Tn}}{U_S^2}u_S, \quad (1)$$

$$P_{L,Tn} = \frac{1}{T} \int_{(n-1)T}^{nT} u_L i_L dt, \quad (2)$$

where: $n = 1, 2, 3, \dots$, u_L , i_L are load voltage and current, u_S is supply voltage, U_S is *RMS* of source voltage

The active current signal (1) may be utilised as the reference for the source current: $i_{S,Tn} = i_{p,Tn}$. The load active power has to be known to calculate the load equivalent conductance (1), (2). The integral definition (2) requires measuring the load voltage and current. In the paper the load active power is obtained in other way: energy relations between the active filter, the supply source and the load are essential for the presented method of active filter control [26].

C) Active current calculation

The idea of the method is focused on the first period T_1 of the active filter action. Let the active filter be ready to work, the active filter energy container (Fig. 1) is charged to the initial magnitude W_{AF0} and the initial magnitude of the equivalent conductance G_0 is assumed to be zero. Then the load is switched on (Fig. 2).

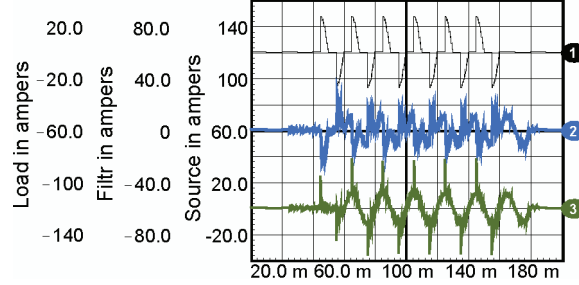

Fig. 2. Active filter action. Load (1), active filter (2) and source (3) currents

Because of the definition of the active power (2) the first magnitude of the equivalent conductance G_{T1} (1) can be calculated just at the end of period T_1 . Nevertheless, within the period the load converts energy. If assuming the initial magnitude of the conductance to be zero the supply source does not provide energy to the load. The active filter does by providing the energy W_{AF} :

$$\int_0^t \{p_L(\tau) + p_{AF}(\tau)\} d\tau = W_{AF0} - w_{AF}(t), \quad (3)$$

$$t \in (0, T_1), \quad w_{AF}(t=0) = W_{AF0},$$

where: W_{AF0} is filter initial energy, $w_{AF}(t)$ is filter energy at time t , p_L and p_{AF} are load and filter instantaneous powers.

The filter energy $w_{AF}(t)$ tracks the active energy consumed/stored/generated in the load, and dissipated in filter switches during period T_1 .

Then an instantaneous equivalent conductance $g(t)$ may be introduced:

$$g(t) = \frac{W_{AF0} - w_{AF}(t)}{TU_S^2}. \quad (4)$$

The conductance varies in time. Using (4) the active current reference (1) may be distorted even if the supply voltage u_S is of ideal shape. Therefore the current reference could not be considered as active current. To maintain the active current in proportion with the voltage the magnitude of the equivalent conductance should be constant within each time period T . Therefore the G_0 is zero within the period T_1 , and the first magnitude of the “real” equivalent conductance G_{T1} , which is used to charge the supply source, is recorded exactly at instant $t = T_1$:

$$G_{T1} = g(T_1) = \frac{W_{AF0} - w_{AF}(T_1)}{TU_S^2}. \quad (5)$$

The total change of active filter energy during the period T_1 may be expressed as:

$$(P_{L,T1} + P_{APF,T1})T = W_{AF,T1} - W_{AF0} = \Delta W_{AF,(0-T1)},$$

where W_{AF, T_1} is filter energy at the end of the first period of load work, P_{L, T_1} and P_{AF, T_1} are load and active filter active powers in the period T_1 .

As a summary: taking into account that the initial magnitude of the equivalent conductance G_0 is assumed to be zero, the first **calculated** equivalent conductance G_{T_1} is equal to the first conductance **change**:

$$G_{T_1} = \Delta G_{T_1} = \frac{P_{L, T_1} + P_{AF, T_1}}{U_S^2} = \frac{W_{AF, 0} - W_{AF, T_1}}{TU_S^2}. \quad (6)$$

Applicability of Equations (1)-(6) is not restricted to certain kind of circuit, and can be easily implemented into *DC* or *AC* single- multiphase circuits, as is described in Section 3.

D) Quality of reference signal of active current waveform

It is well known that voltage and current harmonics interacting with each other carry active power (7):

$$P_h = \sum_{n=2}^{\infty} U_n I_n \cos \varphi_n. \quad (7)$$

Using directly the equivalent conductance (6) we cannot distinguish between the fundamental and harmonic active powers. Energy of higher harmonics impacts energy stored in the filter. This amount of energy influences the information on the load active power and increases amplitude of the reference active current signal. Additionally, the reference current waveform depends on the shape of supply voltage (1) and may be distorted.

However, such effect can be cancelled by use of the voltage source fundamental frequency component u_{1S} instead of the distorted signal u_S . For the same reason voltage in the denominator of the expression (1) may be considered as U_{1S}^2 instead of U_S^2 . Such appropriate voltage signal may be obtained in many ways [18, 22].

E) Example 1

The filter energy is sampled at the very end of each supply source cycle. During the first period T_1 of the load work (Fig. 2 and 3, 40 ms-60 ms,) the filter fully supplies the load, i.e. the filter provides active and non-active currents simultaneously. Therefore, the filter acts with greatest power during the period T_1 . The first equivalent conductance is calculated at the end of this period (Fig. 3). The conductance is applied for the next period T_2 . From this period on the filter stops supplying the load and starts compensating the non-active current. The supply source current is being shaped by the filter to be only active: $i_{S(T_2-T_6)} = G_{T_1} u_{S1}$.

Due to the time-variable load (i.e. presence of load non-active current) the filter energy varies as well as instantaneous conductance (4), (Fig. 3, time period 60 ms-160 ms). As the filter's energy is sampled, and, as a result, these changes are filtered, these variations cannot influence the supply source current.

After switching off the load at $t = 160$ ms the source current flows for one period T . In a sense the source pays off its energy debt from the period T_1 . The filter is automatically ready for the next compensation.

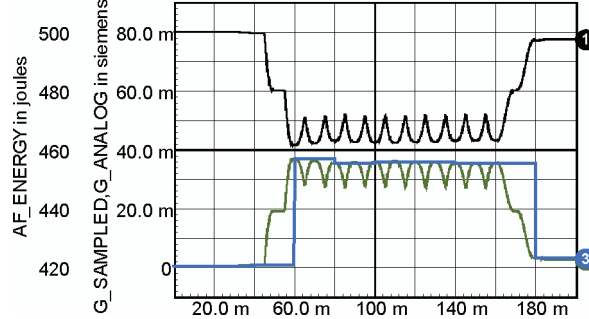

Fig. 3. Determining equivalent conductance. Filter energy (waveform 1), instantaneous conductance $g(t)$ (“reversed” waveform 1), and sampled conductance G_{Tn} (“rectangular” waveform 3)

F) Asynchronous start of filter action

It does not matter whether the filter is switched-on when the load is already working or vice versa. Moreover, it does not matter if the switch-on moment hits the beginning of the supply source cycle or is delayed for time t^d , $0 < t^d < T_1$. In such a delay the first equivalent conductance G_{T1} may be calculated as too small. In this case the source active current may be too small to fully supply the load active energy during the period T_2 :

$$i_{p,T2}^d = G_{T1}^d u_S \leq i_{p,T2}. \quad (8)$$

Controlling supply source current to be equal to $i_{p,T2}^d$ the filter decreases its energy:

$$\Delta W_{AF,T2} = \int_0^T (i_{p,T2}^d - i_{p,T2}) u_S dt. \quad (9)$$

The calculated equivalent conductance increases during the period T_2 :

$$G_{T2} = G_{T1}^d + \Delta G_{T2}, \quad (10)$$

where:

$$\Delta G_{T2} = -\frac{\Delta W_{AF,T2}}{TU_S^2}. \quad (11)$$

As a consequence during the next period T_3 the source fully supplies the load.

G) Case of variable load power

When the load active power varies from one period T to another, the relation between filter’s energy and the equivalent conductance is still clear. Due to sampling the conductance always at the end of each period T , the calculated conductance signal – used to produce the active current reference – cannot change within any period T . Therefore, each variation of load

active power changes energy stored in the filter and changes magnitudes of samples of the equivalent conductance signal:

$$\Delta G_{Tn} = \frac{\Delta P_{L,Tn} + \Delta P_{AF,Tn}}{U_S^2} = -\frac{\Delta W_{AF,Tn}}{TU_S^2}. \quad (12)$$

As a result, the total change of filter energy may be considered as a sum of successive in-period changes. The summing begins from the initial conductance G_0 , up to the $(n-1)$ th one. The conductance actually used, in the n -th T , to create the active current signal equivalent conductance G_{Tn}^a , may be calculated on the basis of the sum of partial changes:

$$G_{Tn}^a = G_0 + \Delta G_{T1} + \Delta G_{T2} + \dots + \Delta G_{T(n-1)}. \quad (13)$$

It is worth to notice that the actual for n -th period T conductance G_{Tn}^a does not have any relation with active power during this period. The actual conductance is a prediction which may be fulfilled or not.

On the other hand, the total change of energy stored in the filter after $(n-1)$ periods T may be considered as a “single-step” process:

$$\Delta W_{AF} = W_{AF, T(n-1)} - W_{AF0}, \quad (14)$$

where $W_{AF, T(n-1)}$ is filter's energy after $(n-1)$ periods T .

Thus, the conductance and the active current for n -th period T_n can be determined directly on the basis of energy measured at the end of the $(n-1)$ -th period:

$$G_{Tn}^a = -\frac{\Delta W_{AF}}{TU_S^2} = \frac{W_{AF0} - W_{AF, T(n-1)}}{TU_S^2}. \quad (15)$$

3. Filter structures

A. Introduction

Figure 4 presents the general structure of the considered active filter. The signals measured and processed are as follows: source voltage u_s , source current i_s , filter current i_F and filter's capacitor voltage U_C . The signals of filter's inductor current i_F and capacitor voltage are processed to obtain the equivalent conductance G signal using the *Load Conductance Computing* block. The product of the conductance and source voltage constitutes the active current reference, which is then compared with the source current. The resulting error signal is utilized for shaping the source current to be active.

There are converters which may be controlled using the structure shown above. Some of them are referred below and the way of obtaining the equivalent conductance is briefly described.

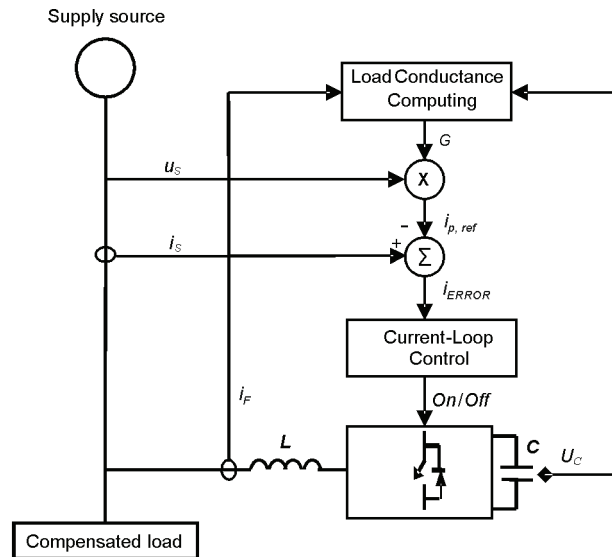

Fig. 4. General operational structure of considered shunt active filter

B) Full-bridge active filter

For all filter structures presented below the filter current is generated using the same method. The method can be shortly described on the base of full-bridge structure: The filter current is forced dynamically by the action of filter's switches PA , PB , NA , NB which are shown in Figure 5. The switches change the voltage direction across the filter's reactor L . This allows influencing the source current:

$$\frac{di_s}{dt} = \frac{u_s + \sigma u_c}{L} + \frac{di_{Ls}}{dt}, \quad \sigma = \pm 1. \quad (16)$$

In the paper the coefficient σ is controlled to apply full filter capacitor voltage accordingly or oppositely to the supply voltage u_s . However, the control method may be extended to the three-state control, $\sigma = (1, 0, -1)$, to reduce power dissipated in filter switches [31].

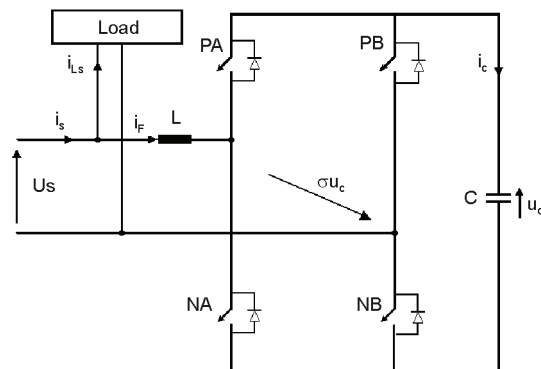

Fig. 5. Power circuit of compensating system with full-bridge voltage source inverter APF

Initial filter energy is equal to:

$$W_{AF0} = \frac{CU_{C0}^2 + LI_{F0}^2}{2}. \quad (17)$$

Filter energy after $(n - 1)$ periods T is equal to:

$$W_{AF,T(n-1)} = \frac{CU_{C,T(n-1)}^2 + LI_{F,T(n-1)}^2}{2}. \quad (18)$$

Then, equation (17) may be rewritten as:

$$G_{Tn}^a = \frac{C(U_{C0}^2 - U_{C,T(n-1)}^2) + L(I_{F0}^2 - I_{F,T(n-1)}^2)}{2TU_S^2}. \quad (19)$$

On the base of Equation (19) the process of reference current obtaining may be considered as shown in Figure 6 below. The Figure 6 complements the Figure 4. The current and voltage signals are the same as shown in Figure 4. On the figure the *sync* block recognizes the end-point of each period T and then generates synchronizing pulses. The *S/H* block latches the instantaneous conductance signal $g(t)$, (4), and holds it as G_{Tn}^a till the next synchronization pulse.

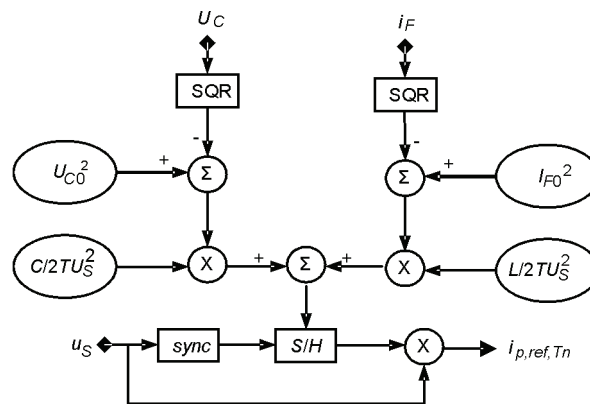

Fig. 6. The reference current obtaining scheme

Finally, the reference for the active current is determined by:

$$i_{p,Tn} = G_{Tn}^a u_{1S}. \quad (20)$$

An appropriate example is shown below in Figures 7 and 8. Figure 7 presents load and source currents. The RMS of the source current is less for about 14% than the load one during corresponding time period.

Figure 8 complements Figure 7. It presents filter capacitor voltage and filter current. The load current is the same as in Figure 7. It can be seen that the filter's capacitor compensates

the load non-active power and buffers changes of the active power. The second feature is important and is considered in Section 5 and 6.

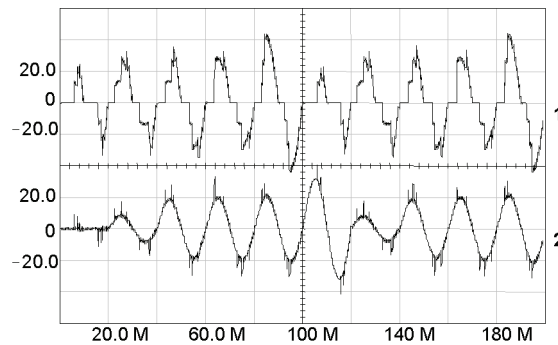

Fig. 7. Load and source currents. *RMS* of load current (waveform 1) for $t \in (0-100 \text{ ms})$ is 17.7 A. *RMS* of source current (waveform 2) for $t \in (20 \text{ ms}-120 \text{ ms})$ is reduced to 15.3 A

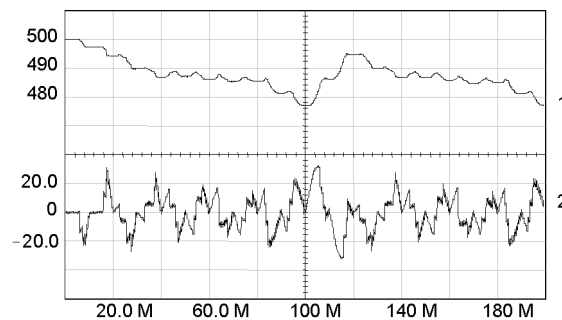

Fig. 8. Filter capacitor voltage (waveform 1), and active filter current (waveform 2, *RMS* in $t \in (20 \text{ ms}-120 \text{ ms})$ is 12.6 A)

C) Current source active filter

The filter may be charged not only with a “static” kind of electric energy, but also with the “kinetic” one, when a reactor is applied as the energy container. Applying high temperature superconductive materials may significantly improve properties of this kind of filter in future. The appropriate filter’s structure is shown in Figure 9.

If the energy stored in C_F is skipped, the active current is:

$$i_{p,T(n)} = G_{Tn}^a u_{1S} = \frac{L(I_{LF0}^2 - I_{LF,T(n-1)}^2)}{2TU_{1S}^2} u_{1S}, \quad (21)$$

where: I_{LF0} initial filter reactor current; $I_{LF,T(n-1)}$ reactor current at the end of $(n-1)$ -th period.

The initial current of filter inductor (initial filter’s energy) is chosen, intentionally, as too low (Fig. 10). The magnitude of the current is not enough to fully supply the load during the first period of the filter action (0-20 ms).

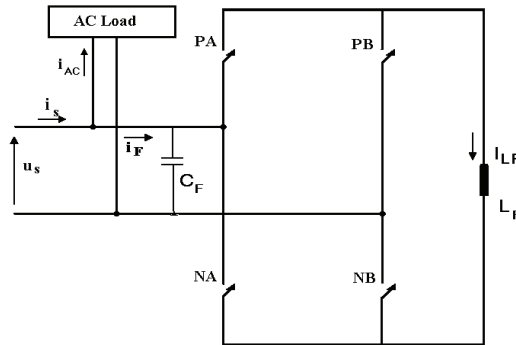

Fig. 9. Power circuit of compensating system with current source active filter

The difference between the load and filter powers must be delivered by the source, so the first calculation of the equivalent conductance is wrong. The appropriate correction of the conductance has to be executed during the next period. Then, starting from the beginning of the third period, the conductance is calculated properly and the source-load-filter circuit achieves steady-state.

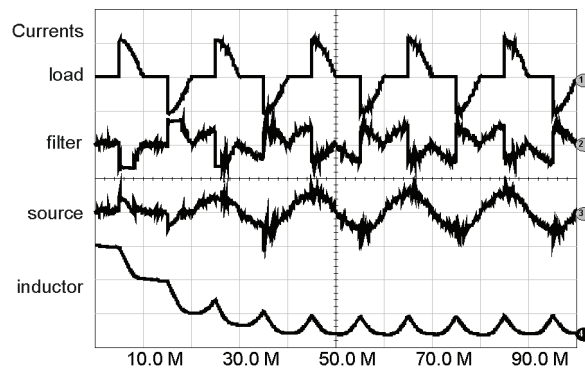

Fig. 10. Current source active filter action. Load (1), filter (2), source (3) currents – 15 A/div, and filter (4) inductor current – starting at 10 A, 0.1 A/div

D) Three-phase active filter

The filter forces active currents evenly through the source phases (23) and in that way also compensates the load asymmetry. This three-phase filter's structure is shown in Figure 11.

The actual equivalent conductance for n -th period T consists of four components, and may be written as:

$$G_{T(n)}^a = G_{W(C), T(n-1)} + G_{W(LFA), T(n-1)} + G_{W(LFB), T(n-1)} + G_{W(LFC), T(n-1)} \quad (22)$$

Energy stored in the reactors is more significant here than in the single-phase filter, because of non-zero currents in at least two phases in the moments of adjusting the conductance.

The per-phase active current signals are determined by:

$$i_{p(k),T(n)} = \frac{G_{Tn}^a}{3} u_{1S(k)} = \frac{C(U\hat{c}_0^2 - U\hat{c}_{,T(n-1)}^2) - LI\hat{L}_{(k),T(n-1)}^2}{6TU_{1S}^2} u_{1S(k)}, \quad (23)$$

where $L = L_{FA} = L_{FB} = L_{FC}$, $k = A, B, C$.

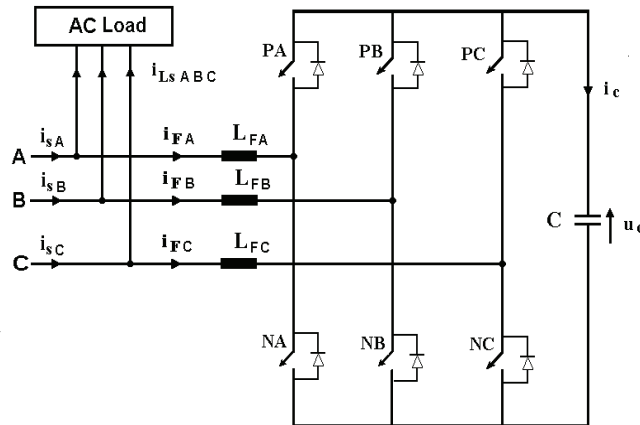

Fig. 11. Power circuit of compensating system with three-phase active filter

Figure 12 shows load phase currents (waveforms 1, 2, 3) and then source phase currents (waveforms 1, 2, 3 respectively) for the first, and then for a few subsequent T_n periods.

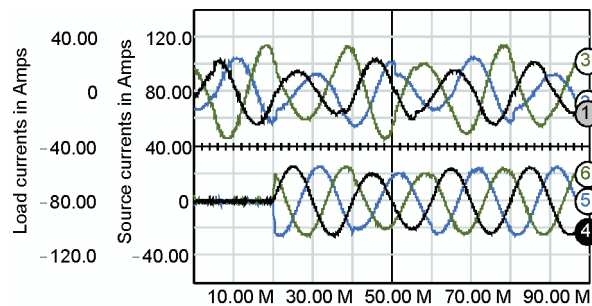

Fig. 12. Load and source currents. *RMS* of load currents for $0 < t < 60$ ms: 13.9 A, 14.1 A and 20.8 A (waveforms 1, 2, 3). *RMS* of source currents for 20 ms $< t < 80$ ms: 16.3 A, 16.3 A and 16.2 A (waveforms 4, 5, 6)

E) Active filtering in DC circuit

The presented control method may be applied in a *AC* circuit as well as in a *DC* one. Let us consider an elementary circuit: an ideal *DC* voltage source and a varying load. A constant period T may be designated for the circuit. Within any n -th period T_n the active power P_{Tn} of

the load is:

$$P_{Tn} = \frac{1}{T} \int_{nT}^{(n+1)T} U_{0S} i_L dt = U_{0S} I_{AV, Tn}, \quad (24)$$

where: U_{0S} is the source voltage; i_L is the load current; and $I_{AV, Tn}$ is the load average current within period T_n .

The active current component may be defined similarly to AC circuit as follows:

$$i_{p, Tn} = G_{Tn}^a U_{0S} = \frac{P_{Tn}}{U_{0S}} = I_{AV, Tn} \quad (25)$$

where actual equivalent conductance is computed as:

$$G_{Tn}^a = \frac{C(U_{C0}^2 - U_{C, T(n-1)}^2) - LI_{L, T(n-1)}^2}{2TU_{0S}^2} \quad (26)$$

The filter structures may be the same as shown in Figures 4-6 and 9. Circuit currents are presented in Figure 13.

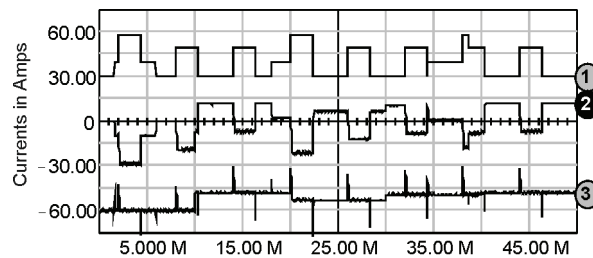

Fig. 13. DC active filter action. Load current (waveform 1), filter current (waveform 2) and source current (waveform 3) – for all 15 A/div

4. Filter energy supplementation

Active filter energy is used for shaping the supply source current to be active and, simultaneously, for „sensing” the equivalent conductance. Changes of filter energy are necessary to obtain equivalent conductance signal, but on the other hand the changes are unfavourable because:

- active power of the compensated load is limited, because filter energy must be considerably higher than the compensated load work during any period T ;
- dynamic properties of the filter depends on “density” (joule/farad or joule/henr) of filter energy.

An additional memory circuit M may be provided to the filter in order to reduce these inconveniences [30]. The operation principle of the circuit is based on memorizing successive changes of the equivalent conductance as follows:

$$G_{Tn}^a = M_{Tn} = G_{T(n-1)} + \Delta G_{T(n-1)}, \quad (27)$$

where $M_{T0} = 0$.

When the memory circuit is used, the filter energy container does not have to perform the task of indicating existing load active power and then the filter energy can be supplemented from the supply source. This happens due to the fact that filter control circuit doubles the supply source current change in the next T period each time after the load active power has changed.

In the next T_{OFF+1} period after switching the load out of operation, the active filter receives energy from the source (Figs. 2, 3). However, taking into account (6) and (27), during T_{OFF+2} the filter gives back “the additional” amount of energy (drawn before to supplement filter energy) to the source. During the last period T of filter operation the equivalent conductance becomes negative:

$$G_{T(OFF+2)} = -G_{T(OFF+1)} < 0. \quad (28)$$

Such effect is unfavorable because flow of excessive amount of energy between supply source and the filter. Active filter energy and source current when the memory circuit is applied is shown in Figure 14.

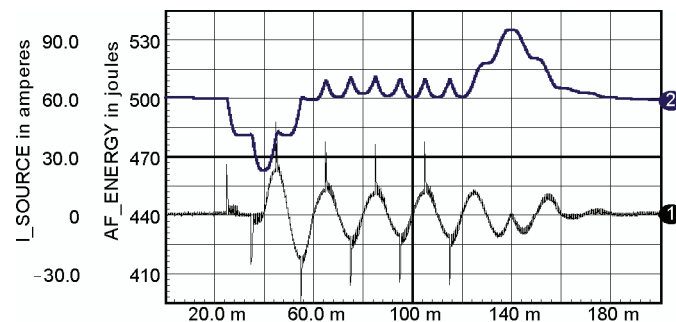

Fig. 14. Filter energy supplementation. Filter energy and source current

Supplementing the capacitor voltage may be also useful when the filter does not only compensate non-active current of load, but is also used as a rectifier for a DC load, which may be connected in parallel to the filter capacitor C . The control method is the same for the “pure” filter and for the filter/rectifier. Therefore such type of rectifier can act with high power factor.

5. Energy flow buffering – introduction

A) Buffering the load energy changes

The presented shunt active filter does not only compensate the non-active current. It also takes part in transferring active energy from the supply source to the load. Each change of load active power implies change of energy W_{AF} stored in the active filter.

From (15) and (20) one can see that the active filter takes over each change of energy flowing from the supplying source to the load – each change of load active power is buffered by adequate change of energy stored in the filter. Thus the active filter can be controlled to regulate the energy flow between the source and the compensated load. The filter properties which may be used to the power flow control are considered in the following sections.

B) Control coefficients adjustment

The Equations (19), (23) and (26) may be rewritten as:

$$G_{Tn}^a = K_u \theta_u - K_i \theta_i, \quad (29)$$

where:

$$K_u = \frac{C}{2TU_{1s}^2} \quad \text{or for three-phase filter: } K_u = \frac{C}{6TU_{1s}^2}, \quad (30)$$

$$K_i = \frac{L}{2TU_{1s}^2} \quad \text{or for three-phase filter: } K_i = \frac{L}{6TU_{1s}^2}, \quad (31)$$

$$\theta_u = U_{C0}^2 - U_{C,T(n-1)}^2, \quad (32)$$

$$\theta_i = I_{L,T(n-1)}^2. \quad (33)$$

The actual magnitude of the load equivalent conductance signal depends on constant coefficients K_u and K_i and variable voltage and current dependent factors θ_u and θ_i . The conductance is determined with the assumption that the active filter balances every change of load power within each individually observed single period T_n . In such a case the source power reaches steady state in a single period T .

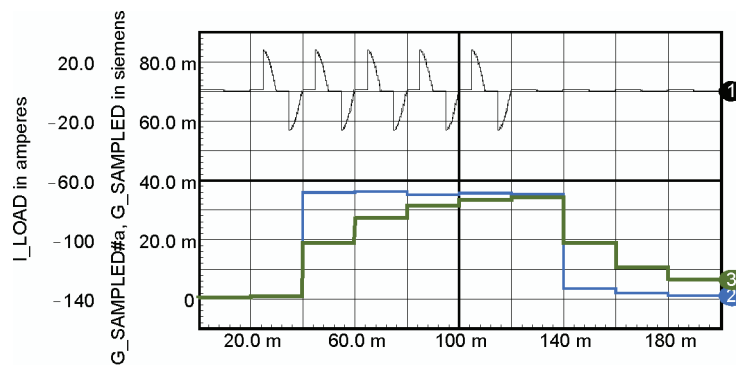

Fig. 15. Inertial filter response. Load current (waveform 1), equivalent conductance for nominal K_u (waveform 2) and $K_u^a = 0.5K_u$ (waveform 3)

However, the filter action may be controlled to be inertial when changes of the equivalent conductance signal are reduced. Each load active power change may then begin changing of

the equivalent conductance signal in a geometric sequence. Such scenario may be realized when the coefficient K_u^a applied is smaller than the one calculated in (30): $K_u^a < K_u$, Figure 14. The coefficient K_i is useless for this purpose because despite coefficients K_i and K_u are of the same magnitude, the product $K_i \theta_i$ is much smaller than the product $K_u \theta_u$.

After each load power change the source power approaches the steady-state in a few T periods, step-by-step. If within these several steps the load power changes in the opposite direction, the filter buffers flow of the active energy and in that way stabilizes supply source power. It should be noticed, that applying diminished coefficient K_u^a forces the filter to operate with lowered filter energy. This effect diminishes the filter's ability to compensate sudden changes of load power.

C) Filter self-regulation

The filter may be controlled by the use of a self-regulation algorithm. The algorithm regulates the coefficient of the equivalent conductance signal reduction. When the reduction coefficient increases, the source operates in a stable way even if the load power varies. However, in the same time the energy stored in the filter decreases. Such an effect lowers the filter dynamics. Therefore, if the load power does not vary in some following periods, the reduction coefficient should be diminished [31].

6. Averaging of supply source power

There is an eventuality of reversing active energy flow when the load contains a source of energy. In such case the load equivalent conductance becomes negative, and the active filter should reverse the source current (1). However, the source current reversing or not depends on the filter control strategy: there is the possibility of transmitting the energy immediately to the source (*transmitting-mode*), or storing it in the filter (*storing-mode*).

A) Active load compensation/buffering, transmitting-mode

When the compensated load is active the transmitting-mode may appear naturally as a consequence of (1). Figure 16 shows a load (load current: waveform 2) which acts as a half-wave rectifier (0-60 ms), half-wave shifted-phase supplier (60 ms-140 ms) and half-rectifier again (140 ms-200 ms). The proper active filter's work is presented on waveform 3. Non-active current is compensated for passive as well as for active load work. When the load is active the energy is transmitted to the source (80 ms-160 ms).

Figure 17 complements Figure 16. When the load emits energy the voltage across the filter capacitor raises and the signal of load equivalent conductance, waveform 2, becomes negative. The active energy flows from the load to the source.

B) Active load compensation/buffering, storing-mode

This kind of filter operation is shown in Figure 18. During the first period of time (0-60 ms) the load operates as the half-wave rectifier (load current: waveform 2). The active filter performs compensation of non-active current and the source current is sinusoidal (waveform 3).

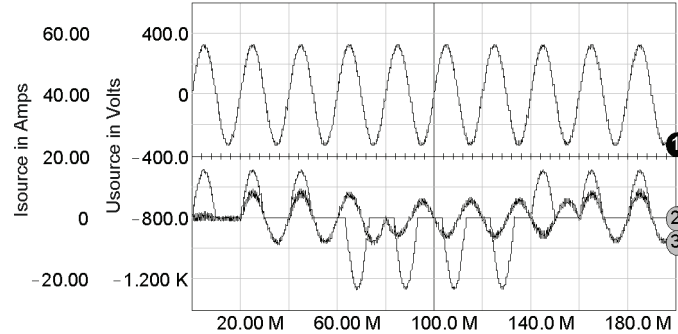

Fig. 16. Source voltage (waveform 1), load current (waveform 2) and source current (waveform 3). Filter acts in transmitting-mode

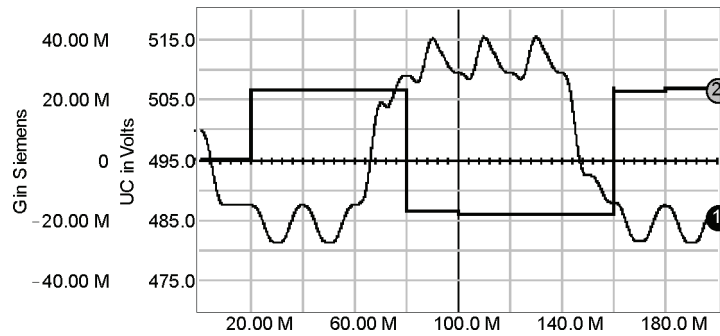

Fig. 17. Filter capacitor voltage (waveform 1) and equivalent conductance (waveform 2). Filter acts in transmitting-mode

Then the load becomes active (60 ms-160 ms) and acts as half-wave shifted-phase supplier. All the energy emitted by load is accumulated in filter's capacitor, waveform 4, the source current does not flow. Starting at $t = 160$ ms the load becomes passive, but the source does not provide energy – the filter does. The source undertakes supplying at $t = 240$ ms, when the filter gave the accumulated energy back and the equivalent conductance signal goes positive. In this way the active filter acts simultaneously as a local energy accumulator.

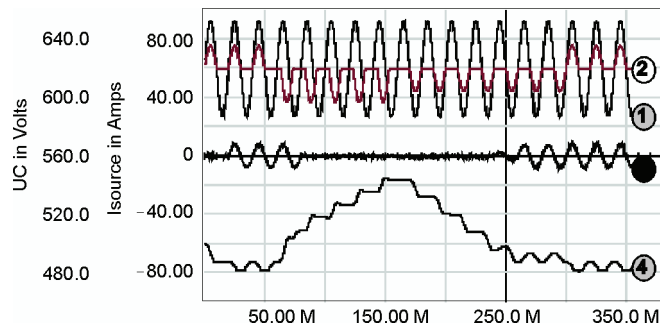

Fig. 18. Source voltage (waveform 1), load current (waveform 2), source current (waveform 3) and filter capacitor voltage (waveform 4). Filter acts in storing-mode

C) Complex three-phase passive load compensation/buffering

The next example, Figures 19-21, shows compensation of two three-phase three-wire loads working in parallel. The first load consists of balanced three resistors in Y connection. The second load consists of three current sources in Δ connection, which operate with diverse amplitudes and frequencies: 5A/60 Hz, 10 A/70 Hz and 15 A/90 Hz. For time period 0-160 ms the *RMS* of total phase currents of both loads are 15 A in phase A, 12.6 A in phase B and 15.6 A in phase C. The currents of the two loads are shown separately in Figure 19.

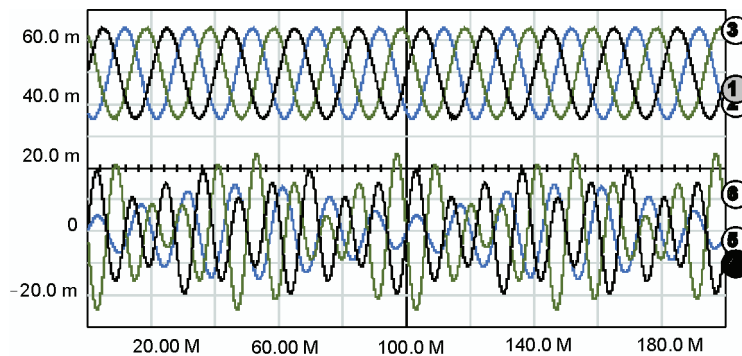

Fig. 19. Resistive load phase currents (waveforms 1, 2 and 3) and phase currents of load consists of current sources (waveforms 4, 5 and 6). The Y scale 10 A/div for all waveforms

Figure 20 presents source currents and filter capacitor voltage. The currents are sinusoidal, balanced and in-phase with source voltages within each individually considered period T . Each phase current has the same 11.1 A multi-period value (20 ms-180 ms). The coefficient K_u is nominal (30).

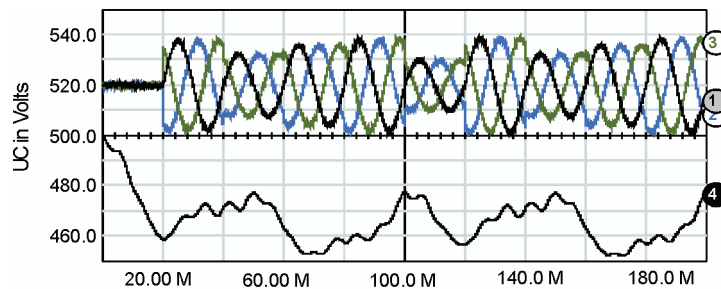

Fig. 20. Source phase currents (waveforms 1, 2 and 3) and filter's capacitor voltage. Coefficient K_u is nominal. The Y scale for currents is 10 A/div

Because of load power variation the amplitude of source currents change from one period T to another. Using the inertial filter control (Fig. 15) the multi-period *RMS* of source currents may be diminished and source active power may be stabilized. Figure 21 presents the effect of decreasing the coefficient K_u (30) to 60% of its nominal magnitude. Phase current *RMS* is lowered to 9.4 A (20 ms-180 ms). Unfortunately, at the same time the filter operates with

lowered capacitor voltage. This inconvenience may be weakened using filter energy supplementation, Figure 14 and relation (27), or the K_u regulation algorithm [31].

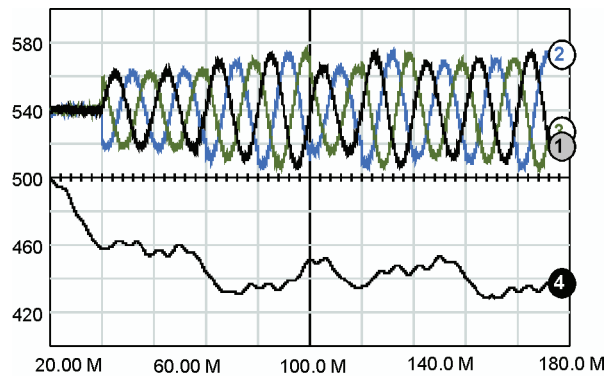

Fig. 21. Source phase currents (waveforms 1, 2 and 3) and filter's capacitor voltage. Coefficient K_u is reduced. The Y scale for currents is 10 A/div

D) Complex three-phase active load compensation/buffering

The next two Figures, 22 and 23, show compensation of two three-phase three-wire loads working in parallel, like in section C, but this time the active power of the resistive load is six times lower. As a result in some time periods the whole load becomes active. The filter's capacitor stores the "excessive" energy and its voltage rises above its initial magnitude – Figure 22, waveform 4, 30 ms-55 ms and 95 ms-155 ms. When the filter's capacitor voltage is higher than the initial voltage the "from the load" recuperated energy may be stored in the filter capacitor and then re-transmitted to the load (filter storing-mode) or transmitted to the source (filter transmitting-mode).

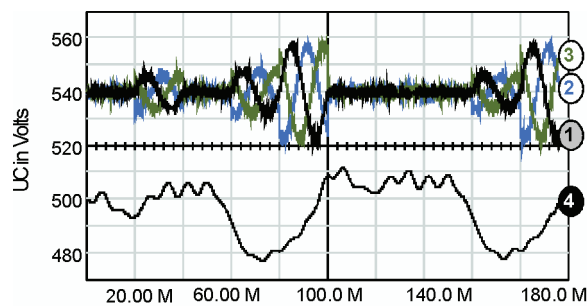

Fig. 22. Source phase currents (waveforms 1, 2 and 3) and filter's capacitor voltage. The Y scale for currents is 5 A/div. The K_u is nominal. Filter acts in storing-mode

In the Figure 22 (above) the filter acts in storing-mode. During time periods 40 ms-60 ms and 100 ms-160 ms the load is supplied by the filter. Energetic-wise the source is not engaged. However, the source works in a "pulsing" way: current waveforms 1, 2 and 3. The phase A RMS current is 3 A during time period 0-200 ms. There is the possibility of lowering the

current applying the modified coefficient K_u . The effect of lowering the coefficient to 20% of its nominal magnitude is presented in Figure 23. The phase A RMS current is decreased to 1.5 A.

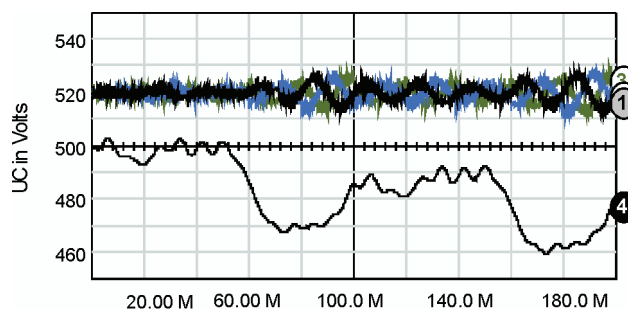

Fig. 23. Source phase currents (waveforms 1, 2 and 3) and filter's capacitor voltage. The Y scale for currents is 5 A/div. The K_u is lowered. Filter acts in storing-mode

When the filter operates in the storing-mode the load is buffered effectively, Figure 23. The “from load” energy is then redistributed without engaging the supply source.

7. Conclusion

The distinctive feature of the presented control method is that certain changes of energy stored in the active filter are utilized as the fundamental source of information concerning the active current and the power of the compensated load. Filter energy changes are obtained by monitoring voltages and currents in filter's reactances. Such monitoring is easy to perform. The filter energy may be also used to stabilize the supply source power by controlling the flow of active and non-active energies in the circuit. Such a possibility may be considered in two aspects: for passive and for active load. In both cases the active filter can buffer the load and in that way average changes of the supply source power, lowering the electric generation and transmission system and contributing to energy saves.

References

- [1] Abdeslam D., Wira P., Merckle J. et al., *A unified artificial neural network architecture for active power filters*. IEEE Trans. Ind. Electron. 54(1): 61-47 (2007).
- [2] Akagi, H., *Active harmonic filters*. Proc. of the IEEE 93(12): 2128-2141 (2005).
- [3] Aredes M., Haefner J., Heumann K., , *Three-phase four-wire shunt active filter control strategies*. IEEE Trans. Power Electron. 12(2): 311-8 (1997).
- [4] Chiang S.J., Ai W.J., Lin F.J., *Parallel operation of capacity-limited three-phase four-wire active power filters*. IEE Proc. Electr. Power Appl. 149(5): 329-36 (2002).
- [5] Czarnecki L.S., Budeanu and Fryze: *Two frameworks for interpreting power properties of circuits with nonsinusoidal voltages and currents*. Arch. fur Elektrot. 80(6): 359-67 (1997).
- [6] Depenbrock M., *The FDB-method, a generalized applicable tool for analyzing power relations*. IEEE Trans. on Power Delivery 8(2): 381-7 (1993).

- [7] Depenbrock M., Staudt V., *The FBD-method as tool for compensating total non-active currents*. 8th Int. Conf. on Harm. and Qual. of Power 1: 320-4 (1998).
- [8] Depenbrock M., Staudt V., *Stability problems if three-phase systems with bidirectional energy flow are compensated using the FDB-method*. Proc. of 8th ICHQP, pp. 325-30 (1998).
- [9] El-Habrouk M., Darwish M.K., Mehta P., *Active power filters: a review*. IEE Proc. Electr. Power Appl. 147(5): 403-13 (2000).
- [10] Fryze S., *Wirk-, Blind-, und Scheinleistung in Elektrischen Stromkreisen mit nichtsinusformigem Verlauf von Strom und Spannung*. ETZ 53: 596-9, 625-7, 700-2 (1932).
- [11] Strzelecki R., Wojciechowski M., *New Control System of the Shunt Active Power Filter*. Int. School on Nonsinus. Currents and Compensation, Łagów, Poland (2008).
- [12] Habetler T., Harley R., *Power electronic converter and system control*. Proc. of the IEEE 89(6): 913-25 (2001).
- [13] Strzelecki R., Wojciechowski M., *Power flow in typical series-parallel hybrid filters topologies*. PQ2008: 6th International Conference, Pärnu, Estonia (2008).
- [14] Hassenzahl W., Hazelton D., Johnson B. et al., *Electric power applications of superconductivity*. Proc. of the IEEE 92(10): 1655-74 (2004).
- [15] Jain S.K., Agrawal P., Gupta H.O., *Fuzzy logic controlled shunt active power filter for power quality improvement*. IEE Proc. Electr. Power Appl 149(5): 317-28 (2002).
- [16] Strzelecki R., Benysek G., Jarnut M., Kot E., *Voltage source power line conditioners*. JUEE. 10(1/2): 13-24 (2004).
- [17] Komurcugil H., Kukrer O., *A new control strategy for single-phase shunt active power filters using a Lyapunov function*. IEEE Trans. Ind. Electron. 53(1): 305-12 (2006).
- [18] Kunjumammed L., Mishra M., *A control algorithm for single-phase active power filter under non-stiff voltage source*. IEEE Trans. Power Electron. 21(3): 822-5 (2006).
- [19] Lin B., Huang C., *Implementation of a three-phase capacitor-clamped active power filter under unbalanced condition*. IEEE Trans. Ind. Electron. 53(5): 43-52 (2006).
- [20] Lin B-R., Lee Y-C., *Three-phase power quality compensator under the unbalanced sources and nonlinear loads*. IEEE Trans. Ind. Electron. 51(5): 1009-17 (2004).
- [21] Lin H., *Intelligent neural network-based fast power system harmonic detection*. IEEE Trans. Ind. Electron. 54(1): 43-52 (2007).
- [22] Moreno V., Pigazo A., *Modified FBD method in active power filters to minimize the line current harmonics*. IEEE Trans Power Delivery 22(1) 735-46 (2007).
- [23] Strzelecki R., Benysek G., Jarnut M., *Interconnection of the Customer-Side Resources Using Single Phase VAPF*. 5th Int. Conf-Workshop CPE 2007, Poland, (2007).
- [24] Ortuzar M., Carmi R., Dixon J., Moran L., *Voltage-source active power filter based on multilevel converter and ultracapacitor DC link*. IEEE Trans. Ind. Electron. 53(2): 477-85 (2006).
- [25] Ovaska S., Vainio O., *Evolutionary-programming-based optimization of reduced-rank adaptive filters for reference generation in active power filters*. IEEE Trans. Ind. Electron. 51(4): 910-6 (2004).
- [26] Piróg S., *PWM rectifier and active filter with sliding-mode control*. EPE'97 (1997).
- [27] Ribeiro P., Johnson B., Crow M., Arsoy A., Liu Y., *Energy storage systems for advanced power applications*. Proc. of the IEEE 89(112): 1744-56 (2001).
- [28] Routimo M., Salo M., Tuusa H., *Comparison of voltage-source and current-source shunt active power filters*. IEEE Trans. Power Electron. 22(2): 636-43 (2007).
- [29] Singh B., Al-Haddad K., Chandra A., *A review of active filters for power quality improvement*. IEEE Trans. Ind. Electron. 46(5): 960-71 (1999).
- [30] Szromba A., *A shunt active power filter: development of properties*. COMPEL 23(2): 1146-62 (2004).
- [31] Szromba A., *Synchronized active power filter*. 4th Int. Workshop Compatibility in Power Electronics CPE 2005, pp. 148-65, Gdynia, Poland, (2005).
- [32] Akagi H., Watanabe E., Aredes M., *Instantaneous Power Theory and Applications to Power Conditioning*. Wiley & Sons. (2007).