

Communication issues in the control system of reactive power compensator for hydroelectric plant with induction generator

REMIGIUSZ OLESIŃSKI, PAWEŁ HAŃCZUR,
JANUSZ WIŚNIEWSKI, WŁODZIMIERZ KO CZARA

*Electrical Drive Division, Institute of Control and Industrial Electronics
Warsaw University of Technology
Koszykowa 75, 00-661 Warszawa, Poland
e-mail: {roles/p.hanczur}@isep.pw.edu.pl*

(Received: 03.01.2012, revised: 05.02.2012)

Abstract. The presented paper concerns the issues of communication networks applied to monitoring and control of reactive power compensator for small hydroelectric plants installed in areas distant from urban agglomerations. Ethernet, CAN, Modbus and GPRS transmission protocols has been used. Industrial programmable controller as a data collector has been used also.

Key words: induction generator, reactive power compensation, PLC, SCADA, communication technology

1. Introduction

Modern control systems must present the growing amount of functions and respond to series of demands. It often means combining already existing devices, partial features and parameters of which are desirable. An example of this combination is *Intelligent Compensator of Reactive Power for Small Hydroelectric Plant with Induction Generator* projected and built in Electrical Drive Division of Institute of Control and Power Electronics at Warsaw University of Technology. The main module of this device is a three-level power-electronic converter controlled by the DSP processor. The major role of this unit is to produce reactive power in amount that depends on instantaneous conditions in electrical grid and power given by the hydroelectric generator. In order to provide fully functional operation of the compensator in real electrical system, it should have some additional features. The principal role within these features belongs to communication functions which connect the main module with sensors and actuators, and – which is most important for users and designers – they provide an up-to-date information about state of the compensator and generator and give the possibility to control and change the parameters of the device.

2. Compensator control system

Compensator control system is based on the Texas Instruments TMS320F28335 processor [1]. Its main job is to track measured values of voltages and currents and on this base control the transistor converter to provide proper regulation of capacitive reactive power. Generated reactive power is used to excite the induction generator and assures the proper value of power factor on the plant terminals. The issues of reactive power compensation in small hydroelectric plants are described in papers [2-4].

Fully functional and user friendly system installed in target location even must fulfill some additional requirements even during commissioning tests. Essential of these are the following:

- local human-machine interface for control and visualisation of state of the compensator system;
- cooperation with additional auxiliary devices;
- possibility of remote control of the device.

In order not to burden CPU of the compensator with expanded communication tasks, special architecture has been proposed. Industrial programmable logic controller (PLC) is the central element of the communication system. PLC has the role of the main data collector, relay and sender. The Saia PCD3-M6340 [5] controller and the Saia PG5 Controls Suite 2.0 software package [6] have been used. Projected control and data exchange system is presented in Figure 1. All essential elements of the system mounted in industrial enclosure are presented in Figure 2.

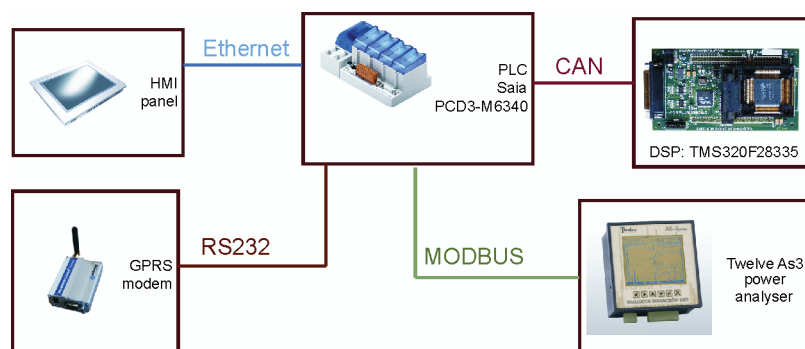

Fig. 1. Schematic of communication connections of the compensator control system

Microprocessor tasks were expanded only by the communication functions to provide one only link with the PLC. Control Area Network (CAN) protocol has been chosen to provide that connection. The PLC apart from CAN interface, is also equipped with MODBUS protocol data link. This interface is often implemented in control&measure devices. In this particular system it is used to connect compensator to power analyser of grid parameters.

Another communication module connected with the PLC is the GSM/GPRS modem. Modem works as the data transmitter in GPRS mode. The link between modem and PLC is realized by the RS232 interface. PLC communicates with modem with use of standard set of

AT commands. The GPRS link is used for the external supervision of compensator and generator via internet.

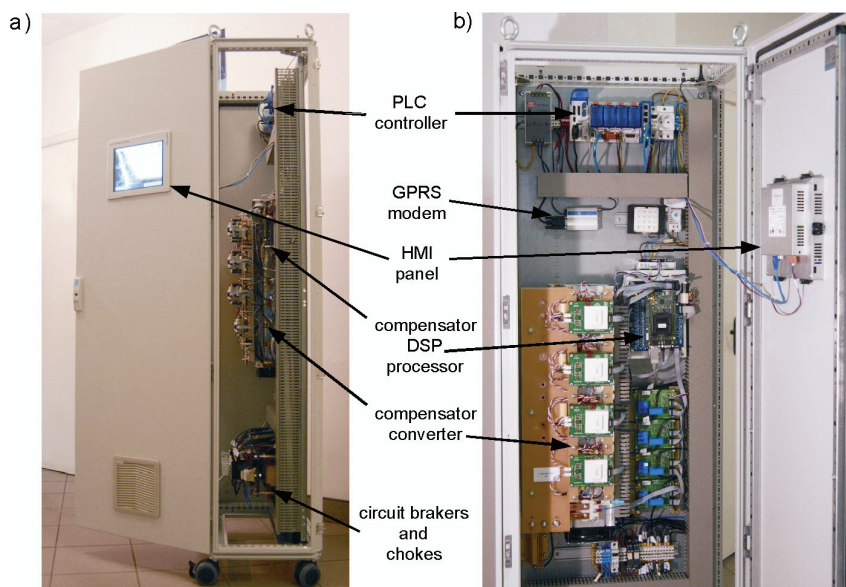

Fig. 2. Elements of the system during mounting: a) compensator enclosure with mounted HMI panel; b) inside view of the compensator enclosure

Industrial HMI (Human Machine Interface) panel plays the role of interface between compensator and local (at power plant) users or servicemen. The HMI is connected to PLC by the local separated ethernet line. Data exchange is based mainly on the http protocol.

3. Device state visualization

HMI panel displays present state of the converter and all instantaneous measured values. It makes possible the supervision of the converter parameters, e.g. current flows, voltages, rotational speed of generator, state of the switches. With number of programmed screens, user gains possibility to change the parameters of converter and generator, reactive power setpoint, capacitor and grid switches position.

The HMI works as a web-panel. Web-panel is a computer with running web-browser displayed on touch-panel. The device has its own ethernet link to communicate with devices around. It has configured IP-address and name of the html file of the server which it will be displaying. The website is located on the PLC which has an additional feature of being a http and ftp server. The www site which is read by the panel from server is written as a java script applet. It is possible to view the visualisation screens using any browser on any PC computer connected to internet (Fig. 3, 4) in the same way but using an external IP address provided by the GPRS link.

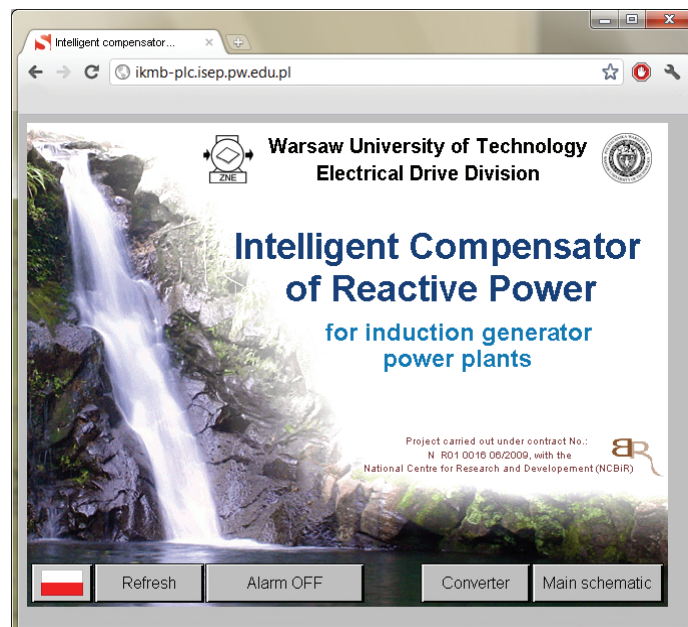

Fig. 3. The window of the web-browser with welcome screen of the water plant compensator displayed

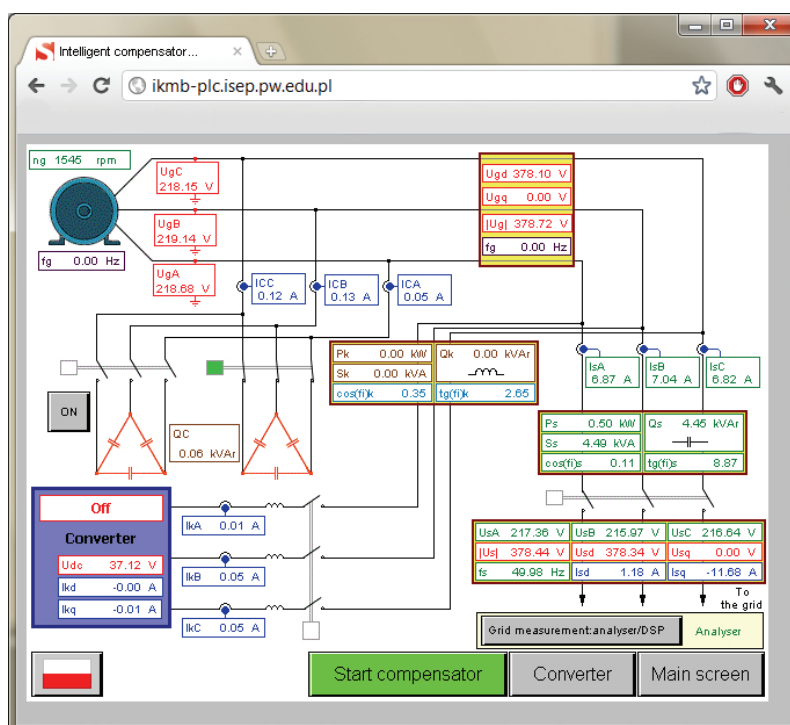

Fig. 4. One of the operator screens showing the state of switches and the most important measured values

All displayed data and all the operations performed on the touch panel, i.e.: clicking on active elements, buttons, changing settings and adjustments have an projection in the internal memory of PLC. Data received in that way, can be then transferred to the converter processor via CAN network.

4. Modbus network

Modbus protocol is an open communication standard which is useful to transfer small packages of data between devices when timing issues are not critical. There is a wide variety of applications of this protocol and it is supported by many device manufacturers. It is commonly used in small distant measurement devices. Data exchange in this protocol is organized in master-slave manner. In this particular system, the PLC plays the role of master of Modbus network. The only slave on in this net is the power analyser. The power analyser is a measurement device which supplies the system with information about active, reactive and apparent power, power factor, currents and voltages in each phase. It's placed between generator-compensator system and grid. It's of course possible to mount equipment such as analyser in other places of the system also connected by modbus network. Figure 5 shows the fragment of programming block which configures parameters of transmission in the master of the modbus network. The slave device is configured correspondingly to the master setup, the setting "Channel 2" stands for second physical port on the controller.

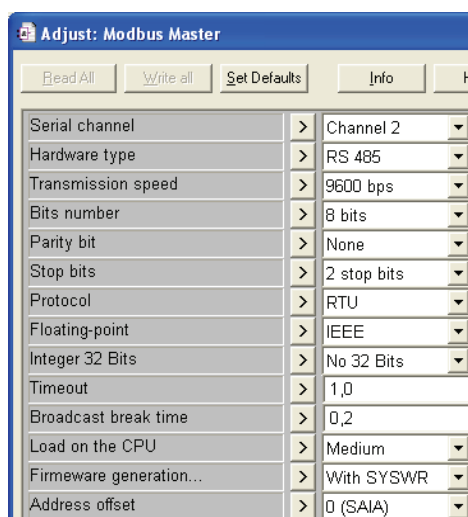

Fig. 5. Software configurator block of Modbus data link

Figure 6 presents additional setup of the modbus link configuring the address of the slave ("Station number 2" – address of the power analyser) and the range of registers to be read from device and put into PLC memory.

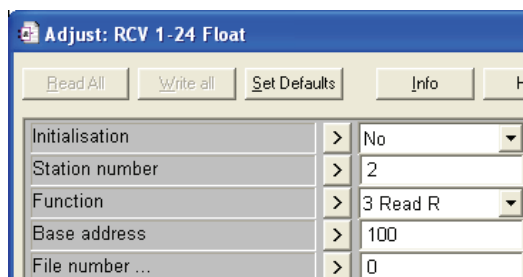

Fig. 6. Modbus registers and slave device address configuration

Figure 7 shows the image of line and phase voltages and one current measured by an analyser and transferred to the controller. These values are then put into specified controller registers. In the same time, the http server reads these registers and updates the corresponding variables in web java applet. Eventually measured data are displayed on touch panel or in the internet browser. There is a possibility to use those values by the converter processor (after transferring it by the CAN network).

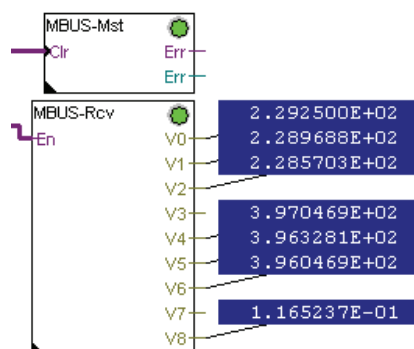

Fig. 7. Section of PLC program which reads the parameters in the power plant and grid connection. First three values are the phase voltages, next three are line voltages, the last one is the current in the first phase

5. GPRS transmission

Compensator and its system is to be installed on small hydroelectric plant of Samogowo in region of Warmia in northern part of Poland. The plant is located distantly from urban facilities and agglomerations. There are no phone lines and wire internet access. Moreover this is a maintenance-free object and (except for circumstances like faults or damages) there are no people working there.

For reasons above and the fact that nearly whole territory of Poland is within GSM coverage, it has been decided to make the supervision link using the mobile phone technology. The PLC has been equipped with the GPRS modem. The SIM card provided by the GSM operator is registered to use a packet data transmission. In this way the data prepared in the controller can be shared and read by remote computers in form of e.g. websites. It is also possible to program and to debug the application on the PLC through this connection.

Figure 8 shows the result of commands “tracert” and “ping” during the connection between computer located in Warsaw at Warsaw University of Technology and a remote host with IP-address 87.251.253.24 which is in fact the PLC placed at destined location. It is visible that the quality of connection is quite high and the connection is very stable – only one packet was lost per over 1100 sent.

a)

```

C:\Users\Renek>tracert 87.251.253.241

Tracert do 87.251.253.241 [87.251.253.241]
z maksymalną liczbą 30 przeskoków:

  0  1 ms  1 ms  2 ms  gate448.isep.pw.edu.pl [10.44.48.1]
  1  <1 ms  1 ms  2 ms  coi-ee.pw.edu.pl [194.29.132.225]
  2  <1 ms  <1 ms  <1 ms  c6503.rtr.pw.edu.pl [194.29.129.50]
  3  * * * * * Upłynął limit czasu żądania.
  4  * * * * * Upłynął limit czasu żądania.
  5  * * * * * Upłynął limit czasu żądania.
  6  * * * * * Upłynął limit czasu żądania.
  7  * * * * * Upłynął limit czasu żądania.
  8  * * * * * Upłynął limit czasu żądania.
  9  * * * * * Upłynął limit czasu żądania.
 10  * * * * * Upłynął limit czasu żądania.
 11  * * * * * Upłynął limit czasu żądania.
 12  * * * * * Upłynął limit czasu żądania.
 13  382 ms  239 ms  459 ms  87.251.253.241 [87.251.253.241]

Tracert zakończony.
C:\Users\Renek>

```

b)

```

C:\Users\Renek>ping 87.251.253.241

Pukoty: Wyślane = 1160, Odebrane = 1159, Utracone = 1 (<0% straty),
Szacunkowy czas brnięcia pakietów w milisekundach:
Minimum = 164 ms, Maksimum = 1690 ms, Czas średni = 263 ms
Control-C
^C
C:\Users\Renek>

```

Fig. 8. The results of “tracert” (a) and “ping” (b) commands executed on a computer located in Warsaw and PLC located in destined location

However, lag time in transferring packages is long and affects the delay while reading the instantaneous values. Maximum used bandwidth resulting from the continuous transmission of data (web pages) in the local ETH link is about 300 kbit/s. When GPRS connection is used, connection speed is several times lower. For this reason, the data timeliness is low – the delay between the actual and the received value reaches a few seconds. Such a link may not be used for time-critical operations.

Another important functionality of the system, enabled by the GPRS link, is the possibility of remote programming of the PLC. In case of necessity to change the program, web interface, debug or reboot the system – software utility allows such operations from any computer connected to the internet. Figure 9 shows the configuration window of online “utility” in situation of a remote connection with the controller located in the facility.

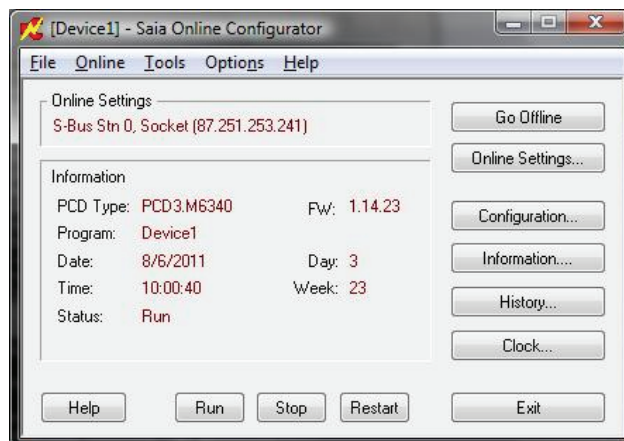

Fig. 9. Online configurator of the PLC controller during communication via a GPRS link

6. CAN bus

CAN bus (Control Area Network) is a network proposed by Bosch company as a communication medium for exchanging data in motor vehicles, e.g. between engine components, fuel injection systems, airbags, ABS system or even radio system. Currently, due to its advantages, this network is used in a number of other applications as fast and reliable medium for exchanging information between different components of devices, also industrial. The project team, assuming the prospect of future use of the compensator not only in small hydropower plants, has chosen this solution as the universal protocol for use in the compensator design.

The main controller of the compensator converter TMS320F28335 processor has a hardware support for CAN2.0 bus which greatly facilitates communication with outside systems. Similarly PCD3-M6340 driver has hardware and software modules to support this protocol. Using the CAN Data Mapping method [8], provided by the PLC, the data exchange protocol between PLC and converter processor has been designed and implemented.

CAN Data Mapping is a method which forms another layer in space of communication protocols involved in CAN implementations. It is placed over the two lowest (fundamental) layers of the ISO/OSI described in CAN bus standard. It is functionally similar to PDO datagrams in CANopen, however, it formally lies between the application layer of the network and the physical layer and data link defined in the specification of CAN2.0.

Implementation of the protocol is made as follows: Cyclically after period of desired time interval PLC sends the content of selected registers from its memory. Each sent register has its own unique identifier, which is a 29-bit ID field in CAN data frame (Fig. 10). Simultaneously, the inverter processor sends its own similarly constructed data packet – each sent value has an assigned identifier. Tables 1 and 2 show some of the linked identifiers and process data for both directions of data transfer i.e. from the processor to the PLC controller and from PLC to the processor.

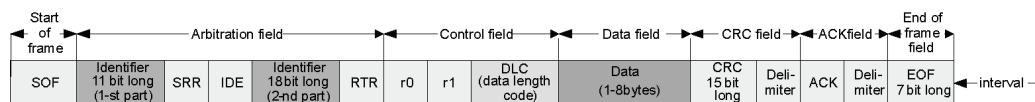

Fig 10. Data frame of CAN2.0B protocol used as a communication medium between PLC and converter processor [8]

The received data frames are analyzed regarding value of the ID field. The content is saved in appropriate memory cells, registers or flags. The links between IDs and memory cells are configured by software in the DSP processor and CAN configuration tool in PLC.

Table 1. Exemplary set of process data sent from PLC to converter processor

ID field value	Number of transmitted bytes (DLC field)	Type of transmitted data	Type conversion before sending	The actual content of the variable	Source: PLC flag or register
100	1	INT (1 byte)	bool → int	state of K1 switch	F100
101	1	INT (1 byte)	bool → int	state of K2 switch	F101
102	1	INT (1 byte)	bool → int	state of K3 switch	F102
...
200	4	FLOAT (4 bytes)	none	rotational speed of generator	R200
201	4	FLOAT (4 bytes)	none	output active power	R201
202	4	FLOAT (4 bytes)	none	output reactive power	R202
...

Table 2. Exemplary set of process data sent from converter processor to PLC

ID field value	Number of transmitted bytes (DLC field)	Type of transmitted data	The actual content of the variable	Destination: PLC flag or register
0	4	FLOAT	Instantaneous voltage at L1 generator phase	R100
1	4	FLOAT	Instantaneous voltage at L2 generator phase	R101
2	4	FLOAT	Instantaneous voltage at L3 generator phase	R102
3	4	FLOAT	Instantaneous voltage at L1 compensator phase	R103
4	4	FLOAT	Instantaneous voltage at L2 compensator phase	R104
...

7. Summary

In the presented control system a large role belong to the set of communication links enabling an implementation of various functions. These connections are both type: local and remote. Due to the nature of individual elements and project requirements, diverse communication networks of various options and parameters have been used. An industrial PLC has been used as a versatile and multi-purpose data collector allowing local devices and remote computers to connect together. This gave an opportunity to check and test the compensator setup not only in the laboratory but in real conditions in distant locations.

Acknowledgments

This paper describes part of a development project No. N R01 0016 06/2009 "Intelligent reactive power compensator for small hydroelectric plants with induction machine" financed by the National Centre for Research and Development (NCBiR), Poland.

References

- [1] <http://www.ti.com/lit/ds/symlink/tms320f28335.pdf>, TMS320F28335, TMS320F28334 TMS320F28332, TMS320F28235, TMS320F28234, TMS320F28232 Digital Signal Controllers (DSCs) Data Manual, accessed June 2011.
- [2] Koczara W., Górski D., Iwański G. et al., *Kompensacja mocy biernej generatorów indukcyjnych w małych elektrowniach wodnych. (Reactive Power compensation of induction generators for small hydropower stations)*. Napędy i Sterowanie 9(149): 144-149 (2011), (in Polish).
- [3] Mściwójewski E., *Problem kompensacji mocy biernej pobieranej przez generatory asynchroniczne w małych elektrowniach wodnych. (Issue of reactive power compensation for induction generators at small hydropower plants)*. Instytut Energetyki O/Gdańsk (1996), (in Polish).
- [4] Rozłucki W., *Kompensacja mocy biernej w małych elektrowniach wodnych (MEW). (Compensation of reactive Power for small hydropower stations)*. ELMA ENERGIA, (in Polish).
- [5] http://www.sabur.com.pl/pl/nasza_oferta/sterowniki_swobodnie_programowalne_dla_automatyki/pcd3_modu_%C5%82owe/id_1069.html, Saia PCD3-M6340, accessed June 2011.
- [6] http://www.pnec.org.pl/projekty_gmin/Olsztynek%20%20małe%20elektrownie%20wodne.pdf Małe elektrownie wodne – Olsztynek (woj. warmińsko-mazurskie), accessed June 2011.
- [7] http://www.sbc-support.ch/manuals/26-839_en_manual_pcd3m6340_can-on-classic.pdf CAN-Functions on PCD2.M5_ & PCD3 CPU Serie Classic Manual, accessed June 2011.