

Marek ROCH
Peter BRACINÍK
Juraj ALTUS
Alena OTČENÁŠOVÁ

CONTROL OF SINGLE-PHASE POWER ACTIVE FILTERS

ABSTRACT *This paper deals with three methods of determination of reference current for control of single-phase active filters. All these methods are based on the idea that an ordinary single-phase (system) quantity can be complemented by a fictitious second phase so that both of them will create an orthogonal and orthonormal system.*

Keywords: *single-phase parallel active filter, Fourier analysis, reference current determination, moving average method*

1. INTRODUCTION

Power systems use power converters. Power semiconductor converters work in switching mode and therefore they are sources of higher harmonic components of the current and voltage in distribution systems. These ones cause electromagnetic interference of the low voltage systems.

Ing. Marek ROCH, PhD., Ing. Peter BRACINÍK, PhD.

e-mail: Marek.Roch@kves.uniza.sk; Peter.Bracinik@kves.uniza.sk

prof. Ing. Juraj ALTUS, PhD., doc. Ing. Alena OTČENÁŠOVÁ, PhD.

e-mail: Juraj.Altus@kves.uniza.sk; Alena.Otcenasova@kves.uniza.sk

Department of Power Electrical Systems, Faculty of Electrical Engineering
University of Zilina

Passive filters are not very sufficient in this case because the switching frequency of a converter usually varies.

Active filters consist of power electronics and a source of energy (active part of the filter) and hence they are able to keep up with any changes in

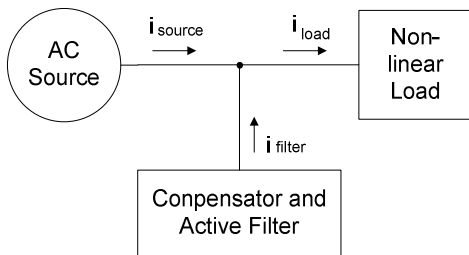

Fig. 1. Basic scheme of parallel compensation and filtering

switching frequency of a converter. They cannot limit sources of higher harmonics. They are only able to filter higher harmonic components of voltage and current near the place of their generation and can ensure that higher harmonic components of current and voltage will not be transmitted through the distribution systems. Only harmonic components caused by switching frequency of active filter occur. The switching frequency is kept constant and

therefore this frequency can be filtered by passive filter.

Active filters represent big benefit by means of energy saving. Active filters, which have been used recently, compensate only power factor and lower harmonic components of load current because of the power electronic losses limitation.

2. SINGLE-PHASE PARALLEL ACTIVE FILTER

The current of the loads, which needs (considering its non-linear nature) to be supplied by reactive and distortion powers will be composed of harmonic components with unity power factor against the network supply voltage and non-harmonic component, constituted by reactive and distortion compensating currents. To eliminate this phenomenon, it is necessary to compensate the power factor and filter the higher harmonics, better just in the point of their origin, (Fig. 1, 2). Compensators and active filters can do this, even in case of rapidly changing loads.

The main task of such a compensator or active filter (Fig. 3), is generation of complementary compensating current i_{filter} such, that after its addition with non-harmonic and phase shifted load current i_{load} , the only active power and harmonic current i_{source} will be taken off the supplying network:

$$i_{load} = i_{filter} + i_{source} \quad (1)$$

The calculation of this compensating current is the most important activity of the active filter's control circuit. The calculations can be carried out in different ways.

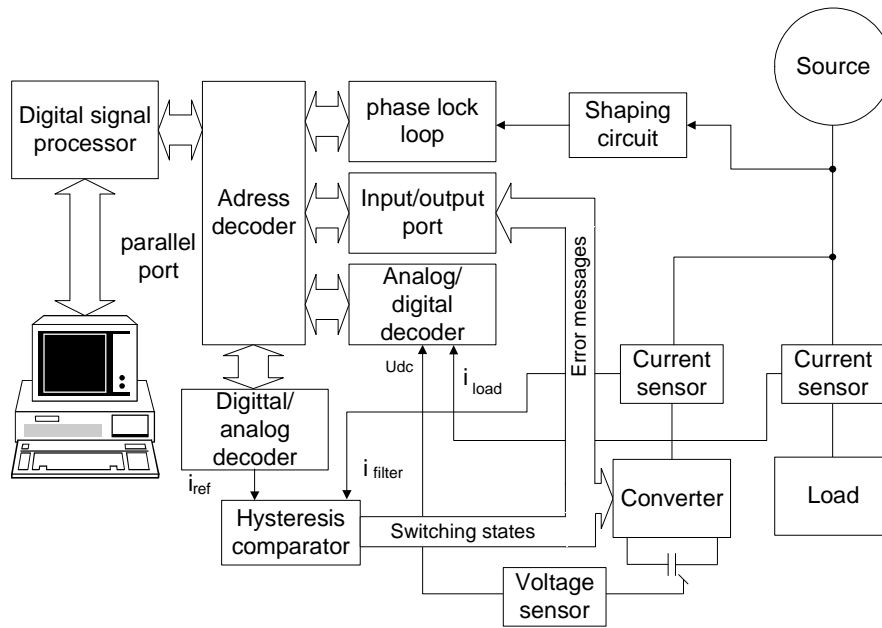

Fig. 2. Block scheme of a parallel active filter

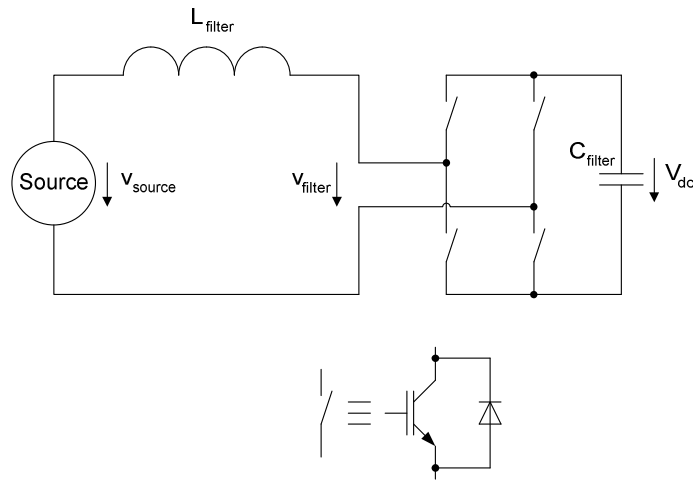

Fig. 3. Basic connection of a single-phase active filter

3. ORTHOGONAL TRANSFORM FOR SINGLE-PHASE SYSTEMS

Completing the harmonic function by its orthogonal component the complex exponential function can be obtained as [1]:

$$\cos(\omega t) \rightarrow \exp(j \cdot \omega t) = \cos(\omega t) + j \cdot \sin(\omega t) \tag{2}$$

This approach can be also used for non-harmonic functions:

$$\sum \cos(\omega t + \varphi) \rightarrow \sum \exp(j \cdot \omega t + \varphi), \text{ etc.} \quad (3)$$

Based on four-side symmetry of the trajectory in the complex plane the orthogonal co-ordinates of the quantities can be generally defined [6]:

$$X(j \cdot \omega t) = K[x(t) + x(t) \cdot \exp(j\pi/2)] \quad (4)$$

thus (for $K = 1$)

$$u_\alpha = u(t), \text{ respectively } u_\beta = u(t - T/4), \quad (5)$$

similarly

$$i_\alpha = i(t), \text{ respectively } i_\beta = i(t - T/4) \quad (6)$$

and similarly for any quantities. Note that the added second phase is just fictitious, an imaginary one.

4. REFERENCE CURRENT DETERMINATION USING INSTANTANEOUS ACTIVE AND REACTIVE POWER (P-Q THEORY)

Using Eq. (5), (6) the instantaneous active and reactive power of the both phases will be [2], [5]:

$$\begin{aligned} p &= u_\alpha \cdot i_\alpha + u_\beta \cdot i_\beta & p &= P_{AV} + P_{AC} \\ q &= u_\alpha \cdot i_\beta - u_\beta \cdot i_\alpha & q &= Q_{AV} + Q_{AC} \end{aligned} \quad (7)$$

Both powers will involve the DC average and AC components. Separation of the DC and AC components is requested due to PAV and QAV determination; average active power must not be supplied by active filter and the average reactive power can be generated by a static VAR compensator. For the separation high pass filter is frequently used. For determination of average active power of the real phase a following equation can be used.

$$P_{AV} = \frac{2}{T} \int_0^{\frac{T}{4}} (u_{\alpha} \cdot i_{\alpha} + u_{\beta} \cdot i_{\beta}) \cdot dt \quad (8)$$

In a similar way one can also determine the average reactive power. Supposing the active filter will generate the whole reactive power, it is not necessary to do it. The reference current for this method is:

$$i_{ref}(t) = \frac{1}{D} \cdot (u_{\alpha} \cdot P_{AC} - u_{\beta} \cdot q), \quad (9)$$

whereas the determinant:

$$D = u_{\alpha}^2 + u_{\beta}^2. \quad (9a)$$

Note, that this approach can be also used for investigation of the power factor defined as:

$$\varphi' = \arctan \frac{q}{p}. \quad (10)$$

5. REFERENCE CURRENT DETERMINATION USING FOURIER ANALYSIS FOR THE 1ST HARMONIC

The complex Fourier coefficient for the 1st harmonic can be now defined within one fourth of period:

$$C_1 = \frac{4}{T} \int_0^{\frac{T}{4}} x(t) \cdot e^{-j\omega t} dt. \quad (11)$$

The magnitude and phase shift of the 1st harmonic component of any quantity $x(t)$ is then:

$$C_1 = \sqrt{(C_{1\alpha}^2 + C_{1\beta}^2)}, \quad \varphi_1 = \arctan \frac{C_{1\beta}}{C_{1\alpha}}, \quad (12)$$

where the 1st harmonic components are:

$$C_{1\alpha} = \frac{4}{T} \int_0^{T/4} (x_\alpha(t) \cdot \cos(\omega t) + x_\beta(t) \cdot \sin(\omega t)) \cdot dt, \quad (13)$$

$$C_{1\beta} = \frac{4}{T} \int_0^{T/4} (x_\beta(t) \cdot \cos(\omega t) - x_\alpha(t) \cdot \sin(\omega t)) \cdot dt. \quad (14)$$

The reference current can be computed as:

$$i_{ref}(t) = i_{load}(t) - I_1 \cdot \cos \varphi_1 \cdot \cos \omega t. \quad (15)$$

6. REFERENCE CURRENT DETERMINATION USING INSTANTANEOUS ACTIVE POWER – MOVING AVERAGE METHOD

Eq. 8 can be used for determination of the average value of the load active power.

For numerical computing of the integral the following relation should be used:

$$P_{AV} = \frac{1}{N} \sum_{k=1}^{N-1} [p(k \cdot \Delta T) + (p(0) + p(N)/2)], \quad (16)$$

where $p(k \cdot \Delta T) = u_a(k \cdot \Delta T) \cdot i_a(k \cdot \Delta T) + u_b(k \cdot \Delta T) \cdot i_b(k \cdot \Delta T)$ and it is computed in each integration step, which means that a new value is computed by the moving average method [7]. The 1st harmonic magnitude of load current can be gained by dividing by the amplitude of the source voltage:

$$I_1 = \frac{2 \cdot P_{AV}}{U_m}. \quad (17)$$

So the reference current of active filter:

$$i_{ref}(t) = i_{load}(t) - I_1 \cos(\omega t). \quad (18)$$

7. SIMULATION EXPERIMENTS

Simulation results of all described methods are presented in the following figures: Figure 4 – load current, Figure 5 – reference active filter currents computed by all three methods, Figure 6 – reference current by the 1st method (p-q method), Figure 7 – source current computed by the 1st method (p-q method).

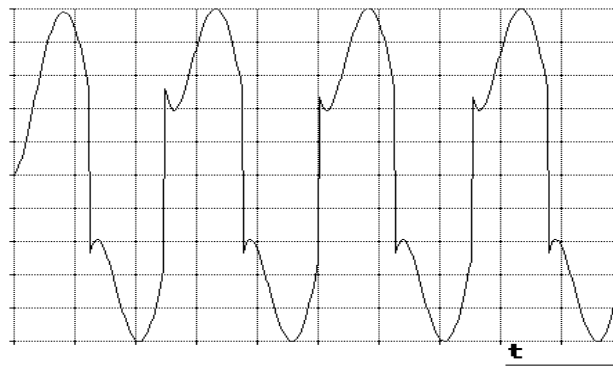

Fig. 4 The waveform of the load current

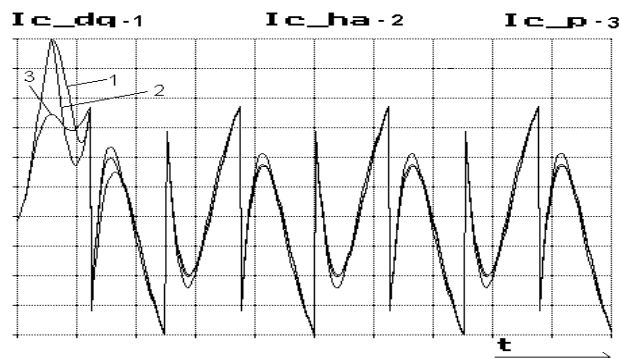

Fig. 5 Reference active filter currents computed by all three methods: 1 – p-q method; 2 – Fourier analysis method; 3 – moving average method

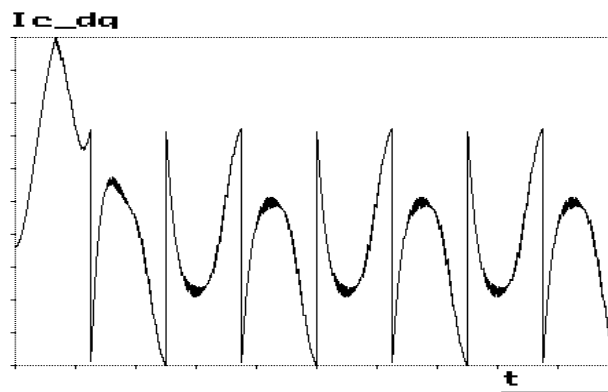

Fig. 6 Active filter reference current obtained using the p-q method

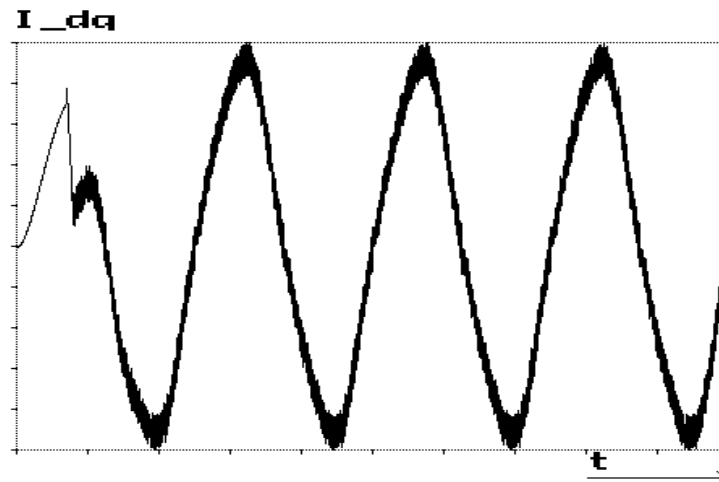

Fig. 7. Source current computed by the p-q method

8. CONCLUSIONS

Three different computing methods for determination of the reference current of the active filter have been introduced. The results of simulation experiments of the load current, source current and reference currents computed by the three above mentioned methods are given in the paper. The results show that there is no big difference between the reference currents in steady state. It is clear, that the moving average active power method is most suitable from the point of view of calculation time. The speed of reference current computation is very important for transient behaviour of the active filter in dynamic changes of the load and other external disturbances of the active power filter circuitry. This influence can be seen from the shape of reference current at the beginning of active filter operation (Fig. 5 and Fig. 6). The filter needs one quarter of period to buffer values of load current to be able to provide correct calculation of the reference current needed.

Acknowledgements

The authors wish to thank for the support to the R&D operational program Centre of excellence of power electronics systems and materials for their components, No. OPVaV-2008/2.1/01-SORO, ITMS 26220120003 funded by European Community.

LITERATURE

1. Kneppo L.: The AC currents, Edition Centre of STU University, Bratislava (S.R.), 1975.
2. Akagi H., Kanazawa Y., Nabae A.: Instantaneous Reactive Power Compensators Comprising Switching Devices without Energy Storage Components, IEEE Transactions on IA., Vol. 20, 1984, No. 3, pp. 625-630.
3. Roch M.: Distributed Control of Power Semiconductors Systems, Ph.D. Thesis., STU Bratislava, 2006.
4. Dobrucký B., Kim H., Ráček V., Roch M., Pokorný M.: Single-Phase Power Active Filter and Compensator Using Instantaneous Reactive Power Method, Proceedings of IEEE-PCC'02, Osaka, apríl 2002.
5. Vas P.: Electrical Machines and Drives, A Space Vector Theory Approach, Clarendon Press, Oxford, 1992.
6. Dobrucký B.: The Input- and Output Equations of Voltage Sourced Inverter in Orthogonal Coordinates, Proceedings of 9th International Conference of University of Transport and Communications in Zilina, Sept. 1993, pp. 133-140.
7. Yutaka O., Masatake K., Koichi N.: Real-Time Phasor Transformation of the State Parameters in Electric Power System by using DSP, Proceedings of ICSPAT'98 Conference., Toronto (CAN), Sept. 1998, pp. 916-920.

Manuscript submitted 18.04.2012

STEROWANIE JEDNOFAZOWYMI
ENERGETYCZNYMI FILTRAMI AKTYWNYMI

Marek ROCH, Peter BRACINÍK
Juraj ALTUS, Alena OTČENÁŠOVÁ

STRESZCZENIE *Artykuł traktuje o trzech metodach ustalania prądu odniesienia do sterowania jednofazowym filtrem aktywnym. Wszystkie te metody bazują na założeniu, że zwykły układ jednofazowy może być uzupełniony przez fikcyjną drugą fazę tak, że obie tworzą układ ortogonalny i ortonormalny.*

Słowa kluczowe: *jednofazowy filtr aktywny, analiza Fouriera, wyznaczenie prądu odniesienia, metoda średniej ruchomej*

