

Ján Kaňuch, Peter Višny
Technical University of Košice, Koszyce

DC DRIVE FOR UNIVERSAL MOTOR

Abstract: Universal motors are usually operated in AC mode and are controlled by means of triacs. This conventional solution is characterized by a cheap control hardware. On the other hand, it has some drawbacks. In particular the high peak to peak current gives poor motor efficiency and the consequential high brush temperature leads to limited motor lifetime.

Significant improvements are obtained when using a more exacting converter. This paper presents the results obtained by using a diode rectifier and PWM controlled IGBT chopper. The RMS and peak-to-peak current of the motor are reduced, as well as electric losses and brush temperature. In addition, this operation mode enables increasing the motor output power or the motor lifetime. In order to reduce switching losses and electromagnetic interference of the converter, the assumed switching frequency is not higher than 1000 Hz.

1. Introduction

In principle a universal motor (Fig. 1) is similar to a serial DC motor. However, the universal motor is designed for AC operation. It is capable to operate at either AC or DC current. Therefore its construction is a little different. The magnetic circuits of stator and rotor consist from iron sheets reducing the electric losses caused by AC current or AC current component produced by a PWM chopper. Otherwise, the windings of the universal motor correspond to the windings of a common DC motor. The coils of the rotor winding are connected the commutator segments, which allows to maintain the direction of the rotor magnetic field nearly perpendicular to the stator magnetic field. Small universal motors usually have no compensation and commutation winding, they have two salient poles with excitation winding. The stator winding of the universal motor has low resistance and inductance allowing to operate the motor in serial connection of the rotor and stator windings.

permanent magnet, the universal motor produces the electric torque proportional to the square of the supply current. So the electric torque has the same torque direction at any current polarity as well as at AC current.

Universal motors have some excellent properties. They are characterized by high power related to their size and weight, compared to induction motors. They have very good inherent control properties. They can be operated at extremely high speed (15 000 to 20 000 rpm) and have very good starting torque, which makes them suitable for applications such as power drills, washing machines, dust extractors. On the other hand, universal motors have also their drawbacks. Universal motors are very loud. Compared to induction motors, they have lower life time due to wearing of the commutator. In addition, the commutator produces sparks which make these motors unsafe for use in flammable environment.



Fig. 1. Universal motor

Unlike a DC motor with separate excitation or

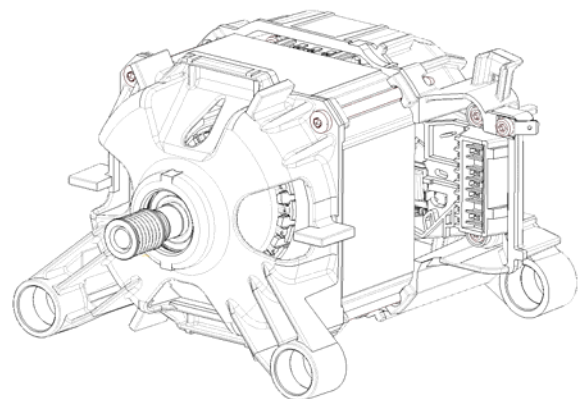

Fig. 2. Universal motor produced by BSH

Fig. 2 shows the construction of the universal

motor produced by BSH Drives and Pumps, Factory Michalovce, Slovakia. The motor is intended first of all for use in washing machines of BSH. It is generally supplied by triac converter.

2. Speed control of a universal motor

For speed control of a universal motor it is possible to use either converters with phase-angle control (using triacs or thyristors) or PWM converters (using transistors). The output voltage can be adjusted manually or automatically using speed control (i.e. speed is adjusted manually). Since universal motors are intended first of all in home applications, the converters must be designed for operation at single phase AC line. The following types of converters are most frequent for universal motors:

- single triac
- half-controlled thyristor bridge rectifier
- IGBT chopper with diode rectifier

2.1. AC drive with triac

Fig. 3 shows an AC drive for common universal motor used in a large range of applications. One triac is sufficient for control. This is the most simple and cheap solution. The main disadvantage of such drive is a very high current ripple especially at low speed. As well the AC input current waveform is very unfriendly. Therefore such drive is advisable especially for applications operating at higher speeds.

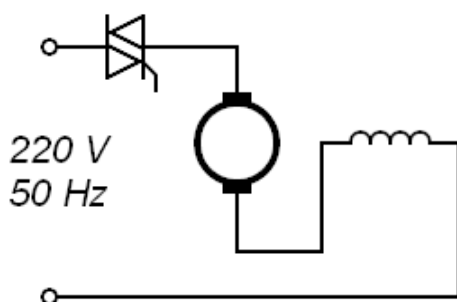

Fig. 3. Universal motor supplied by triac

2.2. DC drive with rectifier

Fig. 4 shows a universal motor with a half-controlled thyristor rectifier. This solution is more perfect and more expensive compared with triac drive. Due to DC output voltage the losses in the magnetic circuit as well as the torque ripple are reduced.

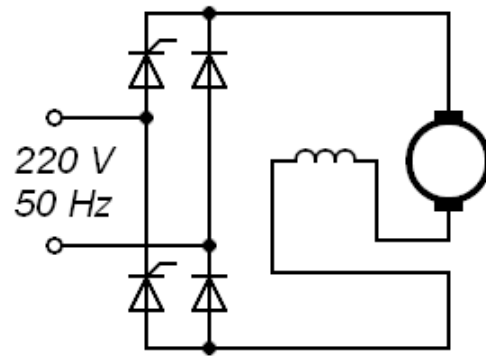

Fig. 4. Universal motor supplied by thyristor rectifier

2.3. DC drive using an IGBT and a rectifier

Fig. 5 shows a universal motor with an IGBT chopper. The Pulse Width Modulation (PWM) technique is used for voltage adjustment. Compared to converters with phase-angle control the PWM converter is more complex and more expensive. The advantage of using this type of converter is reducing the torque ripple and acoustic noise of the motor. However, due to the transistor operation the input AC current is periodically interrupted with the switching frequency. So the converter returns to the power line high frequency current component and that is why it is undesirable to use very high switching frequency. The use of a filtering capacitor is avoided because small weight and dimensions of the converter usually are preferred.

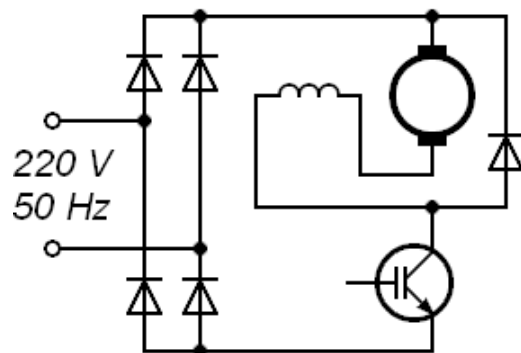

Fig. 5. Universal motor supplied by IGBT chopper

3. Practical experiments using IGBT chopper for supplying a universal motor

For practical experiments was used the common universal motor produced by BSH company (Fig. 2). It is designed for supplying by a triac from a single phase power line (220 V) at maximum RMS current 5 A. However, the

measurements were done using an IGBT chopper (Fig. 5). The type of the IGBT chosen for the experiments is BUP314 and the type of the switching diode was BY399. The measurements were done at direct PWM control without any feedback. The popular circuit UC3843 was used as PWM pulse generator. A potentiometer was used for changing the duty cycle of the PWM pulses at constant frequency. The control circuits with the potentiometer along with power components were placed on a universal contact field (Fig. 6). A capacitor of 330 nF at the rectifier output was put immediately near the transistor and the diode only for eliminating parasitic overvoltages. Its influence on the power behavior of the system is negligible. The only components placed outside of this picture were the diode rectifier, the power supply for the control circuits and the current sensor for the oscilloscope.

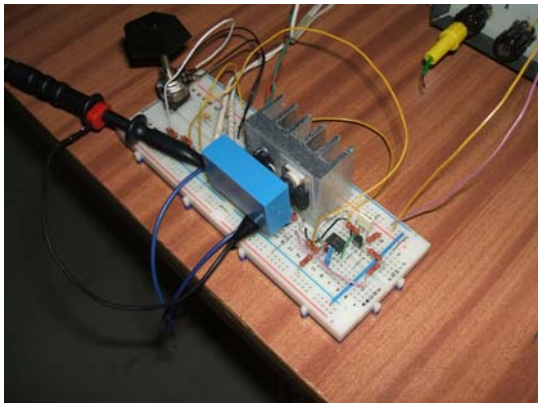

Fig. 6. View of the arrangement for experiments

The goal of the measurements was to document the electric behaviour of the system in steady-state at various values of the motor current, motor speed and switching frequency. The motor was mechanically loaded by a dynamometer – equipment that forces a defined speed of the measured motor at varying torque depending on the motor current.

3.1 Measurement of the motor current and voltage waveforms at various speed

Assuming the common mathematical model of a universal motor, the theoretical substitutional electric scheme of the universal motor consists of a constant inductance and variable resistance in serial connection. The substitutional resis-

tance consists of the real resistance of stator and rotor winding and of the virtual resistance proportional to the speed. The substitutional electric scheme does not contain DC voltage source usual for DC motors with separate excitation. As the result, the current of the universal motor supplied by a chopper with a rectifier is never interrupted.

Practical electric behaviour of the universal motor is a little different from the theoretical behaviour due to commutation of the rotor current.

The following four figures show the motor voltage and current at various speeds. The chosen switching frequency is 750 Hz. The voltage scale (red) is 200 V/div, the current scale (blue) is 2 A/div. The time base has 1 ms/div.

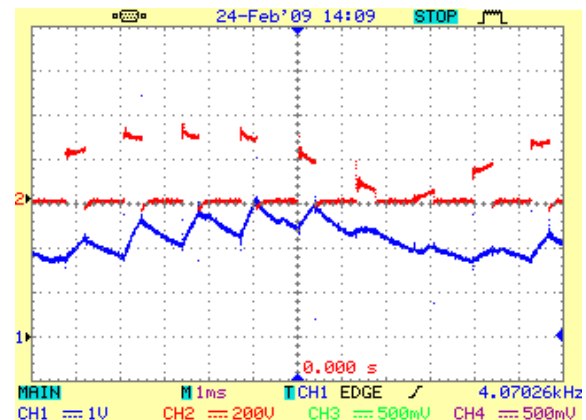

Fig. 7. Motor current and voltage at torque 1 Nm and speed 1000 rpm

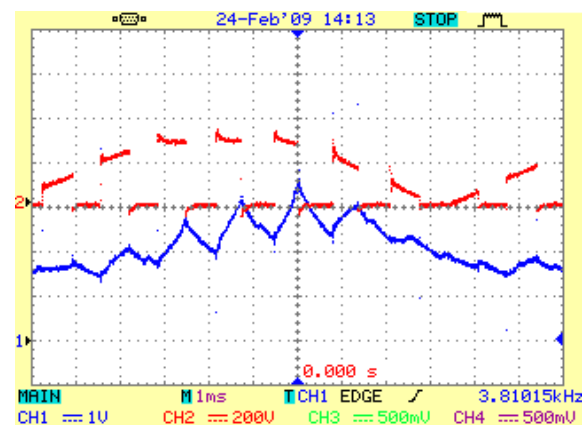

Fig. 8. Motor current and voltage at torque 1 Nm and speed 2000 rpm

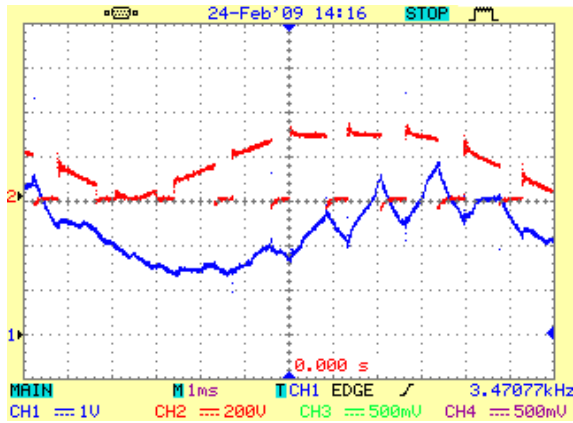

Fig. 9. Motor current and voltage at torque 1 Nm and speed 3000 rpm

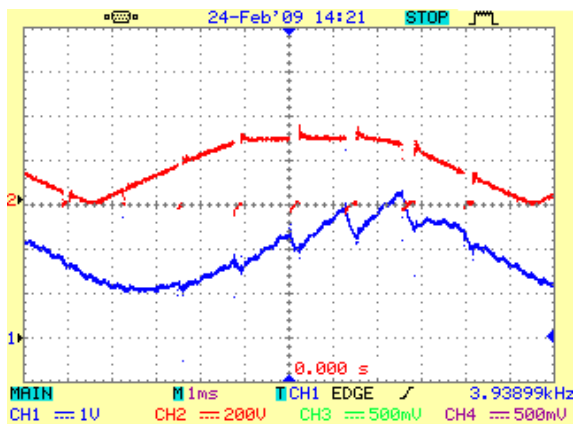

Fig. 10. Motor current and voltage at torque 0,8 Nm and speed 5000 rpm

At the last measurement (Fig. 10) it was impossible to reach the torque of 1 Nm, therefore the torque was 0.8 Nm.

3.2. Measurement of the efficiency and power factor at various torque and speed

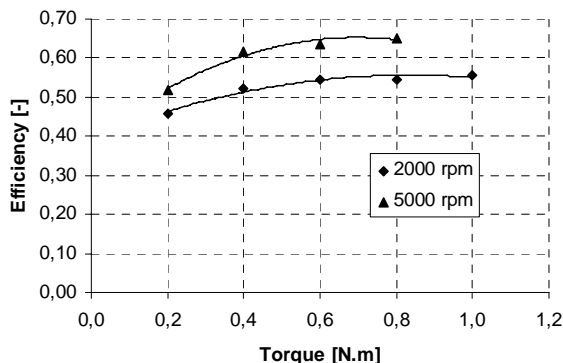

Fig. 11. Motor efficiency dependent on the torque at speed of 2000 and 5000 rpm

Fig. 11 shows the efficiency depending on the torque at two values of speed. Fig. 12 shows the power factor depending on the torque at two values of speed.

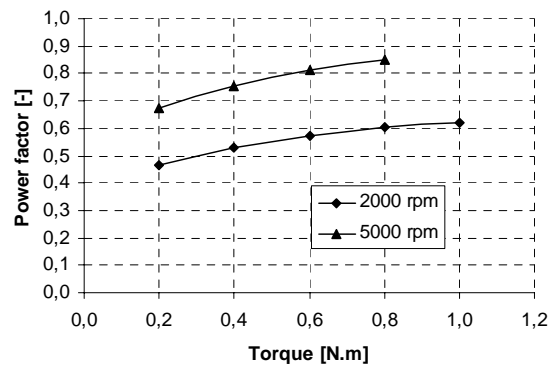

Fig. 12. Motor power factor dependent on the torque at speed of 2000 and 5000 rpm

3.3. Measurement of the efficiency and power factor at various PWM frequency

The previous sections present the results obtained at the PWM frequency of 750 Hz. In this section are compared results obtained at the PWM frequencies of 500 Hz, 750 Hz and 1000 Hz. Fig. 13 shows the efficiency depending on the torque at the PWM frequencies of 500 Hz, 750 Hz and 1000 Hz and speed 2000 rpm.

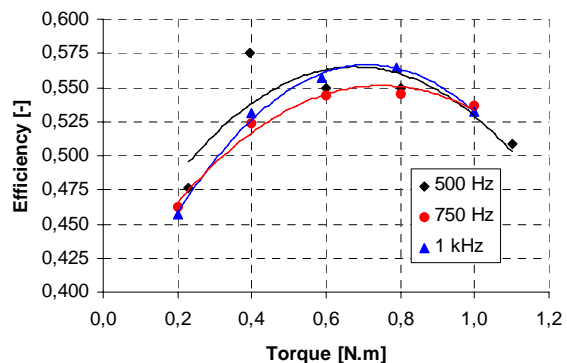

Fig. 13. Motor efficiency dependent on the torque at speed of 2000 rpm

Fig. 14 shows the power factor depending on the torque at the PWM frequencies of 500 Hz, 750 Hz and 1000 Hz and speed 2000 rpm.

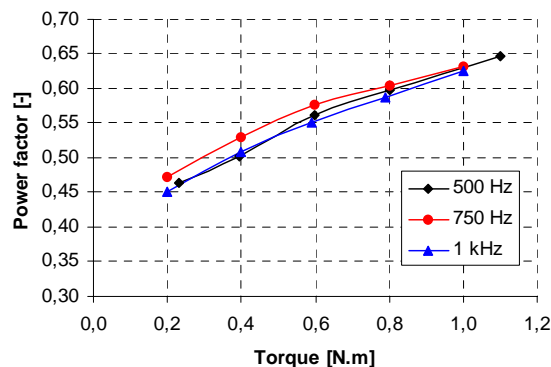

Fig. 14. Motor power factor dependent on the torque at speed of 2000 rpm

3.2. Measurement of the motor current and voltage waveforms at various PWM frequency

The measurements was made at constant torque of 1 Nm and speed of 2000 rpm. The following figures show the voltage and current waveforms at the PWM frequency of 500 Hz, 750 Hz and 1000 Hz. It is evident that the current ripple at 1000 Hz is by 50% smaller than the current ripple at 500 Hz.

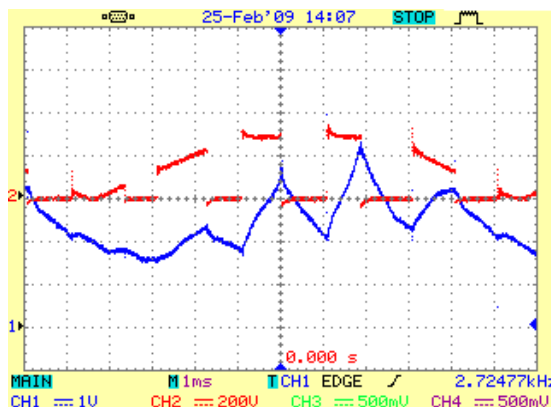

Fig. 15. Motor voltage and current at speed of 2000 rpm and PWM frequency of 500 Hz

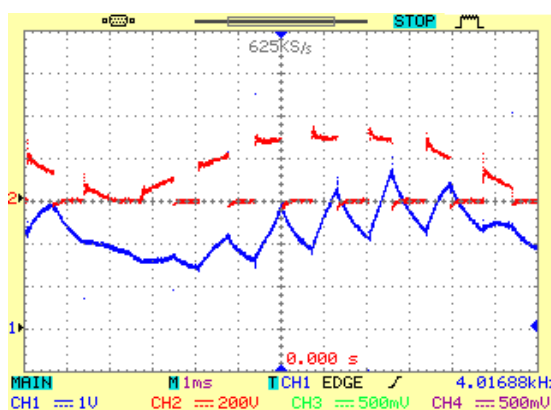

Fig. 16. Motor voltage and current at speed of 2000 rpm and PWM frequency of 750 Hz

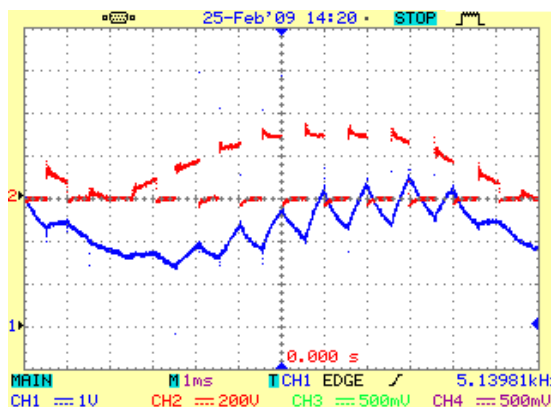

Fig. 17. Motor voltage and current at speed of 2000 rpm and PWM frequency of 1000 Hz

5. Conclusions

The motor current is never interrupted.
The current ripple decreases with PWM frequency.
The efficiency and the power factor increase with the motor speed.
The PWM frequency has small influence on the efficiency and the power factor.

5. Acknowledgement

This work was supported by Slovak Research and Development Agency under project APVV-0510-06 and APVV-0095-07.

6. Bibliography

- [1] Ferkova Ž., Fedor J., Dupej J.: *Influence of magnetic field distribution on commutation of one phase commutator motor*, *Elektrotechnik in praxis*, No. 1-2, pp. 44-45, 2004, Ostrava, Czech Republic, (in Slovak)
- [2] Záskalická M.: *Applications of the Fourier series by the Solution some Problems of Power Electronic*; SEKEL 2004, International Conference of the Teachers of Electrical Engineering, 22-24 september 2004, Písek u Jablunkova, pp. 40-43, Technical University Ostrava, 2004, Czech Republik (in Slovak)
- [3] J. Michalík, M. Šimko, M. Šebök, M. Chupáč: *Diagnostics of electric machines*, *Electro'97 Conference*, 23.- 24.6.1997, pp. 101-104, University of Žilina, Slovakia
- [4] Hrabovcová V., Rafajdus P., Franko M.: *Measuring and modeling of the electrical machines*; University of Žilina press, 2004, Slovakia. (in Slovak)
- [5] Fitzgerald A.E., Kingsley Ch., Umans S.D.: *Electric machinery*; McGraw-Hill Higher Education, New York 2003
- [6] Sen P.C.: *Principles of Electric Machines and Power Electronics*; John Wiley&Sons, USA, Canada 1997
- [7] Záskalický P., Záskalická M.: *Torque ripple calculation of an universal motor supplied by a triac converter*; *Acta Technica CSAV No: 52 (2007)*, 33-43, Prague, Czech Republic
- [8] Židek, K. Maxim, V., Lupták, M.: *Simple Semiconductor Switch in Zero of AC Voltage with Minimum Electromagnetic Influence (EMC) on Power Supply Network*, *MTM – Machines, Technologies, Materials*, No. 1/2008, Publ. by Scientific-Technical Union of Mechanical Engineering, Bulgaria, pp. 6-9, ISSN 1313-0226

Authors

Ján Kaňuch, Ing./PhD.,
e-mail: jan.kanuch@tuke.sk
Peter Višny, Ing./PhD.,
e-mail: peter.visnyi@tuke.sk
Department of Electrical, Mechatronic and Industrial Engineering,
Faculty of Electrical Engineering and Informatics
Technical University of Košice,
Letná 9, 042 00 Košice, Slovak Republic