

Karel Chmelík, Stanislav Mišák
Technical University of Ostrava, Ostrava

SMALL POWER GENERATOR FOR WIND POWER PLANTS

GENERATORY MAŁEJ MOCY DO ELEKTROWNI WIATROWYCH

Abstract: the most important Renewable Energy Sources in the Czech Republic are: water plants, biomass, biogas, wind power plant, liquid biofuel and photovoltaic systems. Most progressive RES production growth we can observe in past ten years at biomass, biogas and water plants. But most dynamically grows Wind Power Plants electric energy production. Systems of Wind Power Plant with generators with nominal power more than 2 MW grows mostly.

Systems of Wind Power Plant with nominal power more than 15 kW are developed at present too. These systems are used for production of electric energy in autonomous electric systems for single-family house, remote areas and so on.

1. Introduction

The power of wind is kind of renewable sources on the world. For utilization these sources are used wind power-plants with electrical generators. The generator transforms mechanical power of wind to electrical power.

The induction generator is used mostly for transformation of mechanical energy. The induction generator has these characteristics important for use in wind-power plants:

- easy control and operating of generator,
- cheaper technology of production,
- less weight,
- high reliability,
- possibility of use standard induction motor.

Disadvantage of using induction generator is necessity supply and control of reactive energy. The control system with synchronous generator with permanent magnets is extended in the present time. The reason of expansion of usage is diminishing price of generator and higher efficiency of system in comparison to system with induction generator.

The possibility of use small induction generator manufactured as an induction motor and synchronous generator with permanent magnets working in autonomous power network and working in parallel run with distribution network will be described in this paper.

2. Induction motor as a generator

Small wind power plants can work with induction generator manufactured as a motor, the re-computation some nominal parameters of machine for generator mode is necessary.

The modification energy flow of machine occurs in the generator mode. The characteristics parameters of induction motor are classified by these rules [2]:

The output power is mechanical power on the shaft of machine and it is solved by formula (1).

$$P_{SH} = \omega \cdot M = \frac{\pi \cdot n \cdot M}{30} \quad (1)$$

where M (N·m) is moment on the shaft and n (rpm) are revolution per minute of the shaft. The input power of motor is electrical power in terminals of machine according to equation (2)

$$P_{EL} = 3 \cdot U \cdot I \cdot \cos \varphi \quad (2)$$

Where U (V) is rated voltage, I (A) is rated current and $\cos \varphi$ (-) is rated power factor. Losses are defined as a difference between input and output power, see equation (3).

$$P_{LOS} = P_{INP} - P_{OUT} \quad (3)$$

The input power is mechanical power on shaft according to formula (1) and output power is electrical power according to formula (2) for generator mode of induction machine. The lose flow is changed and losses are refunded by mechanical energy. Some values of electrical and magnetic quantities are changed for this replacement in the machine. This fact is introduced by equivalent circuit in the Fig. 1.

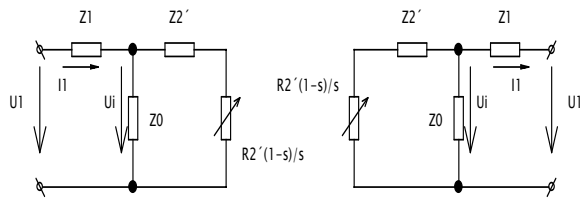

Fig. 1. The equivalent circuit of induction machine

Equivalent circuits of a) induction motor and b) induction generator are shown in the Fig. 1. The inner generated voltage is given by formula (4) for motor mode of induction machine.

$$U_i = U_1 - Z_1 \cdot I_1 \quad (4)$$

Further, the inner generated voltage is given by formula (5) for generator mode of induction machine.

$$U_i = U_1 + Z_1 \cdot I_1 \quad (5)$$

Where U_i (V) is inner generated voltage, U_1 (V) is terminal voltage and $Z_1 \cdot I_1$ is voltage drop of stator. For case, when the terminal voltage is constant in motor and generator mode of induction machine, the inner generated voltage is higher about double stator voltage drop of. The size of inner generated voltage is influenced by magnetic flow in machine according to formula (6),

$$\phi = \frac{U_i}{4,44 \cdot N_1 \cdot f_1 \cdot k_{v1}} \quad (6)$$

The mounting magnetic flow grows up magnetic inductance, magnetic losses and magnetic current. The magnetic current is dependent on power factor of the machine and size of reactive energy.

In case, when the induction machine works with decreased terminal voltage about double value of stator voltage drop, the machine retains its constant power factor. The decreased terminal voltage and losses replacement limitative of rated power of machine. The rated power of the induction machine for generator mode is only 50 to 70 percent of rated power for the motor mode.

Therefore, the using machine with double size of rated power and machine running with decreases terminal voltage is necessary for using induction motor as a generator in practice.

3. Induction generator working in autonomous network

Most of small wind-power plants are installed in remote countries for supply in autonomous networks. The supply of reactive energy to the terminal of induction generator is needful for creation of electromagnetic field in the induction generator. The reactive energy is obtained from the capacitors. It is assumed that size of the generator inductance is same as a capacitor capacitance according to the formula (7).

$$X_c = X_L \quad (7)$$

The formula (7) respects simplification, when the no-load current is reflected as magnetization current. The value of required capacitive reactance will be obtained by formula:

$$X_c = \frac{U_{1f}}{I_0} \quad (8)$$

and then value of the capacity:

$$C = \frac{1}{2 \cdot \pi \cdot f \cdot X_c} \quad (9)$$

Every electric source is characterized by inner resistance with value R_i . This resistance determines so called "hardness source". In case, when the induction machine is used as source of electric energy, the inner resistance is not only one of important parameter of electric source. The leakage reactance affects running state of induction machine too. The leakage reactance is dependent on load, voltage and frequency. Therefore, the constant terminal voltage is required. The terminal voltage is proportional to capacity of capacitor bank. Thus, the controllable capacitor bank is required too. The increasing capacity of condenser battery is attended by increase of machine losses.

When the electric source is loaded, the terminal voltage is decreased. This voltage drop is given by inner resistance of the source R_i and determines "hardness" of the source. And next, the value of voltage drop influences reactive current (see formula (10)).

$$I_c = 2 \cdot \pi \cdot f \cdot C \cdot U_f \quad (10)$$

When the voltage drop is increased by virtue of increase in load value, the slip is decreased. The slip is zero at synchronous speed and its value is decreased to negative value with speed increasing. At complying with constant rotation

speed of the shaft, synchronous speed n_s will be changed according to formula (11):

$$n = n_s \cdot (1 - s) = konst. \quad (11)$$

The frequency of electric source is given by formula (12):

$$f = \frac{n \cdot p}{60 \cdot (1 - s)} \quad (12)$$

Voltage and frequency drop will have considerable field suppression effect; therefore induction generator will be comparable to soft source with derivational characteristics. Overloading will be attended by decreasing of reactive energy supplied by capacitor and machine will be complete field suppressed. Voltage drop within knee of derivational loading characteristics is bonded to unload drive system. Since certain value of voltage exists, condenser batteries are not able to excite machine and voltage on terminals drops to zero. Power factor of load has influence to “hardness” of source too. In the case, that induction generator is loaded by inductive load, the loading characteristic is “softer”, and for possibility of next load is required higher value capacity of capacitor bank. However, when the capacity in the circuit is increased, running efficiency of generator is decreased.

Generator starting must proceed with disconnected loading. Induced remanent voltage develops current flowing through capacitors, which will excite the generator. In case of connected load, the current by windings of machine will be divided to load current and current flowing through capacitors, according to impedances ratios of load and capacitor.

Last mentioned facts specify conditions for optimal load of generator at autonomous network running [1]:

a) the moment of load connection is determined by value of terminal voltage of induction generator,

b) the value of load impedance is selected according to load characteristic,

c) the maximal efficiency of induction generator is at area “knee” of load characteristic; in this area is generated loaded optimally,

d) induction generator may work all types of the load. However, all of no-resistance loads must be fully compensated. Realization of control optimal run of the generator can be realized by voltage guards or multifunction programma-

ble automat with some analog inputs for example.

4. Induction generator working in parallel run with distributive network

Problems of small induction generators running in parallel cooperation with distributive network are in eliminate of switching transient phenomena. The reactive energy is supply by the distributive network. The generator is connected to the network when his rpm (revolution per minute) are in over-synchronous area. The connection of induction generator to distributive network is followed by over-voltages and over-currents. Typical transient phenomena of switching induction generator are drawn in the Fig. 2.

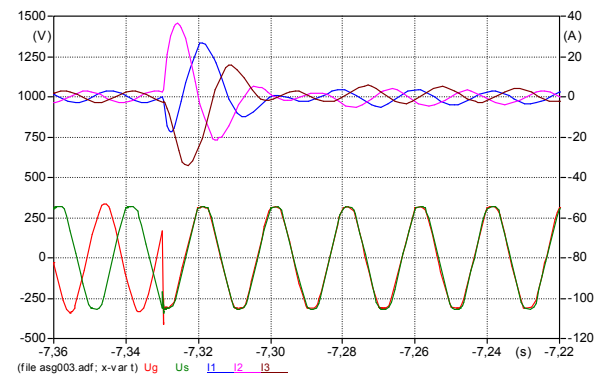

Fig. 2. Transient phenomena of switching induction generator to the distributive network

The over-current is around 10 multiple of rated current in this example. Relevant oscillation of current with switching frequency may cause voltage fluctuation in power network.

There are some methods of eliminate of these transient phenomena. Using frequency converter or softstart is possible to use for example, but these methods are too expensive for small generators. The connection of induction generator with small power to the distributive network is possible to realize in few steps. The first step is switch generator to power grid over resistors by contactor. After a few seconds pause is switch main contactor and disconnect contactor of resistors. This method eliminates the transient phenomena of switching [3]. Over-current raises only fragment of rated current and its value is dependent on value of resistor R. The relation between maximum value of current and size of resistor is introduced in Fig. 3. This relation was obtained for induction gen-

erator (1,1 kW, 6poles, 0,4kV). The I_M is amplitude of over-current.

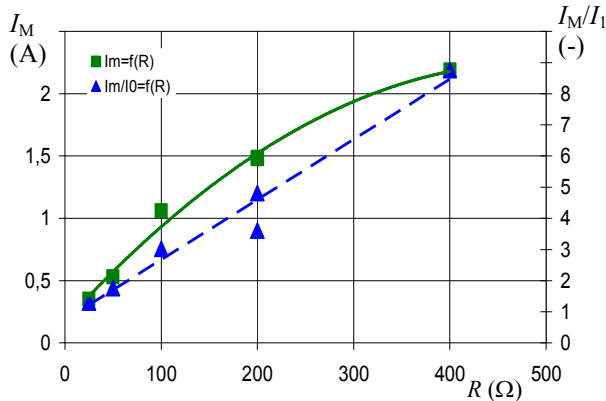

Fig. 3. The relation between over-current and size of resistor R

The optimal switching of small induction generator to power network is shown in Fig. 4.

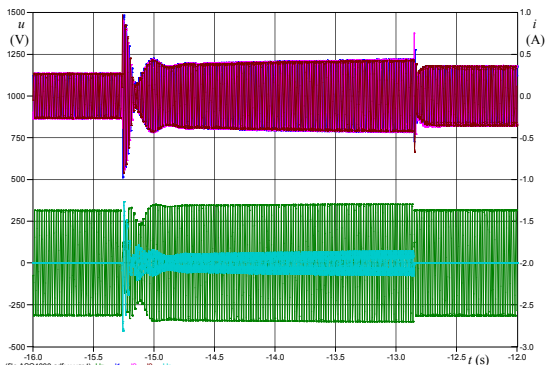

Fig. 4. The optimal switching of small induction generator to the distributive network

Transient phenomena are segmented to two transient phenomena with minimal over-currents and without over-voltages. The view of optimal switching is realized for connection of induction generator 1,1 kW, 6poles by resistor 50 Ohm and 1022 rpm in Fig. 4.

5. Synchronous generator as a source of electric energy at wind power plant

The regulation of voltage at terminal of machine is not possible for case using of synchronous machine with permanent magnets. The value of terminal voltage is defined by characteristic parameters of machine (material parameters of permanent magnet) and by revolutions per minute. This dependence is called as a exciting characteristic (see Fig. 5).

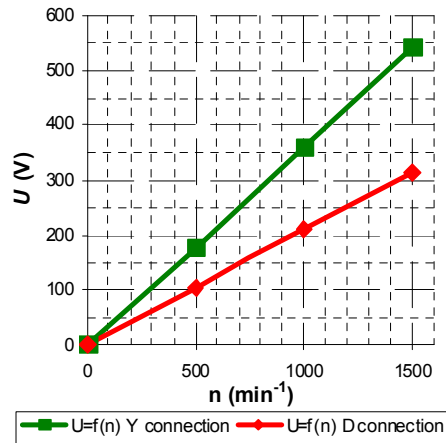

Fig. 5. The exciting characteristic of machine

The direction of curve is called as a voltage constant and this is characteristic parameter of synchronous machine with permanent magnet. The synchronous machine is possible to use as a source of electric energy for wind power plant as well as induction generator. Advantage of using synchronous machine with permanent magnet is unnecessary source of reactive energy. Similarly, as in the case of using induction machine, is possible to use synchronous generator with permanent magnet as a source of electric energy for autonomous network. The load in the form of resistor heating spiral is mostly used for water heating in the family house. This type of load is not dependent on the frequency of output voltage.

The synchronous generator with permanent magnet is possible to operate parallel with distributive network too. The system on the Fig. 6 is applicable to operating of wind power plant to 50 kVA.

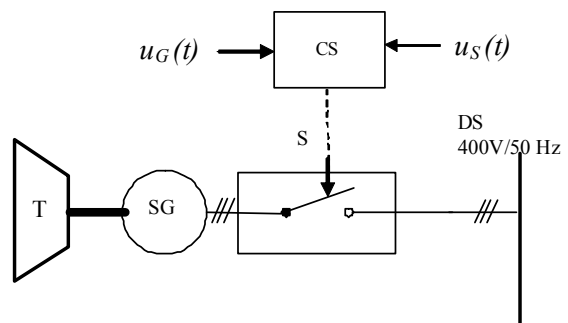

Fig. 6. The block scheme of control system of synchronous generator with permanent magnet.

The synchronous generator must be operated so that terminal voltage has equivalent value as a voltage of distributive network for synchronous revolutions per minute. Synchronizing condi-

tions have to be realized for switching synchronous generator to distributive network.

For reduction of current surges have to be realized these conditions:

- identical phase sequences for generator and distributive network,
- identical frequency of generator and distributive network,
- identical amplitude generator voltage and voltage of distributive network,
- identical phase generator voltage and voltage of distributive network in the moment of switching.

The switching by control system of wind power plant is realized subsequently: instantaneous values of generator voltage $u_G(t)$ and distributive network voltage $u_S(t)$ is traced by synchronizing device "CS". The synchronous generator is connected to distributive network at the moment completion of switching conditions. The example of switching synchronous generator 50 kVA to distributive network is shown in the Fig. 8.

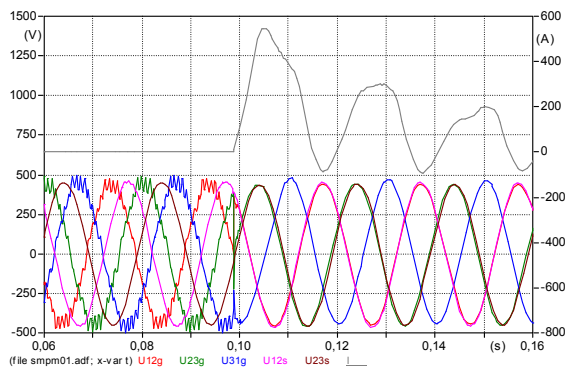

Fig. 8. The course of generator voltages (U_{12g} , U_{23g} , U_{31g} (V)), voltages of distributive network (U_{12s} , U_{23s} (V)) and course of current at the moment of generator connection to distributive network

6. Conclusion

Simple systems of wind power plants with nominal power to 50 kW are introduced within this paper. Induction generator and synchronous generator with permanent magnets were used as a source of electric energy at wind power plant. Results from measuring characteristic parameters of mentioned types of generators for autonomous network and parallel cooperation with distributive network are shown in the paper too. Future research will be directed to compare yield of these systems on measure base.

This paper was created under research project MSM 6198910007.

Bibliography

- [1]. Nevřala J.: *The Induction Machines for Wind-Power Plants*, Diploma Thesis, VŠB-TU Ostrava 2005.
- [2]. Chmelík, K.: *Asynchronní a synchronní elektrické stroje*, VŠB TU Ostrava, 2002, ISBN 80-248-0025.
- [3]. Nevřala, J.; Chmelík, K.; Mišák, S.: *Větrné elektrárny*, Časopis pre elektrotechniku a energetiku EE, Bratislava, 10/2007, page 75-78, ISSN 1335-2547.

Authors

Doc. Ing. Karel Chmelík, Ing. Stanislav Mišák, Ph.D.

Technical University of Ostrava, Faculty of Electrical Engineering and Computer Science, Department of Electric Machines and Apparatus, 17. listopadu 15, 708 33 Ostrava-Poruba, Czech Republic.

e-mail: karel.chmelik@vsb.cz,
stanislav.misak@vsb.cz