

# COMPARISON OF EXPERIMENTAL DATA AND NUMERICAL SIMULATION OF TWO-PHASE FLOW PATTERN IN VERTICAL MINICHANNEL

Jarosław Sowiński\*, Marek Krawczyk, Marek Dziubiński

Technical University of Lodz, Faculty of Process and Environmental Engineering,  
ul. Wólczańska 213, 90-924 Łódź, Poland

The aim of the study was the implementation of a numerical simulation of the air-water two-phase flow in the minichannel and comparing results obtained with the values obtained experimentally. To perform the numerical simulations commercial software ANSYS FLUENT 12 was used. The first step of the study was to reproduce the actual research installation as a three-dimensional model with appropriate and possible simplifications – future computational domain. The next step was discretisation of the computational domain and determination of the types of boundary conditions. ANSYS FLUENT 12 has three built-in basic models with which a two-phase flow can be described. However, in this work Volume-of-Fluid (VOF) model was selected as it meets the established requirements of research. Preliminary calculations were performed for a simplified geometry. The calculations were later verified whether or not the simplifications of geometry were chosen correctly and if they affected the calculation. The next stage was validation of the chosen model. After positive verification, a series of calculations was performed, in which the boundary conditions were the same as the starting conditions in laboratory experiments. A satisfactory description of the experimental data accuracy was attained.

**Keywords:** two phase flow, minichannel, flow pattern, numerical simulation

## 1. INTRODUCTION

Numerical calculations through constant improvement of numerical algorithms and mainly due to greater computing capabilities of computers are becoming more widely used to describe two-phase flow phenomena. It should be noted that a final verification of numerical calculations is an experiment. In the present work one compared the experimentally obtained two-phase of liquid-gas flow parameters in a minichannel with the results obtained by numerical simulation. Numerical calculations were made using commercial software ANSYS FLUENT. It was chosen not only due to the capabilities of the software itself, but mainly as ANSYS FLUENT is generally available and it makes it possible to cooperate with different research teams. A significant advantage of ANSYS FLUENT is also the fact that it has three built-in models for solving multiphase flow problems: Volume-of-fluid (VOF), Mixture and Euler. It allows to choose the best model for solving a given problem and an opportunity to compare these models to obtain the results with the best correlation with experimental results.

In the literature a lot of work on numerical calculations of two-phase flows in micro- and minichannels has been published. As an example one can cite the work of (Gupta et al., 2009; Pohorecki and Kula, 2008; Qian and Lawal, 2006; Santos and Kawaji 2010). An analysis of the literature shows that numerical simulation of a two-phase flow in a minichannel can be achieved by developing one's own

\*Corresponding author, e-mail: sowinski@wipos.p.lodz.pl

prediction model (Pohorecki and Kula, 2008) or using commercial software (Gupta et al., 2009; Qian and Lawal, 2006; Santos and Kawaji, 2010). Pohorecki and Kula (2008), Qian and Lawal (2006) made a numerical simulation of two-phase flow in a minichannel in two dimensions, while Santos and Kawaji (2010) used a three-dimensional geometry to make calculations. Among the commercial software, one of the most commonly used is ANSYS FLUENT (Gupta et al., 2009; Qian and Lawal 2006, Santos and Kawaji 2010).

In the case when ANSYS FLUENT is applied to calculations a different approach to solving the interface can be noted. One of the most popular, easy to use and implement is the Volume-of-fluid (VOF) approach that is used in the work of (Qian and Lawal, 2006; Santos and Kawaji, 2010). It should be noted that numerical calculations using VOF method are strongly dependent on both density and quality of the computational mesh (discretisation of computational domain). This is particularly noticeable if we are interested in presenting films of liquid at the mini or microchannel wall. This problem and possible solutions have been described by (Gupta et al., 2009).

Calculation methodology and the selection of ANSYS FLUENT solver options while using a VOF model were described by several research teams (Gupta et al., 2009; Qian and Lawal, 2006).

## 2. NUMERICAL CALCULATIONS

To simplify numerical simulation of two phase flow in the minichannel the following initial assumptions were made:

1. A two-phase flow under consideration shall be in isothermal conditions – hence physicochemical properties of phases and mixture are constant and independent of temperature.
2. The flow in the minichannel is laminar –a turbulence model is not included. This assumption is consistent with the range of performed experiments.
3. Diffusion between the two phases is negligibly small, thus it is not included either.

### 2.1. VOF model

The numerical simulation of a two-phase flow in a minichannel was performed using the ANSYS FLUENT built-in Volume-of-fluid (VOF) model. This model makes it possible to describe two or more immiscible fluids by solving a system of momentum equations and tracking the volume of each of the fluids in computational domain (FLUENT documentation 2003). One use of a VOF model is prediction of movement of large gas bubbles in the liquid, which is suitable for the considered process. VOF model is also often used in other studies of similar two-phase systems (Qian and Lawal, 2006; Santos and Kawaji, 2010).

Tracking the interface is done by solving the continuity equation for the volume of one (or more) phase. For  $i$ -th phase this equation is as follows:

$$\frac{1}{\rho_i} \left[ \frac{\partial}{\partial t} + \nabla \cdot \left( \varepsilon_i \rho_i \vec{v}_i \right) \right] = S_{\alpha i} + \sum_{j=1}^n \left( \dot{m}_{ji} - \dot{m}_{ij} \right) \quad (1)$$

It should be noted that in Equation (1) there are terms responsible for mass transfer between phases. In this numerical simulation these values were omitted since according to the initial assumptions, mass transfer between the phases does not occur.

Another important equation used in VOF model is the momentum equation, shown below:

$$\frac{\partial}{\partial t} \left( \rho \vec{v} \right) + \nabla \left( \rho \vec{v} \vec{v} \right) = -\nabla p + \nabla \left[ \mu \left( \nabla \vec{v} + \nabla \vec{v}^T \right) \right] + \rho \vec{g} + \vec{F} \quad (2)$$

The equations mentioned above are most significant in the case of solving a VOF numerical model. It should be noticed that these are not only equations of VOF model. A complete list of equations used by ANSYS FLUENT in a VOF model is presented in the software documentation (FLUENT documentation 2003).

### 3. EXPERIMENTAL SET – UP

In order to examine the structure of a two-phase gas liquid flow in vertical mini-channels the experimental set-up was assembled. Its main element was a vertical channel of a rectangular cross-section. In the experiment a channel of the following dimensions: high – 320mm, width - 15 mm and thickness - 0.8 mm was used.

During the experiment the liquid was flowing in a closed circulation, the constant temperature of the examined liquid being maintained by a thermostat with a volume of 15 dm<sup>3</sup>.

The liquid from the thermostat was supplied to the vertical channel using a pump. Before supplying the liquid into the channel the volumetric flow of the liquid was measured. In the first part of the channel the process of gas and liquid phase mixing occurred using an air distributor. The air was supplied to the distributor by a compressor and its parameters were measured and controlled by a gas flowmeter. In the upper part of the channel the separation of the gas phase from the mixture occurred with its simultaneous supplying to the atmosphere. The liquid was directed to a vertical pipe of a height equal to 1.5 m so as to attain the separation of the gas phase and, next, it was returned to the thermostat. The superficial gas and liquid flow velocities used in the experiment changed from 0.025 to 0.63 m/s and from 0.09 to 1.37 m/s respectively. Whereas the continuous phase was water, the air was the dispersed phase.

The minichannel was made of polycarbonate, which allowed to observe structures of two-phase gas-liquid flow. The two-phase mixture flowing in the channel was recorded using a quick camera MV-D752 – 160 (Photonfocus) with a frequency of 314 frames per second and, subsequently, saved on the hard disc of a computer. Due to the considerable film speed of the camera the photographs taken were clear which allowed to carry out accurate observations and to precisely define the structure of the flow. The identification of the flow patterns was performed off-line. The camera was mounted on a tripod, at a distance of 15 cm from the wider wall of the channel. Such a location of the camera as well as the dimensions of the channels brought about the fact that the structures registered were two-dimensional in practice. The gas phase share in the flowing two-phase mixture was determined on the grounds of the recorded image of the flow using the method presented in the study (Sowiński and Dziubiński, 2009; Tomczak and Sowiński, 2007).

### 4. DOMAIN

The computational domain was prepared for the existing minichannel with a dimension of 320x15x0.8 mm. A simplified construction of the minichannel in both sections is presented in Fig. 1. The most simplified one was in a minichannel inlet zone whose only task was creating a stochastic process condition (uniqueness of forming “bubbles” of gas phase).

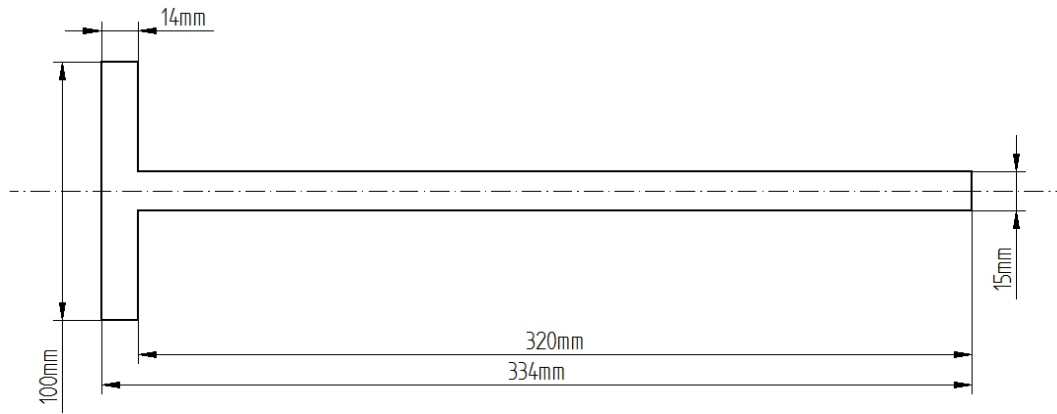

Fig. 1. Minichannel cross-section with dimensions (mm)

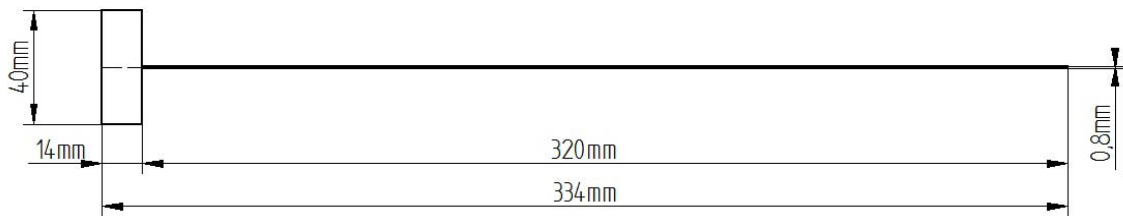

Fig. 2. Minichannel longitudinal section with dimensions

While creating a three-dimensional computational domain, the symmetry of the channel relative to the plane shown in Fig. 1 can be assumed. It was done due to the channel width being small enough (0.8mm) so that the minichannel wall influence does not allow a parallel flow of two bubbles of gas.

Based on Fig. 1, Fig. 2 and the construction of the minichannel (Tomczak and Sowiński 2007, Sowiński and Dziubiński 2009), a three-dimensional computational domain was constructed. Furthermore, an air inlet was built, as 5 square inflows of side length 0.8mm. The final construction of the computational domain is presented in Fig. 3.

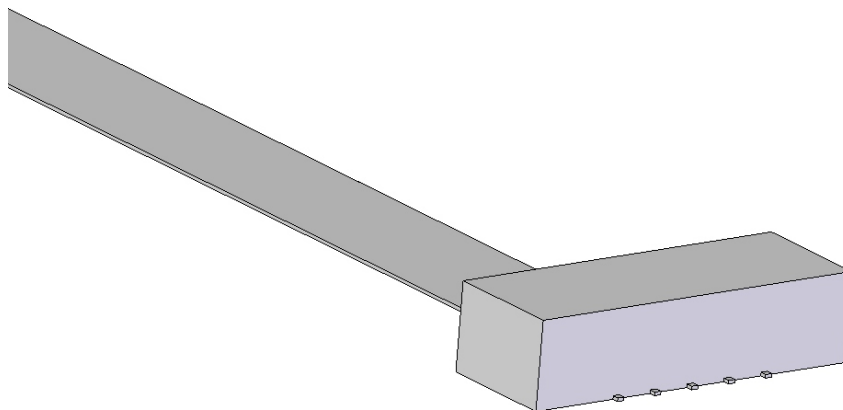

Fig. 3. Computational domain built based on minichannel construction

## 5. MESH AND BOUNDARY CONDITION TYPES

Discretisation of the computational domain was performed in ANSYS Meshing 12 software. Although the mesh is made of orthogonal elements, wedge type elements were also used, especially in the inlet. The mesh consists of 29720 cells (97485 faces). Since the most important part is the minichannel itself, the orthogonal mesh was built on it with the following number of elements: 15x320x4 (width x height x depth). The final computational mesh is shown in Fig. 4.

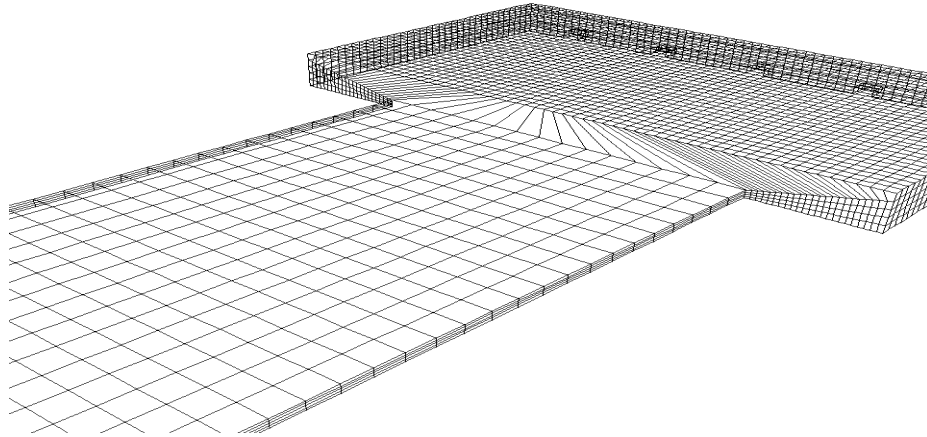

Fig. 4. Mesh for three-dimensional computational domain

The types of boundary conditions applied to the presented computational domain were as follows:

- gas and liquids inlets boundary condition type is mass flow inlet – mass flow defined parameters of the experiments.
- minichannel walls of a boundary condition type is a wall including a contact angle on the wall,
- outlet boundary condition type is pressure outlet – it gives one the possibility to set the pressure relative to the reference value (in this case atmospheric pressure),
- minichannel plane of symmetry boundary condition type is symmetry.

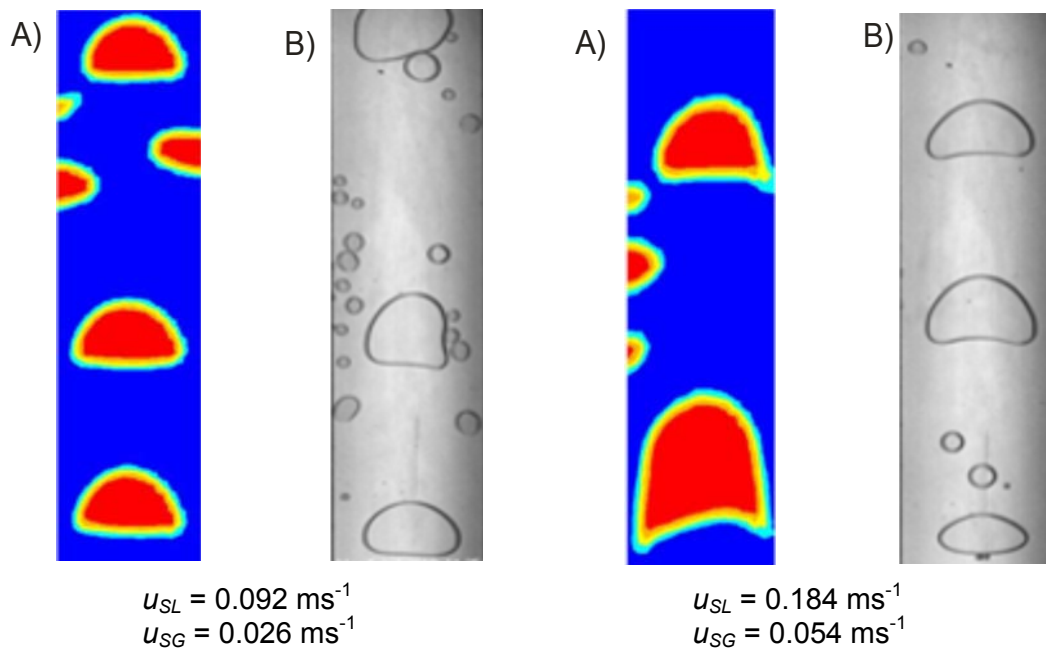

Fig. 5. Comparison of the results of simulations (A) with the pictures determined in the course of the experimental investigations (B)

### 6. RESULTS AND DISCUSSION

The numerical simulations were performed to compare the values measured experimentally with those obtained by numerical calculations. Below is shown a sample picture of two-phase flow simulation of air-water and image recorder in the course of the experimental studies.

Due to the computational grid in the near wall regions, where phases velocity gradients values are the greatest, the predictive representation is not perfect. Therefore at this stage of research, average values were used to compare the results. To determine the average volume fraction of a gas phase, a control surface normal to the flow in the minichannel at the height of 24 cm from the start of channel was used, which represented the center of the frame in experimental studies (Tomczak and Sowiński, 2007). It was assumed that the steady state of the flow in the channel was achieved after 1 s. The next step was to perform a flow simulation for the next 3 s, which was used for collecting results. Then one compared the average values by the numerical calculations with the average values obtained experimentally. To achieve a two-phase flow in the channel model proposed by Zuber-Findley, the following equation was applied (Dziubiński, 2005) as follows:

$$\frac{u_{SG}}{\varepsilon_G} = C_0 \cdot u_{TP} + v_{dr} \tag{3}$$

To describe the two-phase flow in mini- and microchannels the following equation, proposed by Hibiki and Mishima is used (Ide and Fukano, 2005; Mishima and Hibiki, 1996) was used

$$\frac{u_{SG}}{\varepsilon_G} = C_0 \cdot u_{TP} \tag{4}$$

where distribution parameter  $C_0 = 1.32$ .

Then the values obtained experimentally and by numerical simulation were compared with results obtained from Equation (4). The results of this comparison are shown in the following diagram (Fig. 6).

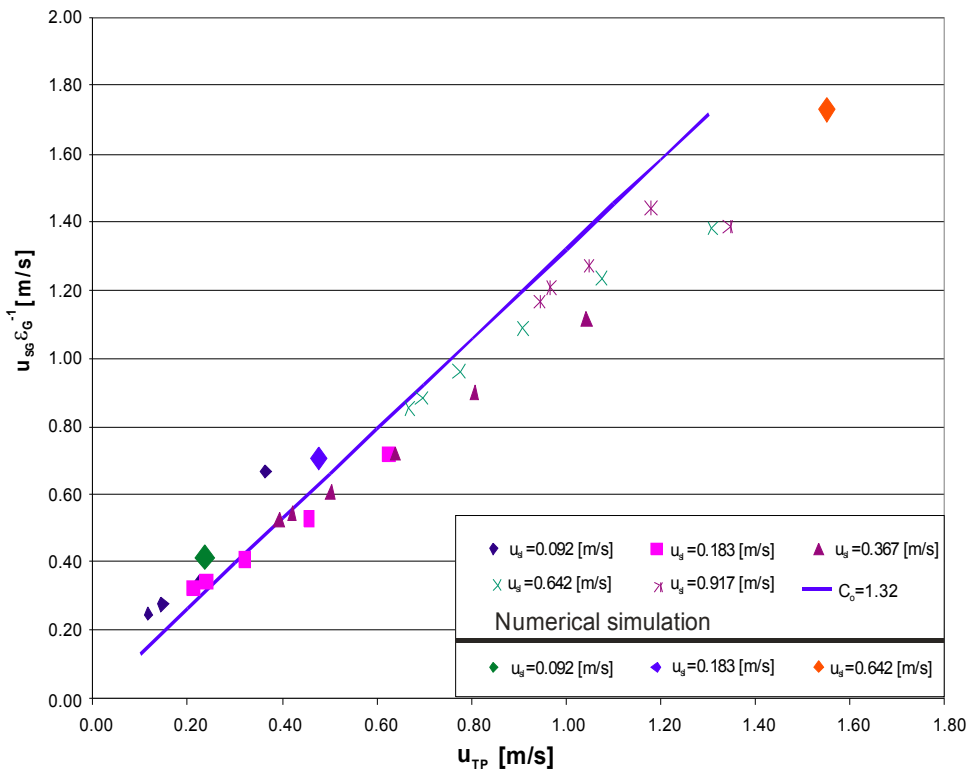

Fig. 6. Dependence of average gas phase velocity  $u_{SG}/\varepsilon_G$  upon velocity of a two-phase mixture  $u_{TP}$ , for the channel of a slot thickness 0.0008 mm, in the course of a two-phase mixture: water-air

It can be noticed that the results of the numerical simulation describe well the experimental results and both of them are similar to those described by Equation (4). In the case of simulation for a large superficial velocity the description error is significantly increased. The reason for a greater error is probably the fact that the mesh elements of the computational domain were not small enough.

## 7. SUMMARY

A numerical simulation of a two-phase gas-liquid flow in the minichannel using ANSYS and FLUENT 12 a VOF built-in model was done. Discretisation of the computational domain was done in ANSYS Meshing 12. The mesh consisted of 29720 orthogonal and wedge cells. The numerical simulation results were compared with the experimental data and acceptable accuracy of description was attained. The numerical calculation results were compared with our own experimental data. An acceptable accuracy of description of the two phase flow pattern and superficial velocities of the phases in the two-phase flow in the minichannel were obtained.

## SYMBOLS

$C_0$	distribution parameter,
$F$	additional forces (ex. including surface tension between phases), kgm/s <sup>2</sup>
$g$	gravitational acceleration, m/s <sup>2</sup>
$\dot{m}_{ij}$	mass transfer from phase j to phase i, m/s
$\dot{m}_{ji}$	mass transfer from phase i to phase j, m/s
$p$	momentum, kgm/s
$S$	source term, mass source, m/s
$u_{SG}$	gas superficial velocity, m/s
$u_{TP}$	two-phase superficial velocity, m/s
$\vec{v}$	mixture velocity, m/s
$\vec{v}_i$	i-phase velocity vector, m/s
$v_{dr}$	drift velocity, m/s

### Greek symbols

$\varepsilon_G$	gas void fraction,
$\varepsilon_i$	void fraction of i-th phase,
$\mu$	mixture viscosity, Pas
$\rho$	mixture density, kg/m <sup>3</sup>
$\rho_i$	phase i density, kg/m <sup>3</sup>

## REFERENCES

- Dziubiński M., 2005. *Hydrodynamics of two-phase flow mixtures of liquid-gas*, Wydawnictwo Politechniki Łódzkiej, Łódź (in Polish).
- FLUENT Release 12.1, 2009. *Manual*, Ansys Inc.
- Ide H., Fukano T., 2005. Experimental research on the correlations of holdup and fractional pressure drop in air-water two-phase flow in capillary rectangular channel. *Exp. Therm. Sci.*, 29, 833-841. DOI: 10.1016/j.expthermflusci.2005.03.010.

- Mishima K., Hibiki T., 1996. Some characteristics of air-water two-phase flow in small diameter vertical tubes. *Int. J. Multiphase flow*, 22, 703-712. DOI: 10.1016/0301-9322(96)00010-9.
- Pohorecki R., Kula K., 2008. A simple mechanism of bubble and slug formation in Taylor flow in microchannels. *Chem. Eng. Res.Des.*, 86, 997-1001. DOI: 10.1016/j.cherd.2008.03.013.
- Qian D., Lawal A., 2006. Numerical study on gas and liquid slugs for Taylor flow in a T-junction microchannel. *Chem. Eng. Sci.*, 61, 7609-7625. DOI: 10.1016/j.ces.2006.08.073.
- Raghvendra G., Fletcher D.F., Haynes B.S., 2009. On the CFD modelling of Taylor flow in microchannels. *Chem. Eng. Sci.*, 64, 2941-2950. DOI:10.1016/j.ces.2009.03.018.
- Santos R.M., Kawaji M., 2010. Numerical modeling and experimental investigation of gas-liquid slug formation in a microchannel T-junction. *Int. J. Multiphase Flow*, 36, 314-323. DOI: 10.1016/j.ijmultiphaseflow.2009.11.009.
- Sowiński J., Dziubiński M., Fidos H., 2009. Velocity and gas-void fraction in two-phase liquid-gas flow in narrow mini-channels. *Arch. Mech.*, 61, 29 – 40.
- Tomczak Ł., Sowiński J., 2007. Application of image analysis to determine two-phase liquid- gas flow parameters in narrow minichannels. *Chem. Process Eng.*, 28, 1134-1156.

*Received 27 September 2011*

*Received in revised form 02 January 2012*

*Accepted 02 January 2012*