

METHOD OF CONVECTIVE VELOCITY DETERMINATION FROM DISSIPATIVE RANGE OF ENERGY SPECTRUM

Tomasz Kurasiński, Czesław Kuncewicz*, Jacek Stelmach

Technical University of Lodz, Faculty of Process and Environmental Engineering,
ul. Wólczańska 213, 90-924 Łódź, Poland

In the study a new proposal of convective velocity determination necessary for eddy size determination from the dissipative range in a turbulent flow in a mixer was made. The proposed quantity depends on all the mean and fluctuating velocity components. By applying convective velocity one may determine the distribution of time and linear Taylor microscale in a stirred vessel.

Keywords: turbulent flow, dissipative range, eddies

1. INTRODUCTION

In a turbulent flow a cascade energy transport occurs from the greatest eddies to the smallest ones where one may observe a total viscous dispersion of kinetic turbulent energy. This means that each eddy size corresponds to a definite part of total energy. The energy of all eddies participating in such a flow forms a turbulence energy spectrum expressed as a function of the wave number due to the periodical and poly-harmonic character of pulsation changes.

The function of energy spectrum may be divided into several less or more visibly separated zones governed by distinct laws. Taking into consideration two-phase gas-liquid flows the most intriguing zone of three-dimensional energy spectrum is the dissipative range. In this region the energy is transferred from larger eddy structures to smaller ones without energy losses. This range is described by Taylor's hypothesis concerning 'the frozen eddy structure'. The onset of dissipative area is represented by Brodkey's eddy range whereas the end corresponds to the range of Taylor's eddies and the slope of a three-dimensional spectrum of turbulence energy in this area is equal to $-5/3$. The content of Taylor's hypothesis is unequivocally expressed with Equations (1) and (2):

$$A_{ii} = U_{conv} \cdot T_{ii} \quad (1)$$

$$\lambda_{ii} = U_{conv} \cdot \tau_{ii} \quad (2)$$

From the above dependencies it follows that the time scales of turbulence (T_{ii} , τ_{ii}) are connected with the spatial scales of turbulence ($A_{ii,k}$, $\lambda_{ii,k}$) by convective velocity U_{conv} . In literature there is no unequivocal definition of this value and, as a standard, the value U_{conv} depends on mean velocities \bar{U}_i and mean fluctuating velocities \bar{u}_i (bottom index "i" concerns the direction of coordinates $i = 1, 2, 3$). When mean velocities in both directions are equal to 0 an equation was proposed by Wu and Patterson (1989) and Kresta and Wood (1992):

$$U_{conv}^2 = \bar{U}_1^2 + \bar{u}_1^2 + \bar{u}_2^2 + \bar{u}_3^2 \quad (3)$$

*Corresponding author, e-mail: kuncewic@wipos.p.lodz.pl

For a full three dimensional flow ($\overline{U}_1 \neq \overline{U}_2 \neq \overline{U}_3 \neq 0$) the above equation acquires a more complex form:

$$U_{conv}^2 = \overline{U}_1^2 + 2 \cdot \overline{U}_2^2 + 2 \cdot \overline{U}_3^2 + \overline{u}_1^2 + 2 \cdot \overline{u}_2^2 + 2 \cdot \overline{u}_3^2 \quad (4)$$

In the literature (Wernersson and Trägårdh, 2000) one also encounters other forms allowing to determine velocity U_{conv}

$$U_{conv}^2 = \overline{U}_1^2 + 5 \cdot \overline{u}_1^2 \quad (5)$$

$$U_{conv}^2 = \overline{U}_1^2 + \overline{u}_1^2 + 4 \cdot \overline{u}_2^2 \quad (6)$$

Equations (3) – (6) show that the distinguished direction signed with index “1” is the main direction of the liquid flow. For the flow in a pipe, for instance, this direction will be one parallel to the pipe’s axis. However, no such direction practically exists in a three-dimensional flow in a stirred vessel. Therefore, there is a need to find a new way of defining this quantity for specific flow of liquid in the tank in which the predominant direction does not exist.

2. INVESTIGATIONS

2.1. Aim of study

Taking the above into account, the aim of the study was to find a new method of determination of convective velocity U_{conv} from the dissipative area of a three-dimensional energy spectrum. Determination of value U_{conv} allows for further and easier calculations of spatial scales A_{ii} and λ_{ii} from Brodkey and Taylor’s ranges (having at one’s disposal the earlier calculated values of time scales T_{ii} , τ_{ii} based on transformations of instantaneous velocities (Kurasiński, 2007)).

In case of two-phase gas-liquid flow analysis one may find particularly useful local Taylor’s scales λ_{ii} attaining values in millimeters and comparable to a gas bubble size during aeration with a sparger or using the construction of self-aspirating impellers (Kurasiński, 2007; Stelmach, 2000). Hence it was decided in the study to focus on investigations of eddies from Taylor’s range. A mixer with a self-aspirating impeller capable of creating a two-phase gas-liquid system without any additional elements installed in the tank (e.g. a sparger) disturbing the flow in the stirred vessel was chosen as an object of study.

2.2. Theoretical part

Due to the lack of a physical interpretation of convective velocity U_{conv} it was decided to base our consideration on investigation of dimensional analysis of the appropriate equations taking as a starting point the assumption that similarly to the existing proposals (Wernersson and Trägårdh, 2000; Wu and Patterson, 1989), the convective velocity should be the function of both mean velocity and the root mean square of fluctuating velocity (RMS).

The starting point was an analysis of equations defining the local rate of energy dissipation ϵ . The classical equation (7) defining the energy dissipation rate indicates that the value ϵ is proportional to the local mean fluctuating velocity (RMS) raised to the third power. It is inconvenient to apply Equation (7) as it is essential to know a dimensionless coefficient C determined experimentally which depends on the flow geometry. In case of self-aspirating disk impellers the value of this coefficient is equal to $C = 5.7 \pm 0.3$ (Kania, 2004).

$$\varepsilon = C \cdot \frac{\bar{u}^3}{D} \quad (7)$$

Simultaneously, the value ε is connected with Taylor and Brodkey's spatial scales and in the analysis of a locally isotropic flow (Nishikawa et al., 1976) the classical Equation (8) is valid and it is given by:

$$\varepsilon = \frac{30 \cdot \nu \cdot \bar{u}^2}{\lambda_{ii}^2} \quad (8)$$

If one considers Equation (2) in Equation (8) one obtains the equation combining the energy dissipation rate with convective velocity U_{conv} .

$$\varepsilon = \frac{30 \cdot \nu \cdot \bar{u}^2}{(U_{conv} \cdot \tau_{ii})^2} \quad (9)$$

As follows from Equation (9) $\varepsilon \propto \bar{u}^2$ was obtained being contradictory to Equation (7). To attain the equality of power exponents at \bar{u}^2 Equation (9) may be defined in a slightly changed form making convective velocity U_{conv} dependent on a mean fluctuating velocity in the power -0.5, $U_{conv} \propto \bar{u}^{-0.5}$

$$\varepsilon \propto \frac{30 \cdot \nu \cdot \bar{u}^2}{(C_\varepsilon \cdot \bar{u}^{-0.5} \cdot \tau_{ii})^2} \quad (10)$$

The coefficient C_ε introduced to Equation (10) must be dimensional and its value may be dependent on the remaining variables which have not been considered so far. Taking into consideration the fact that the energy dissipation rate in the stirred vessel should be dependent on the basic process parameters i.e. N and D it was assumed that the product of those two variables should be present in an equation defining the value of coefficient C_ε as the product $N \cdot D$ which is proportional to the linear velocity of the tip impeller blade. Therefore, assuring the consistence of the units one obtains the following dependence:

$$\varepsilon \propto \frac{30 \cdot \nu \cdot \bar{u}^2}{\left[(N^{1.5} \cdot D^{1.5} \cdot \bar{u}^{-0.5}) \cdot \tau_{ii} \right]^2} \quad (11)$$

The value of the main stream U_{conv} , apart from the fluctuating velocity, is also influenced by the mean velocity in the mixing vessel (which is indicated by Equations (3) – (6)), whose contribution may be determined for instance in a form of classical dependence of turbulence intensity I_t defined by Equation (14) as a ratio of a mean fluctuating velocity $\langle \bar{u} \rangle$ (the mean value RMS for the whole mixer) to mean liquid velocity in the mixer $\langle \bar{U} \rangle$. Introducing the value I_t to Equation (11) one finally obtains:

$$\varepsilon = \frac{30 \cdot \nu \cdot \bar{u}^2}{\left[I_t^{-1} \cdot (N \cdot D)^{1.5} \cdot \bar{u}^{-0.5} \cdot \tau_{ii} \right]^2} = \frac{30 \cdot \nu \cdot \bar{u}^2}{(U_{conv} \cdot \tau_{ii})^2} \quad (12)$$

In this way the velocity of the main stream U_{conv} has been made dependent on the mean and fluctuating velocity and on equipment – process parameters in the form of Equation (13) being as follows:

$$U_{conv} = \frac{(N \cdot D)^{1.5}}{I_t \cdot \sqrt{\bar{u}}} \quad (13)$$

where I_t denotes the mean turbulence intensity in the whole tank.

$$I_t = \frac{\langle \bar{u} \rangle}{\langle \bar{U} \rangle} \quad (14)$$

The essential modification and advantage of the equations derived in such a way is the lack of any experimental coefficients and their symmetry in respect of all spatial directions.

2.3. Experimental

The starting point for the analysis of turbulent field structure was the measurements of mean velocity and mean fluctuating velocity distribution (RMS) inside the stirring vessel. The main element of the experimental stand was a glass, flat-bottomed, cylindrical tank of diameter $T = 292$ mm with an axially mounted self-aspirating disc impeller of diameter $D = 125$ mm and height $h_i = 12,5$ mm located at the level $h = 62$ mm over the bottom. The tank with four standard baffles of width $0.1 \cdot T$ was filled with water to the height $H = T$. A more detailed description of the experimental stand could be found in the work of Kurasiński and Kuncewicz (2009). Measurements were performed for impeller rotation frequency $N = 365 \text{ min}^{-1}$ which corresponds to the Reynolds number $Re = 95050$. The frequency was only slightly greater than the critical frequency $N_{cr} = 335 \text{ min}^{-1}$ ($Re = 87240$) being the starting point (Kurasiński, 2007) for self-aspiration for this diameter of a self-aspirating disc impeller. For this rotation frequency of the impeller the amount of aspirated air from above the surface of liquid to the inside of the tank is very small and it does not change the flow hydrodynamics inside the mixing vessel. However, even a slight quantity of a gaseous phase impedes the measurement of instantaneous velocity as the system LDA is not capable of distinguishing between the gaseous and liquid phases. Therefore, to eliminate gas phase influence on the results of measurements we carried out all the measurements with closed air holes on the surface of the shaft this way attaining one phase liquid flow inside the mixer.

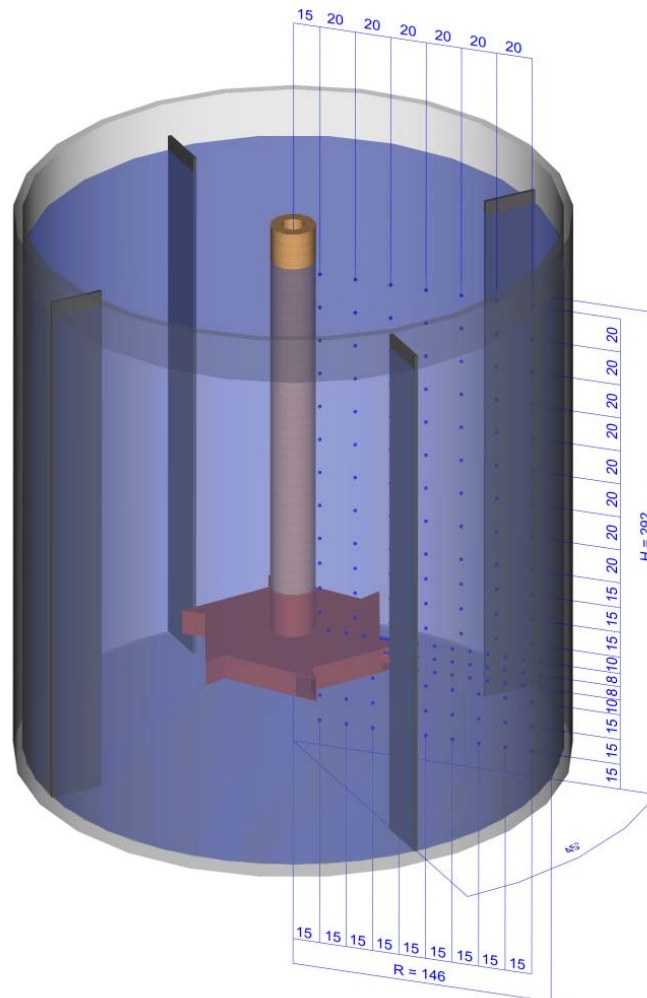

Fig. 1. Experimental points distribution inside the tank with self-aspirating disk impeller

The measurements of instantaneous velocities were performed using a Doppler laser anemometer (DANTEC®) equipped with a laser of power 100 mW (wavelength 514.7 nm) and signal processor BSA T58N10. The measurements of instantaneous velocities were performed in a radial – axial plane located at equal distances from the baffles in about 180 of its points. A detailed distribution of the measurement points inside the tank is presented in Figure 1. The same figure shows the construction of a self-aspirating disc impeller (Kurasiński, 2007; Kurasiński and Kuncewicz, 2009). Due to the importance of the area adjacent to the impeller's zone the greatest number of experimental points was located at the impeller level and the distance between the measurement points in this area in a radial direction was only 2 mm (the bright area at the impeller's suspension height in Figure 1).

Velocity measurements were performed for three directions: for a radial, axial and tangential one changing the location of the optical axis of the laser emitter. Tangential and axial velocity components were measured through a side wall (rotation of coherent beam plane by 90° caused a change of the measured component) whereas the radial component was measured through a mixer bottom. To eliminate the influence of the vessel wall curvature on the location of the laser beam intersection point the mixer was mounted at the glass tank of perpendicular walls filled with water. The sampling frequency was from 0.5 kHz in the neighborhood of liquid surface to 4 kHz in the impeller region. Data acquisition system recorded in each point of the plane 20,000 instantaneous velocities for each velocity components which required the measurement from 4 to 40 s.

3. RESULTS

The experimental data obtained in about 180 points were interpolated for the whole area comprising the measurement plane ($0 \leq r^* \leq 1.0$, $0 \leq h^* \leq 1.0$). The structural grid of the length of the edge equal to 1 mm was applied in a radial and axial direction and in this way 43,071 node points were obtained. To determine the values of mean and fluctuating velocities in all the nodes of calculation grid the numerical interpolation by method of biharmonic spline interpolation was applied (Sandwell, 1987). The method is based on such a selection of polynomial coefficients so that the calculated and measured values are the same in those points of calculation grid in which the experimental value is available.

3.1. Mean and fluctuating velocity distribution in the mixer

Figure 2 shows the experimental results concerning mean circumferential and radial velocities whereas Figure 3 shows mean fluctuating velocity (RMS) for the same directions, for impeller rotation frequency $N = 365 \text{ min}^{-1}$ (Reynolds' number $Re = 95050$). In all the cases particular velocities are expressed in a dimensionless form referred to the velocity of the impeller blade tip.

As follows from the analysis of Figure 2 in the area close to the impeller disc a predominant component is tangential velocity. It is several fold greater than a radial component and about 10-fold greater than an axial component (Kurasiński, 2007). The characteristic (prolonged) velocity profile in the radial direction is observed for the radial component at the impeller level. In this region the liquid is ejected at a high velocity with impeller blades in the direction of vessel wall. The highest values of dimensionless mean velocities for tangential, radial and axial components in the mixer (velocity components divided by velocity of the impeller tip) were 0.8, 0.13 and 0.05 respectively whereas similar values in reference to fluctuating velocities were 0.45, 0.25 and 0.25. It must be underlined that in the region of ca. 10 mm from the tip of impeller blades (in a radial or axial direction) mean values of fluctuating velocities (RMS) for all the spatial directions are similar to one another and are equal to ca. 0.09 m/s (dimensionless value equal to ca. 0.04). The greater distance from impeller blades the smaller values of RMS for particular directions (Kurasiński and Kuncewicz, 2009). This means that turbulence in the

stirred vessel beyond the nearest area of the impeller was isotropic (RMS values for each coordinate direction were similar).

The character of changes of mean and fluctuating velocities along the height and radius of the stirred vessel is in agreement with the data presented in many works (Barailler et al., 2006; Morud and Hjertager, 1996; Wernersson and Trägårdh, 2000; Wu and Patterson, 1989). However, a comparison of numerical values is not possible as the available data concern various constructions of an impeller and a tank.

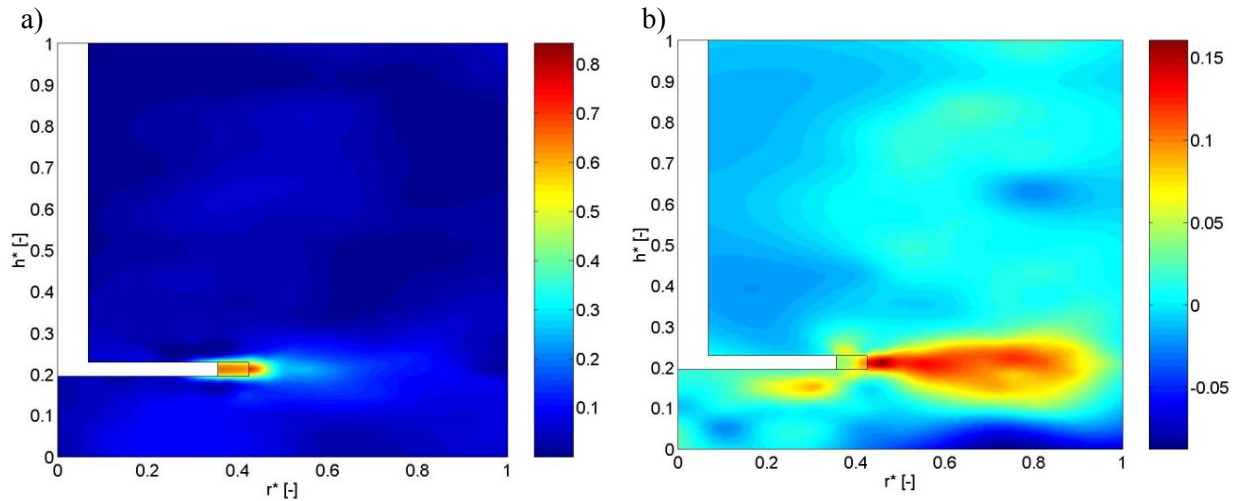

Fig. 2. Mean velocity distribution: a) tangential component, b) radial component

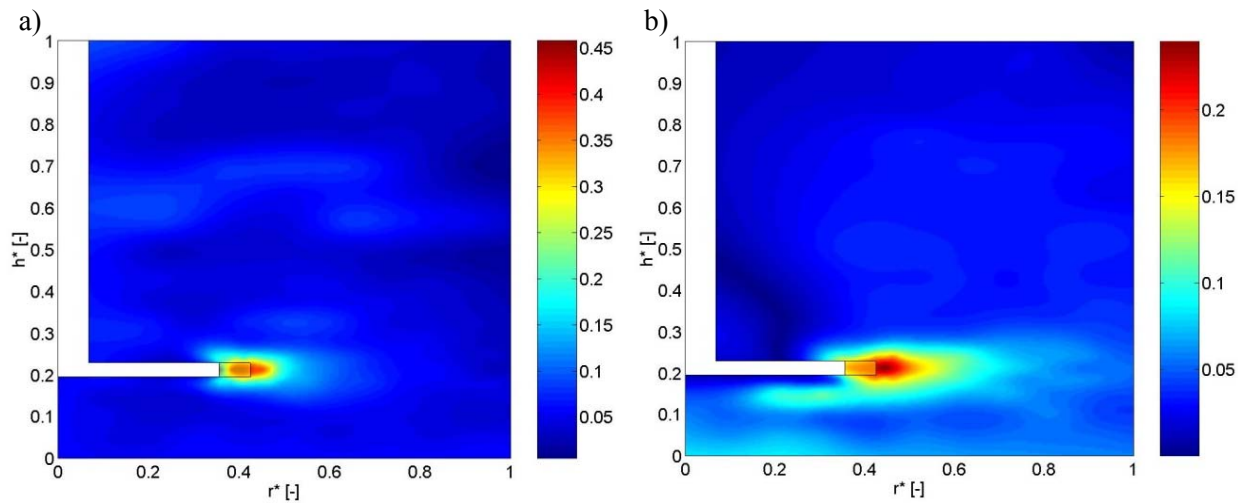

Fig. 3. Dimensionless fluctuating velocity distribution: a) tangential component, b) radial component

3.2. Time and spatial microscale distribution for eddies from Taylor's range

Defining spatial microscale from Taylor's range λ_{ii} from Equation (2) requires the knowledge of convective velocity distribution U_{conv} and time microscale distribution τ_{ii} inside the vessel.

3.3. Defining convective velocity U_{conv}

Equations (12) and (13) derived on the basis of a dimensional analysis allow to determine the local value of convective velocity U_{conv} . However, correctness of the above derivation must be verified

experimentally. This may be performed comparing the local values of energy dissipation rate ε obtained on the basis of the classical Equation (7) and Equations (12) and (13).

Figure 4 shows the values of ε calculated using both methods and applying for this purpose velocity distributions presented in Figures 2 and 3. Figure 4 shows the values of ε for more than 43000 calculation points in the whole tank.

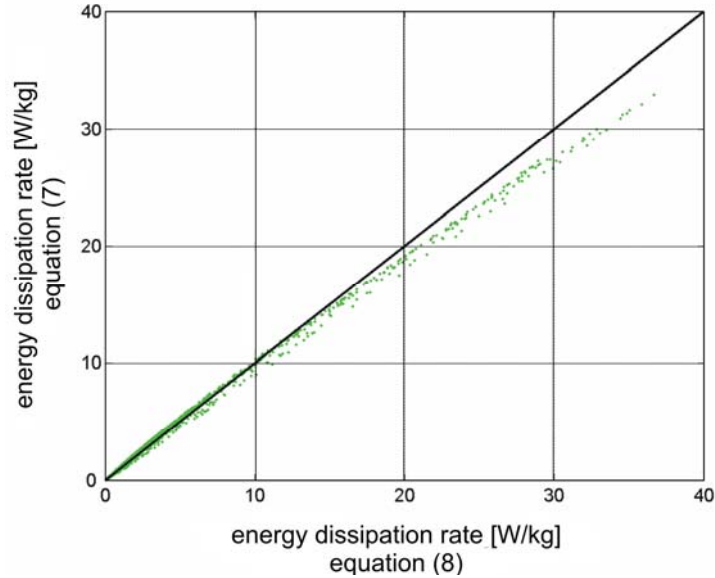

Fig. 4. Comparison of energy dissipation rate ε [W/kg] determined by both independent methods

As follows from the analysis of Figure 4 the greatest differences in values ε calculated using two different methods occur in the area of the impeller blades' tips where values ε are relatively high. However, only about 0.2% of points in Figure 4 (points for $\varepsilon > 5$ W/kg, with mean value of $\langle \varepsilon \rangle$ for the whole mixer equal to 0.277 W/kg) differ considerably from a diagonal and the maximum error was 60%. Nevertheless, the mean error attained the value of only 1.2% for the whole mixer. It is highly probable that errors result from the fact that the starting Equation (4) is valid in the range of homogenous and isotropic turbulence and, as follows from the investigations, turbulence in the region of the impeller's blade is anisotropic (Fig. 3).

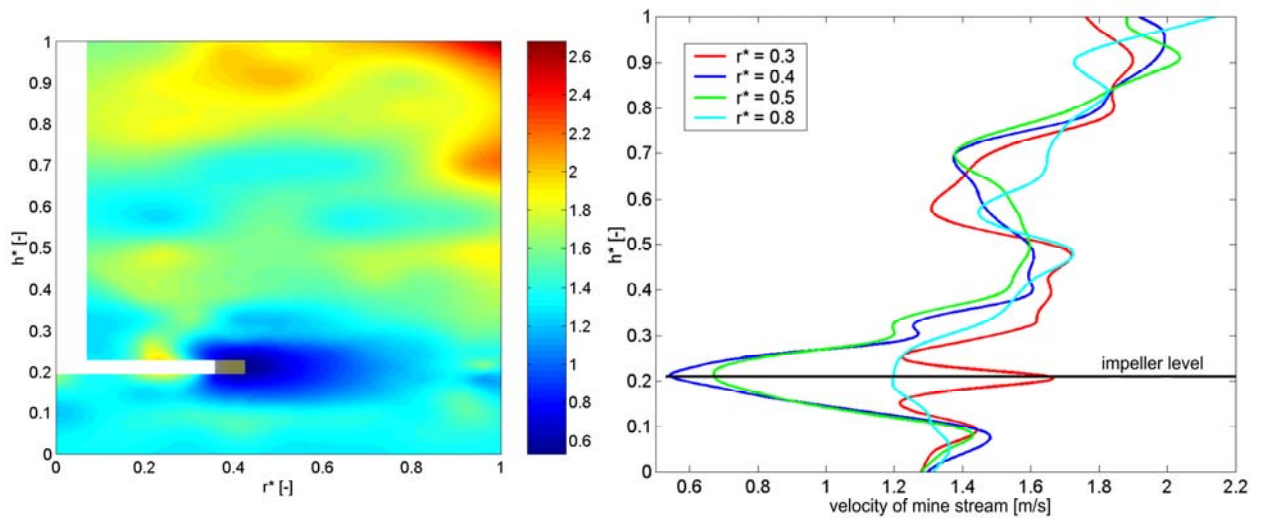

Fig. 5. Distribution of velocity U_{conv} [m/s] along the height and radius of the stirred vessel

The conformity of the values ε calculated using the two methods allowed to apply Equations (12) and (13) derived before for calculation of convective velocity distribution U_{conv} in the whole stirred vessel (Fig. 5).

As follows from Figure 5 the smallest values of U_{conv} may be observed in the region of the impeller's blade (about 0.59 m/s) and the greater is the distance from its edge (in a radial or axial direction) the higher are the values of U_{conv} . In practice, no distribution of function $U_{conv} = f(r^*, h^*)$ along the radius is observed for heights $h^* > 0.4$. Maximum local values of velocity U_{conv} [m/s] exceed maximum mean velocities (Fig. 3) and fluctuating velocities (Fig. 4) indicate that the magnitude U_{conv} constitutes only a parameter of eddy field and on this basis one cannot interpret the phenomena of eddy structure transport inside the tank.

3.4. Defining Taylor's time microscale τ_{ii}

Determination of distribution of Taylor's time microscale τ_{ii} is also a very uphill task and requires resampling signal (instantaneous velocities registered by LDA system) with a constant time step (time intervals of about $5 \cdot 10^{-4}$ s) and calculation of the Fourier transform of the appropriate autocorrelation functions. Distributions of values RMS presented in Figures 2 and Figures 3 were a basis for those calculations and more details on the topic may be found in the work of Kurasiński (2007) and Stelmach and Rzycki, 2002.

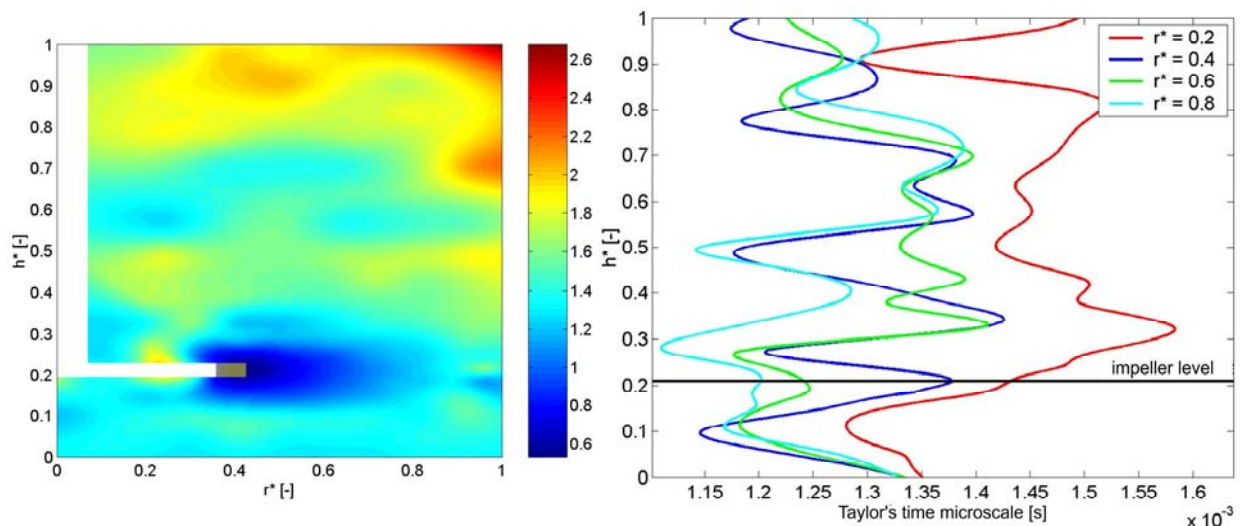

Fig. 6. Distribution of Taylor's time microscale τ_{ii} [s]

In case of Taylor's time microscale τ_{ii} one may observe a visible distribution of its value along the mixer radius and the greatest values are observable in the neighborhood of the impeller's shaft (1.5 ms) and in the region close to vessel wall a mean value of microscale τ_{ii} decreases by 30% in comparison with its maximum value. The influence of impeller blade is unnoticeable. This means that, analogously to convective velocity U_{conv} , the turbulence scale τ_{ii} does not elucidate the transport of eddy structure from the phenomenological point of view and it constitutes only a certain parameter of turbulence field. The explanation of this magnitude with a term of 'eddy life-time' from the onset of dissipative range is not correct as this is only a magnitude resulting from transformation of auto-correlative function. It must be highlighted that Taylor's time microscale in the whole mixer alters to a minor extent from 1.1 to 1.6 ms.

The numerical values of time microscale obtained in the present study may be compared to the data available in the literature only as for the order of a value. For a disc-turbine impeller of diameter $D = 93$ mm and rotation frequency $N = 220 \text{ min}^{-1}$ at the impeller level in paper (Wu and Patterson, 1989) a

mean value of Taylor's time microscale at the level of $\tau_{ii} \cong 0.5$ ms was obtained. In our investigations a mean value of time microscale at the impeller suspension level was 1.2 ms. In the work of Costes and Couderc (1988) the values τ_{ii} in the range of 3.4 – 7.2 ms were attained in the region of Rushton turbine blade for impeller rotation frequencies $75 \text{ min}^{-1} < N < 165 \text{ min}^{-1}$ (in our investigations the value of 1.37 ms was obtained) and as the Authors state (Costes and Couderc, 1988) the value τ_{ii} decreased with an increase of impeller rotation frequency.

3.5. Determination of spatial microscale distribution λ_{ii}

Determination of the main stream velocity U_{conv} allows for a direct determination of spatial turbulence scales from Taylor and Brodkey's range. Figure 7 shows distributions of values of Taylor's spatial microscale λ_{ii} calculated using Equation (2).

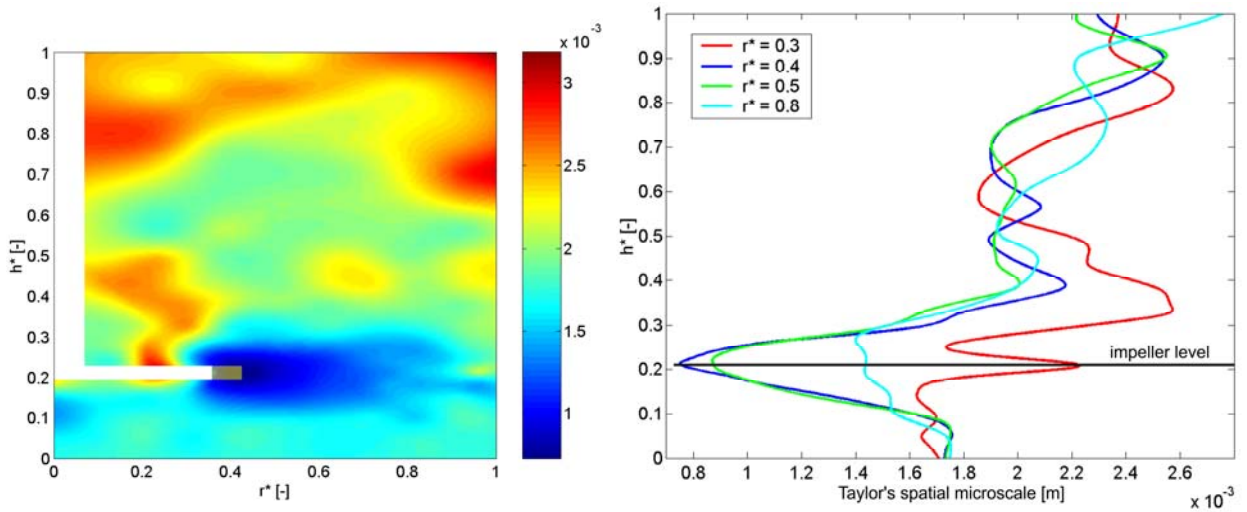

Fig. 7. Distribution of Taylor's spatial linear microscale λ_{ii} [m]

In case of spatial microscale λ_{ii} one may observe a visible influence of the impeller blade as in the region of its edge there is a minimum (0.72 mm) with a mean value in the whole tank equal to 2.01 mm. For the height $h^* > 0.4$ there is no visible influence of the impeller blade and its mean value along the height above the impeller disc is at the level of 2.2 mm. Local values of microscale in the range from 0.7 to 3.2 mm may be easily imagined and this allows to analyse the process of eddy structures transport from the phenomenological point of view. However, one must be aware that this is an oversimplification of the whole phenomenon which has not been thoroughly investigated so far.

The authors of the aforementioned work (Wernersson and Trägårdh, 2000) determined the values of Taylor's longitudinal spatial microscale λ_f in the range from 1 mm to 7 mm depending on the place in the mixer and the way of calculations, the higher values occurring in the impeller zone. This is not in conformity with Taylor's microscale interpretation as an increase of RMS value in the impeller region causes a displacement of energy spectrum in a direction of higher wave-numbers. In this connection, the values of Taylor's microscale λ_{ii} must decrease. Such an interpretation is confirmed by the results in Costes and Couderc's paper (1988) where an increase of impeller rotational speed causes a decrease of Taylor's microscale values λ_{ii} . Nobach (1998), Nobach et. al. (1998) and Broersen et al. (2000) applied a similar method of analysing turbulent fields.

Irrespective of the differences in a precise evaluation of eddy microscale size from the Taylor range provided by particular authors, their size coincides with the air bubble size in the course of liquid aeration in mixers independently of the way of aeration. To exemplify, in the work of Stelmach (2000) the mean value of Sauter diameter $d_{32} = 2.45$ mm was obtained in the diameter's range from 1.05 mm

to 4.5 mm for a self-aspirating disc impeller of rotations $N = 365 \text{ min}^{-1}$. This is in good conformity with the values of Taylor's linear microscale λ_{ii} presented in Figure 7 for the same rotation frequency of the impeller. Similar values of diameters d_{32} for turbine impellers with sparging aeration may be found in other papers (Alves et al., 2002; Laakonen et al., 2005; Martin et al., 2008).

Conformity between microscale size λ_{ii} and bubble diameter's size in the aerated liquid allows to assume that eddy size from the Taylor's range plays a crucial role in the mechanisms of mass transfer in a gas-liquid system in mixers.

4. CONCLUSIONS

1. The proposed new way of determination of convective velocity U_{conv} in the mixer allows to calculate a local value of energy dissipation rate ε inside the mixer for regions characterized by isotropic turbulence.
2. The size of Taylor's spatial microscale λ_{ii} for a self-aspirating disc impeller operating in one-phase system varies from 0.7 to 3.2 mm (the mean value is equal to 2.01 mm) and this value is in agreement with the air bubble size in the stirred tank.
3. Taylor's time microscale τ_{ii} in the same system varies from 1.1 to 1.6 ms and the smallest values are to be observed near the impeller blades.
4. The relationship defining convective velocity of eddy structures U_{conv} from a dissipative range has been introduced only on the grounds of a dimensional analysis and it requires further verification.

The work was carried out in the frames of W-10/1/2011/Dz.St.

SYMBOLS

D	impeller diameter, m
d_{32}	Sauter diameter of air bubbles, m
H	liquid height in the tank, m
h	current height in the mixer, m
h^*	relative height in the mixer = h/H
N	impeller rotational frequency, s^{-1}
R	tank radius, m
r	radius, m
r^*	relative radius = r/R
T	tank diameter, m
U_{conv}	convective velocity from the Taylor and Brodkey ranges, m/s
\overline{u}	mean fluctuating velocity = RMS, m/s
$\langle x \rangle$	mean value for the whole mixer

Greek symbols

ε	energy dissipation rate, W/kg
L_{ii}	linear macroscale of eddies from Brodkey range, m
λ_{ii}	linear microscale of eddies from Taylor range, m
λ_f	longitudinal microscale, m
T_{ii}	time macroscale of eddies from Brodkey range, s
τ_{ii}	time microscale of eddies from Taylor range, s

REFERENCES

- Alves S.S., Maia C.I., Vasconcelos J.M.T., Serralheiro A.J., 2002. Bubble size in aerated stirred tanks. *Chem. Eng. J.*, 89, 1-3, 109-107. DOI: 10.1016/S1385-8947(02)00008-6.
- Barailler F., Heniche M, Tanguy P., 2006. CFD analysis of a rotor-stator mixer with viscous fluids. *Chem. Eng. Sci.*, 61, 9, 2888-2894. DOI: 10.1016/j.ces.2005.10.064.
- Broersen P.M.T., de Waele S., Bos R., 2000. The accuracy of time series analysis for laser-Doppler velocimetry, *10th International Symposium on Application of Laser Technique to Fluid Mechanics*. Lisboa, Portugal, 10-13 July 2000.
- Costes J., Couderc J., 1988. Study by LDA of the turbulent flow induced by a Rusthon turbine in a stirred tank. Spectral analysis and scale of turbulence. *Chem. Eng. Sci.*, 43, 10, 2765-2772. DOI: 10.1016/0009-2509(88)80019-8.
- Kresta S., Wood P., 1993. The flow field produced by a pitched blade turbine: characterization of the turbulence and estimation of dissipation rate. *Chem. Eng. Sci.*, 48, 10, 1761-1774. DOI: 10.1016/0009-2509(83)80346-R.
- Kurasiński T., 2007. *The effect of turbulent field parameters on the mass transport rate for self-aspirating impellers*. PhD Thesis, Technical University of Lodz, Łódź (in Polish).
- Kurasiński T., Kuncewicz Cz., 2009. Determination of turbulent diffusion coefficient in an agitator for self-aspirating impeller. *13th European Conference on Mixing*, London, Great Britain, 14-17 April 2009, on CD-ROM.
- Laakonen M., Honkanen M., Saarenrinne, Aittamaa J., 2005. Local bubble size distribution, gas-liquid interfacial areas and gas holdups in stirred vessel with particle image velocimetry. *Chem. Eng. J.*, 109, 1-3, 37-47. DOI: 10.1016/j.ces.2005.03.002.
- Martin M., Montes F.J., Galan M.A., 2008. Bubbling process in stirred tank reactors I: Agitator effect on bubble size, formation and rising. *Chem. Eng. Sci.*, 63, 12, 3212-3222. DOI: 10.1016/j.ces.2008.03.028.
- Morud K., Hjertager B., 1996. LDA measurements and CFD modeling of gas-liquid flow in a stirred vessel. *Chem. Eng. Sci.*, 51, 2, 233-249. DOI: 10.1016/0009-2509(95)00270-7.
- Nishikawa M., Okamoto Y., Hashimoto K, Nagata L., 1976. Turbulence energy spectra in baffled mixing vessel. *J. Chem. Eng. Japan*, 9, 6, 489-494.
- Nobach H., Müller E., Tropea C., 1998. Efficient estimation of power spectral density laser Doppler anemometer data. *Ex. in Fluids*, 24, 499-509. DOI: 10.1007/s003480050199.
- Nobach H., A., 1998. Global concept of autocorrelation and power spectral density estimation from LDA data sets, *9th International Symposium on Application of Laser Technique to Fluid Mechanics*. Lisboa, Portugal, 13-16 July 1998, paper 32.5.
- Sandwell, David T., 1987. Biharmonic spline interpolation of GEOS-3 and SEASAT altimeter data. *Geophysical Research Letters*, 2, 139-142.
- Stelmach J., 2000. *Investigation of the self-aspirating impellers*. PhD Thesis, Technical University of Lodz, Łódź (in Polish).
- Stelmach J., Rzycki E., 2002. The application of sample and hold method in the processing of data obtained from a laser Doppler anemometer. *Intern. Journal of Appl. Mech. Eng.*, 7, 1291-1303.
- Wernersson E., Trägårdh C., 2000. Measurements and analysis of high-intensity turbulent characteristics in a turbine agitated tank. *Exp. in Fluids*, 28, 532-545. DOI: 10.1007/s003480050414.
- Wu H., Patterson G., 1989. Laser-Doppler measurements of turbulent flow parameters in a stirred mixer. *Chem. Eng. Sci.* 44, 10, 2207-2221. DOI: 10.1016/0009(89)85155-3.

Received 21 September 2011

Received in revised form 18 November 2011

Accepted 18 November 2011