

Witold M. LEWANDOWSKI<sup>1</sup>, Ewa RADZIEMSKA<sup>1</sup>,  
Michał RYMS<sup>1\*</sup> and Piotr KUBSKI<sup>1</sup>

**SYSTEMATIC AND SELECTION CRITERIA  
FOR ORC SYSTEM WORKING FLUID  
USED FOR A DETERMINED AMOUNT  
OF EXCESSIVE ENERGY**

**SYSTEMATYKA I KRYTERIA DOBORU  
CZYNNIKA ROBOCZEGO UKŁADU ORC  
DLA OKREŚLONYCH ZASOBÓW CIEPŁA ODPADOWEGO**

**Abstract:** Increasing the efficiency of technological processes is considered as an important element of sustainable development concept in the decrease in greenhouse gas emissions and renewable energy utilization. The following paper reaches out against the market demands, showing ways of contributing into this trend. In technological processes, waste heat energy is often an unsolved problem. Attempts of utilizing that heat, especially in petrochemical industry, have come across many problems, such as low energy level, great dispersement, wide parameter range and the cost-efficiency of potential modernization. One of promising technologies of utilizing this heat is through *Organic Rankine Cycle* (ORC) system implementation. The following paper shows a global approach into the problem of achieving maximum efficiency of ORC. A complex review of thermodynamic fluids, available for use in ORC has been prepared, the fluids has been described in terms of temperature source range, safety of use, price and environmental impact. Guidelines in designing ORC, based on experience in introducing unconventional solutions in industry, are described. According to the results acquired, choosing these installations for excessive heat utilization enables not only an increase in efficiency of technological processes but also elevates the proecological image of the company.

**Keywords:** ORC system, working fluid, excessive heat utilization.

Because of the fact that the thermodynamic parameters of water, a common fluids used in basic power plants, are not satisfactory, especially with low parameters, already in 1960's a search for another fluid available for use in a binary cycle and for utilizing waste energy with the fluid temperature lower than 400 °C has been conducted [1].

---

<sup>1</sup> Department of Chemical Apparatus and Theory of Machines, Chemical Faculty, Gdansk University of Technology, ul. Narutowicza 11/12, 80-233 Gdańsk, Poland, phone: +48 58 347 18 74.

\* Corresponding author: smyr@plusnet.pl

In [1] freon gas usefulness has been pointed out for use as a low-boiling fluid in the, so called, binary power plant, especially in supercritical parameter range, for which positive results of turbine work parameters may be expected.

The increase of interest in low-boiling working fluid occurred again with the development of ORC-based (*Organic Rankine Cycle*) technologies. Because of ORC's low energetic efficiency in comparison with piston and rotor engine based technology, the new developed technology was not put into any use for a long time. However, the possibilities of its implementation in utilizing low temperature unconventional energy sources, especially biomass combustion, have attracted yet another increase of interest in this technology.

This work is dedicated to solving the problem of choosing a proper working fluid for utilizing a given amount of energy.

## Working fluid requirements

Working fluid requirements can be divided into general and specific requirements concerning thermodynamic efficiency of its implementation.

A thermodynamic fluid, being specifically an energy carrier taking part in heat conversion in an ORC system, should generally meet demands similar to those presented for refrigeration and heat pump fluids. The basic requirements for ORC fluids are:

- Chemical stability and durability in the whole heat range;
- High values of supercritical parameters;
- Chemical neutrality against the components of the installation;
- Safety of use – lowest possible toxicity, flammability and explosiveness;
- High volume heat efficiency (in order to apply a small working fluid stream and minimize the installation size);
- Environmental friendliness.

Aside these, ORC fluids should also meet specific thermodynamic requirements described below.

Obviously, fluids which are easiest to obtain are the best choice. These are substances easily produced in oil refining processes, such as propane and butane and its isomers. In order to increase the efficiency of cycle, more and more often synthetic fluids are used, such as one-, two- or multicomponent solutions of hydrocarbons and their derivatives.

## Working fluid systematic

For systemizing a still increasing number of heat fluids (used also in refrigeration cycles), a uniformed system (being now an ISO standard) for classifying working fluids was introduced. The basic rule of this system is chemical structure of the substances as well as, interchangeable, their manufacture names are used.

It became a rule to mark the fluids with a few symbols, derived directly from their structure. This way, few substance groups have been introduced, most known of which are:

- HC – saturated hydrocarbons, substances with no halogenic content;
- FC – organic substances in which all hydrogen atoms in the particle have been replaced with fluorine;
- HFC – hydrofluorocarbons – carbon based compounds in which part of hydrogen atoms have been replaced with fluorine;
- CFC – chlorofluorocarbons halogenic, very stable compounds, organic particle derivatives in which all hydrogen atoms have been replaced with fluorine and chlorine;
- HCFC – hydrochlorofluorocarbons, organic particles in which not all hydrogen atoms were replaced with fluorine or chlorine;
- HBFC – hydrobromofluorocarbons, organic compounds in which bromine atoms are present.

Aside from symbols mentioned above, a code number for each of the fluid may be marked by a single letter, as it is for typical refrigeration compounds (marked with 'R').

Second part of the code is commonly comprised of three or four digits. First number is the number of carbon atoms in a compound, decreased by one. Number 4 describes in this case a nonazeotropic solution, while number 5 – an azeotropic one. In particular cases, number 6 is used for organic compounds and 7 for inorganic. If the number is 0, it is omitted.

Second digit, given the first is in a range of 1–3, describes the number of hydrogen atoms in the particle, increased by one. If the first digit is 4 or 5, the second and third digit are used as a variable describing the solution composition. If the first number is 6, the second number becomes 0 for hydrocarbons, 1 for compounds containing oxygen, 2 for compounds containing sulfur and 3 for nitrogen. If the first number is 7, the second and third numbers are the particle mass indication.

The third digit, given the first ranges from 1 to 3, shows the number of fluorine atoms in a particle.

If there are isomers available, an additional a, b, c etc is placed behind the code number. For example, a working fluid marked as HFC-134a is a compound containing 2 carbon atoms, 2 hydrogen atoms, 4 fluorine atoms and no chlorine atoms. Therefore, its formula is  $C_2H_2F_4$ . This formula can be used for two different isomers:  $CHF_2-CHF_2$  (HCF-134) and  $CH_2F-CF_3$  (HCF-134a). Examples of other compound marking can be found in [2].

It is also important to notice that, especially in the refrigeration industry, an additional marking system is implemented – ie R134a instead of HCF-134a.

## Ecological and safety indicators

In order to assess the impact of work fluids on the environment, two separate adverse phenomena possible to occur with the fluids's release to the atmosphere should be considered – depleting the ozone layer and contribution into the greenhouse effect.

Since 1970's it is known that some of the stable refrigeration agents, such as R11 or R12, permeating into the atmosphere are degraded by UV radiation, causing the depletion of ozone resources. A hazardous concentration of once released freons can sustain in the atmosphere for hundreds of years. Just the same important is the problem of freons absorbing the heat radiation of wavelength  $\lambda = 8\text{--}15 \mu\text{m}$ , the, so called, dispersed sun radiation.

The described above adverse effects of refrigeration fluid use were the reason for conducting research in order to assess the environmental impact of all contemporary and yet to be used work fluids. Three main environment impact indicators have been developed:

- *ODP* – Ozone Depletion Potential – characterizing the impact of a refrigeration fluid on the intensity of ozone decomposition, in relation to that of R11 working fluid:  $ODP_{R11} = 1$ ;

- *GWP* – Global Warming Potential – characterizing the impact of a refrigeration on the greenhouse effect, in relation to the impact of  $\text{CO}_2$  and an exposition time of 100 years;

- *TEWI* – Total Equivalent Warming Impact – used mainly in reference to refrigeration agents, in  $\text{CO}_2$  equivalent tons.

The last of the mentioned parameters (*TEWI*) allows a full assessment on the agent's environmental impact. It takes into account the direct influence of the agent's release into the atmosphere, as well as the indirect result of  $\text{CO}_2$  emission during electric energy production, ie heat pump compressors. It is possible to determine the value of this parameter based on the equation:

$$TEWI = GWP_n + GWP_s + E \text{ [kg CO}_2\text{]}$$

where:  $GWP_n = GWP \cdot L \cdot n$ ,  $GWP_s = GWP \cdot (1 - \alpha_0) \cdot m$ ,  $E = E_a \cdot \beta \cdot n$ ;

*TEWI* – total equivalent of global warming increase in  $\text{CO}_2/\text{a}$ ;

*GWP* – potential of global warming in reference to  $\text{CO}_2$ ;

*L* – annual loss of refrigeration agent caused by leaks, in  $\text{kg/a}$ ;

*n* – device exploitation time, in years,

$\alpha_0$  – measure of agent recycling (range from 0 to 1);

*m* – mass of agent in the installation, in  $\text{kg}$ ;

$E_a$  – annual energy consumption, in  $\text{kWh/a}$ ,

$\beta$  –  $\text{CO}_2$  emission indicator for production of 1  $\text{kWh}$  of energy, in  $\text{kg CO}_2/\text{kWh}$ .

It is important to notice that evaluating the *TEWI* parameter is available only for certain installments, not for specific agents.

Aside from the above indicators, it is worth mentioning the fluids toxicity indicators.

Two groups of toxicity level were created:

- Group A – work fluids which do not have a hazardous influence on employees in direct vicinity being exposed daily to an average concentration of  $400 \text{ cm}^3/\text{m}^3$  or above;

- Group B – work fluids which do not have influence on employees in direct vicinity being exposed daily to an average concentration below  $400 \text{ cm}^3/\text{m}^3$ .

Table 1  
Common thermodynamic working fluids in ORC systems and their comparison factors [3]

No.	Name	Chemical formula	Marking	Molar mass, $M$ [g/mol]	Boiling point, $T_{s,p}$ [K]	Critical parameters				Freezing point, $T_m$ [K]	Vaporization enthalpy, $r$ [kJ/kg]	$T_{s,p} / T_k = T_{lm}$ [-]
						Temperature		Pressure, $p_k$ [MPa]	Volume, $v_k$ [m <sup>3</sup> /kg]			
						$t_k$ [°C]	$T_k$ [K]					
1	Ammonia	NH <sub>3</sub>	R717	17.0	239.7	132.0	405.3	11.33	0.00427	195.4	1347.0	0.591
2	Water	H <sub>2</sub> O	R718	18.0	373.0	373.8	647.0	22.06	0.00315	273.2	2256.0	0.577
3	<i>n</i> -Butane	C <sub>4</sub> H <sub>10</sub>	R600	58.1	272.6	150.8	425.2	3.80	0.00490	135.2	383.8	0.641
4	Isobutane	C <sub>4</sub> H <sub>10</sub>	R600a	58.1	261.3	134.9	408.1	3.65	0.00514	114.0	328.4	0.640
5	<i>n</i> -Pentane	C <sub>5</sub> H <sub>12</sub>	—	72.2	309.2	196.6	469.8	3.37	—	143.4	357.2	0.658
6	Benzene	C <sub>6</sub> H <sub>6</sub>	—	78.1	353.0	289.0	562.2	4.90	—	278.7	438.7	0.628
7	Toluene	C <sub>7</sub> H <sub>8</sub>	—	92.1	383.6	318.6	591.8	4.10	—	178.2	362.5	0.648
8	1,1,1,3,3-pentafluorobutane	CF <sub>3</sub> CH <sub>2</sub> CF <sub>2</sub> CH <sub>3</sub>	R365mfc	148.1	314.5	186.9	460.1	3.25	0.00193	243.2	200.8	0.684
9	1,1,1,2-Tetrafluoroethane	CH <sub>2</sub> F-CF <sub>3</sub>	R134a	102.0	248.0	101.0	374.2	4.06	0.00195	172.2	215.5	0.663
10	Ethylbenzene	C <sub>8</sub> H <sub>10</sub>	—	106.1	411.0	343.0	616.2	3.50	—	178.2	339.9	0.667
11	Dichlorodifluoromethane	CCl <sub>2</sub> F <sub>2</sub>	R12	121.0	243.2	111.8	385.1	4.13	0.00179	115.5	166.1	0.632
12	1,1,1,3,3-Pentafluoropropane	CHF <sub>2</sub> CH <sub>2</sub> CF <sub>3</sub>	HFC-245fa	134.1	288.4	157.5	430.7	3.64	0.00193	166.2	208.5	0.670
13	1,1,2,2,3-Pentafluoropropane	CHF <sub>2</sub> CF <sub>2</sub> CH <sub>2</sub> F	HFC-245ca	134.1	298.2	178.4	451.6	3.86	0.00193	199.8	217.8	0.660
14	Trichlorofluoromethane	CCl <sub>3</sub> F	R11	137.0	296.2	197.8	471.0	4.41	0.00182	162.0	178.8	0.629
15	—	—	HFE-245fa	150.0	—	170.8	444.0	3.73	—	—	—	—
16	1,1,1,3,3,3-Hexafluoropropane	CF <sub>3</sub> CH <sub>2</sub> CF <sub>3</sub>	HFC-236fa	152.0	272.0	130.6	403.8	3.18	0.00180	179.0	168.8	0.674
17	Dichlorotrifluoroethane	CHCl <sub>2</sub> CF <sub>3</sub>	R123	152.9	301.0	183.8	456.9	3.70	0.00182	166.2	171.5	0.659
18	2-Chloro-1,2,2,2-Tetrafluoroethane	CF <sub>3</sub> CHClF	R124	136.5	261.2	122.3	395.5	3.62	0.00179	156.2	146.5	0.660
19	1,2-Dichlorotetrafluoroethane	C <sub>2</sub> Cl <sub>2</sub> F <sub>4</sub>	R114	170.9	276.7	145.7	418.9	3.26	0.00172	179.2	136.2	0.661
20	1,1,2-Trichloro-1,2,2-Trifluoroethane	CCl <sub>2</sub> CFClF <sub>2</sub>	R113	187.0	320.4	214.1	487.3	3.41	0.00174	236.7	143.9	0.658
21	—	CF <sub>3</sub> CH <sub>2</sub> CF <sub>2</sub> CH <sub>3</sub>	SES 36	184.5	308.8	177.6	450.8	2.85	0.00186	—	129.3	0.685
22	<i>n</i> -Perfluoro-Pentane	C <sub>5</sub> F <sub>12</sub>	—	288.0	302.4	147.4	420.6	2.05	—	—	87.8	0.719

Table 1 shows a collection of selected working fluids, categorized according to the systematic mentioned above, with their basic physical properties mentioned. Selected fluids were also shown in Table 2, with their ecological factors.

Table 2

Working fluids and their impact on the environment

Marking	ODP	GWP <sub>100</sub>	Safety group
R717	0.000	<1	B2
R718	0.000	<1	A1
R600	0.000	~20	A3
R600a	0.000	~20	A3
R601	0.000	11	b.d.
R365mfc	0.000	825	b.d.
R134a	0.000	1300	A1
R12	0.820	10600	A1
HFC-245fa	0.000	950	B1
R11	1.000	4600	A1
HFC-236fa	0.000	9400	A1
R123	0.012	120	B1
R124	0.026	620	A1
R114	0.850	9800	A1
R113	0.900	6000	A1
SES 36	0.000	3126	b.d.

The last criterion worth mentioning is the fluid flammability parameter. This category is divided into:

- Group A – fluids non-flammable in any concentration,
- Group B – fluids with a lower flammability limit of 3.5 % (or above) mixture with air,
- Group C – fluids with a lower flammability limit of below 3.5 %.

A comparison of fluids safety groups have been shown in Table 3.

Table 3

General characteristics of working fluids based on their toxicity and flammability

Criterion	Lower toxicity	Higher toxicity
Non-flammability	A1	B1
Lower flammability	A2	B2
Higher flammability	A3	B3

## Division and practical use of working fluids

An increase of interest on low-boiling working fluids has been observed with the development of ORC-based technologies (organic Rankine cycle) [5, 10]. Because of its low energetic efficiency, the ORC systems have not received acclaim and recognition for a long time. But the possibility of selecting this technology for low-temperature

unconventional energy reserve utilization, especially through dumped biomass combustion energy, has caused an increase of interest in this technology.

The Clausius-Rankine Cycle (C-R) is a cycle used in evaluating conventional, organic-fueled, water steam engines, as well as nuclear power plants [4, 11–15]. It can also be used for non-water fluid vapor engines evaluation – these fluids include low-boiling refrigerants (organic oils, freon, hydrocarbons etc). It is this kind of cycle, which is commonly known as Organic Rankine Cycle. Choosing the fluid's thermodynamic properties (like these shown on Belpaire's limit curves – Fig. 1) as a main criteria, three types of organic fluids can be distinguished – wet fluid, dry fluid and an isentropic fluid. This division is based on expansion process of a fluid in dry saturated vapor state in respect to the higher limit curve.

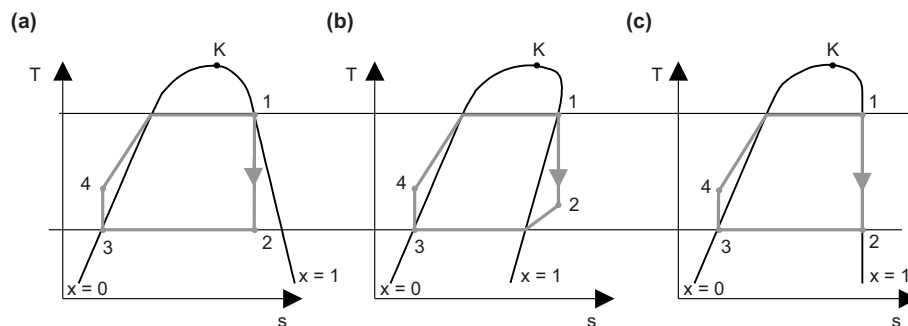

Fig. 1. ORC cycles for different work fluids: (a) wet, (b) dry, (c) isentropic

From a technological point of view, the most convenient type of fluid to use is the so called dry fluid, expansion of which unfolds in the overheated vapor area. This guarantees beneficial turbine work conditions, because the fluid flowing through it does not contain liquid drops.

Schematic diagram of the classical ORC cycle have been shown in Fig. 2 however internal regeneration is commonly introduced if such a fluid is utilized. The regenera-

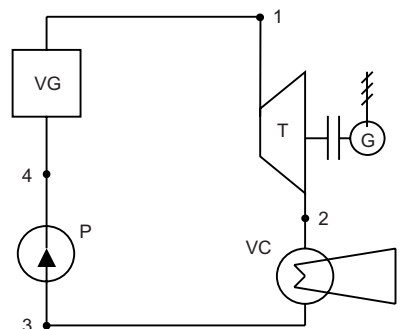

Fig. 2. Basic ORC cycle scheme, VG – vapor generator, T – turbine, G – electricity generator, VC – vapor condenser P – pump

tion is based upon the fact, that the cooling fluid leaving the turbine (in a state of overheated vapor) empowers the heat exchanger (recuperator) before entering a condenser – the heat received in the recuperator is then transferred into the liquid being condensed from vapor in the condenser. Introduction of an internal regeneration causes preliminary heating of the liquid which enters the heat exchanger, in front of which the regeneration heat is utilized.

The ORC cycle in such an arrangement is accomplished through the following line of devices:

- A heat exchanger for heating the working fluid with the use of excessive heat;
- Dry saturated vapor generator, also empowered with excessive heat;
- Turbine, used for expanding the dry saturated vapor into the state of overheated vapor;
- A recuperator (overheated vapor cooler and liquid preheater also);
- A vapor condenser;
- A pump empowering the recuperator and any other further heat exchangers.

### Selection criteria for orc system working fluids

When choosing a work fluid for ORC systems, special attention should be put on few basic criteria deciding whether the system will function properly:

- Jacob's phase shift number  $Ja(T_1)$  for the upper source parameters and respectively, as an equal criteria  $\Delta H(T_2)/h_{1,v}$  relation. According to [4], the ORC efficiency can be described with a following formula:

$$\eta = \frac{\Delta H(T_2)/h_{1,v}}{(c_p T_1 / h_{1,v})\eta_c + 1} = \frac{\Delta H(T_2)/h_{1,v}}{Ja(T_1)\eta_c + 1}$$

where:  $T_1$  – expansion start temperature within the turbine;

$c_p$  – specific heat capacity;

$h_{1,v}$  – phase shift heat;

$\Delta H(T_2) = h_2 - h_3$  (excess of enthalpy in respect to the condenser).

Because the Jacob number is directly proportional to the system's efficiency, It is important to choose a fluid which a possibly high Jacob number. The  $\Delta H(T_2)/h_{1,v}$  relation should be possibly low [4].

- For under-critical cycles, the upper source temperature should be below the critical point.

- The relation of pressure in front of and behind the turbine should be moderate, because it is a factor determining the power of the pump.

- The saturation pressure of the lower source should be a bit higher than atmospheric pressure, enabling the easiness of keeping the installation airtight.

Having the above criteria in mind, it is possible to evaluate whether a work fluid is possible for implementation in a specific cycle. The final choice of a fluid is commonly



based on one additional, often a critical parameter – the price of a given fluid. This factor verifies the cost-efficiency of the whole system.

## Work range and efficiency comparison of working fluids

A number of possible fluids was tested for possible ORC system utilization. Six of the tested fluids were chosen further and their work characteristics under different work parameters have been evaluated. These fluids have been shown in Table 1 and Table 2. The crucial criteria were two work temperature limits, between which an ORC system was to be established. The upper temperature limit was consecutively set on 80, 100 and 120 °C, while the lower – approx. 35 °C. This is an average range of temperatures in an excessive refinery heat utilization process.

A basic Clausius-Rankine cycle (C-R cycle) was examined, with the use of different working fluids. Results of the analysis are shown in Table 4. One should notice the strong influence of temperature range on the basic C-R cycle, based on different fluids. Simultaneously, research on the possibility of using an ORC in lower temperature range has been conducted.

Table 4

C-R cycle efficiency comparison with different working fluids under different temperature limitation

Work fluid name	Mollar mass [kg/kmol]	C-R cycle efficiency (upper source temp.)			Saturation temp. (1 bar pressure) [°C]	Critical point parameters	
		120 °C	100 °C	80 °C		[°C]	[MPa]
SES 36	184.5	0.1681	0.1444	0.1124	35.26	177.55	2.85
R600 ( <i>n</i> -Buthane)	58.1	0.1729	0.1451	0.1111	-0.84	150.80	3.72
R600a (isobuthane)	58.1	0.1691	0.1439	0.1187	-12.20	135.92	3.68
R365mfc*	148.1	0.1543	0.1277	0.1681	40.99	186.85	3.25
R123	152.9	0.1750	0.1462	0.1112	27.20	183.79	3.74
R124	136.5	—	0.1430	0.1103	-12.27	122.22	3.62

\* – end temp. 42 °C because of the negative pressure area.

In this study, an ORC system, working in a temperature range of 73 °C to 32 °C has been examined – this range allows good cooperation of the system with an existing installation. Three different work fluids have been taken into consideration, for which the efficiency calculations in different configurations have been developed.

Firstly, a basic ORC system was examined, after that – a cycle with a heat regenerating exchanger implemented within. Based on the results, a working fluid providing the maximum efficiency within the given temperature range has been chosen. The efficiency of a Carnote cycle for this fluid was  $\Delta\eta_c = 11.84\%$ .

Table 5 lists the calculations for ORC system efficiency. The Jacob number and  $\Delta H(T_2)/h_{1,v}$  value, both also enlisted, were the reference factors. Analysis of the results shows that the use of SES 36 working fluid allows reaching the maximum efficiency of 11.58 %.

Table 5

Results of ORC efficiency calculations with different working fluids [16, 17]

No.	Marking	$Ja(T_1)$ [-]	$\Delta H(T_2)/h_{1,v}$ [-]	Basic ORC efficiency, $\eta_{ORC}$	ORC with RWC efficiency, $\eta_{RWC}$	Gain, $\delta\eta$
				[%]		
1	R123	2.331	1.143	10.63	10.64	0.09
2	R600a	3.387	1.256	10.57	10.72	1.42
3	SES 36	3.234	1.236	<b>10.87</b>	<b>11.58</b>	<b>6.53</b>

Other methods of increasing the efficiency, such as an overheated thermodynamic cycle, have also been taken into account in the study, but for the temperature range of interest, an increase in efficiency has not been achieved.

A different method of increasing the efficiency of a basic ORC cycle (with SES 36 working fluid) has also been examined – a concept to use a mixing heater powered at the outlet of the turbine. The results of this analysis showed an absolute increase of efficiency (in reference to a basic ORC) by  $\delta\eta_t = 0.39\%$  and a relative increase by  $\Delta\eta = 3.59\%$ , however, this increase is lower than in case of a heat regeneration exchanger utilization.

In general, one should notice that for the upper cycle temperature, utilizing a mixing heater does not provide higher efficiency in accordance to the exchanger. However, in a higher temperature range, one can expect that  $\eta_{PM} > \eta_{RWC}$ .

## Conclusions

Results of analysis of different work variants of an ORC system with different working fluids showed validity of using an SES 36 fluid working in a low temperature range, in comparison with other commercial working fluids.

The highest work efficiency was achieved in a cycle with a heat regeneration exchanger coupled within, however it is important to point out that if the temperature of the upper source is higher, introducing a mixing heater might be a better idea.

The properties of criteria numbers ( $Ja(T_1)$  and  $\Delta H(T_2)/h_{1,v}$ ) are used in a different method of evaluating the cycle's efficiency.

## Acknowledgement

This research work was supported by the European Union in the framework of the European Social Fund. The system project of the Pomerania province “InnoDoktorant – Scholarships for PhD students, II edition”.



HUMAN CAPITAL  
NATIONAL COHESION STRATEGY



POMERANIA  
VOIVODESHIP

EUROPEAN  
SOCIAL FUND



## References

- [1] Mikielwicz J.: *Odzysk ciepła odpadowego za pomocą obiegów freonowych*, Energetyka, Zesz. Nauk. Polit. Śląsk. 1989, (106).

- [2] Rubik M.: *Pompy ciepła – Poradnik*. Ośrodek Informacji „Technika instalacyjna w budownictwie”, Warszawa 2006.
- [3] Calm J.M. and Hourahan G.C.: *Refrigerant Data Summary*, Eng. Syst. 2001, **18**(11), 74–88.
- [4] Mikielewicz D. and Mikielewicz J.: *Mikrosiłownie – nowe zastosowania czynników chłodniczych*, Techn. Chłodn. Klimat. 2008, **3**(145), 98–105.
- [5] Hettiarachchi H.D.M., Golubovic M., Worek W.M. and Ikegami Y.: *Optimum design criteria for an Organic Rankine cycle using low-temperature geothermal heat sources*, Energy 2007, **32**, 1698–1706.
- [6] Mago P.J., Chamra L.M., Srinivasan K. and Somayaji C.: *An examination of regenerative organic Rankine cycles using dry fluids*, Appl. Thermal Eng. 2008, **28**, 998–1007.
- [7] Borjon A., Belledent J., Trouiller Y., Patterson K., Lucas K., Gardin C., Couderc C., Rody Y., Sundermann F., Urbani J.-C., Baron S., Foussadier F. and Schiavone P.: *Critical failure ORC: Improving model accuracy through enhanced model generation*, Microelectron. Eng. 2006, **83**, 1017–1022.
- [8] Yamamoto T., Furuhashi T., Arai N. and Mori K.: *Design and testing of the Organic Rankine Cycle*, Energy 2001, **26**, 239–251.
- [9] Wei D., Lu X., Lu Z. and Gu J.: *Dynamic modeling and simulation of an Organic Rankine Cycle (ORC) system for waste heat recovery*, Appl. Thermal Eng. 2008, **28**, 1216–1224.
- [10] Drescher U. and Bruggemann D.: *Fluid selection for the Organic Rankine Cycle (ORC) in biomass power and heat plants*, Appl. Thermal Eng. 2007, **27**, 223–228.
- [11] Liu B.-T., Chien K.-H. and Wang C.-C.: *Effect of working fluids on organic Rankine cycle for waste heat recovery*, Energy 2004, **29**, 1207–1217.
- [12] Mago P.J., Chamra L.M., Srinivasan K. and Somayaji C.: *An examination of regenerative organic Rankine cycles using dry fluids*, Appl. Thermal Eng. 2008, **28**, 998–1007.
- [13] Hung T.-C.: *Waste heat recovery of organic Rankine cycle using dry fluids*, Energy Conver. Manage. 2001, **42**, 539–553.
- [14] Maizza V. and Maizza A.: *Unconventional working fluids in organic Rankine-cycles for waste energy recovery systems*, Appl. Thermal Eng. 2001, **21**, 381–390.
- [15] Salehl B., Koglbauer G., Wendland M. and Fischer J.: *Working fluids for low-temperature organic Rankine cycles*, Energy 2007, **32**, 1210–1221.
- [16] Solkane 6.0.1.6 Software, Solvay Flour GmbH, 2008.
- [17] CoolPack 1.46 Software, DME TUD, 2001.

#### SYSTEMATYKA I KRYTERIA DOBORU CZYNNIKA ROBOCZEGO UKŁADU ORC DLA OKREŚLONYCH ZASOBÓW CIEPŁA ODPADOWEGO

Katedra Aparatury i Maszynoznawstwa Chemicznego  
Politechnika Gdańska

**Abstrakt:** Poprawa sprawności energetycznej procesów technologicznych stanowi obecnie – obok ograniczenia emisji gazów cieplarnianych i wykorzystania alternatywnych źródeł do produkcji energii – najważniejszy element idei zrównoważonego rozwoju. Niniejsza praca wychodzi naprzeciw rynkowym oczekiwaniom, wskazując możliwości wpisania się w ten trend. W procesach technologicznych ciepło odpadowe stanowi nie zawsze do końca rozwiązany problem. Zagospodarowanie tego ciepła, szczególnie w przemyśle rafineryjnym i petrochemicznym, napotyka na wiele trudności związanych z niską egzergią, znacznym rozproszaniem, dużym zróżnicowaniem parametrów i opłacalnością potencjalnej modernizacji. Jedną z obiecujących technologii utylizacji tego ciepła jest zastosowanie układu ORC. Niniejsza praca przedstawia globalne podejście do problemu uzyskania optymalnej sprawności układów ORC, z uwzględnieniem sprawności termodynamicznej. Przeprowadzono kompleksowy przegląd czynników termodynamicznych, możliwych do zastosowania w układzie ORC ze względu na zakres temperatury źródeł, bezpieczeństwo, cenę i ochronę środowiska. Stanowi ona zbiór ogólnych wytycznych przy wykorzystaniu literatury przedmiotu i doświadczenia badawczego zdobytego przy projektowaniu dla zakładów przemysłowych niekonwencjonalnych rozwiązań dotyczących zagospodarowania zasobów energii odpadowej. Jak się oczekuje, wykorzystanie instalacji do zagospodarowania energii odpadowej zapewni nie tylko poprawę wydajności procesów technologicznych, ale również poprawi proekologiczny wizerunek przedsiębiorstwa.

**Słowa kluczowe:** układ ORC, czynnik roboczy, zagospodarowanie ciepła odpadowego