



## FOUR-STROKE ENGINE WITH CENTRAL LOCATED, DIVIDED COMBUSTION CHAMBER

**Czesław Dymarski**

*Gdansk University of Technology*  
*Ul. Narutowicza 11/12, 80-952 Gdansk, Poland*  
*tel.: 48 058 3471608, fax: 48 58 3414712*  
*e-mail: cpdymars@pg.gda.pl*

**Gerard Rolka**

### **Abstract**

*The paper presents an original solution of the modern engine with the central located, divided combustion chamber. Such solution gives much better utilization of the warm what means that the efficiency of the engine should be higher and the fuel consumption and emission of the noxious gases such, as nitric oxides (NC), hydrocarbons (HC) and carbon dioxides (CO<sub>2</sub>), will be reduced. The engine can work on liquid or on gas fuels. Presently the prototype of this engine is being prepared for tests and some investigation works.*

**Keywords:** *engines, combustion chambers, emission of the noxious gases*

### **1. Introduction**

Currently the problems with environment protection and fuel economy are significant for engine producers. The new regulations limited permissible emissions levels of noxious gases from exhaust systems. It forced engine designers and producers to develop new and modernize existing solutions of engines.

In the paper the original solution of the modern engine is presented. It already has been patented in the Patents Office in the Germany [1]. This solution is designed for high- and middle-speed engines to use in driving systems of such vehicles as: lorries, locomotives and small vessels or to driving generators and various building machines. The engine can work on liquid fuels such as petrol, alcohol, or their mixture and on gas fuels for example: LPG, natural gas or biogas. There is also possibility to work on two different kinds of the fuels (for example: petrol and gas) simultaneously.

The engine can work on diesel oil or hydrogen also, but some modifications are necessary.

The principle of the working of the engine is similar to the common diesel engine. It means that the cylinders are always filled up with maximum quantity of the air and the parameters of the work of the engine are controlled by the quantity of the injection fuel.

The most important advantage of the presented engine is the use of the centrally located, divided combustion chamber. Such solution gives much better utilization of the air and warm in the comparison with typical engines applied at present. It means that the efficiency of the engine should be higher and the fuel consumption and emission of the noxious gases such, as nitric oxides (NC), hydrocarbons (HC) and carbon dioxides (CO<sub>2</sub>), will be reduced.

Presented in the paper drawings of the engine are simplified without details. Their aim is to show only the idea of the technical solution and the principle of the engine working.

## 2. Description of the engine construction

The axial section of the engine is shown on fig. 1. You can see there the main units and the elements of the engine, namely they are:

- Crankcase 1, inside which there are:
  - crankshaft, (not shown on the drawing),
  - articulated connecting-rod 2,
  - crosshead 3,
  - crosshead shoe 4,
  - sleeve packing 5,
  - piston rod 6.
- Cylinder 7, with the water jacket.
- Piston 8, inside which there are:
  - inlet valves 9,
  - pneumatic shock absorber 10,
  - bearing sleeve 11,
  - valve seat 12.
- Engine head 13, inside which there are:
  - four exhaust valves 14,
  - injection nozzle 15 of the combustion chamber,
  - injection nozzle 16 of the cylinder,
  - sparking plug 17.
- Cover 18 of the timing gear.
- Outlet pipes: left 19 and right 20.
- Inlet pipe 21.
- Circulating pipe 22 with the, located inside, control pipe 23.
- Inlet flap valve 24 with the spiral spring 25

The space inside the upper part cylinder, between the piston and the head create the main combustion chamber. The space inside the cylinder, between the piston and cover of the crankcase create the pre-compression chamber. At the upper position of the piston when its cylindrical protrusion is closing the small spherical chamber, there is created pre-combustion chamber. At the top dead centre (TDC) of the piston this chamber is practically closed.

The pneumatic shock absorber dampens the inertial forces at close by of the outermost position of the inlet valves.

## 3. Working principle

During the exhaust stroke (Fig.1) the piston rod 6 pushes up the piston 8, which pumps out combustion gas through the opened outlet valves 14 into the outlet pipes 19 and 20. Resistance of the flow of gas is very small because the use of four exhaust valves gives enough big their opening area.

At the moment when the flow of the air into the cylinder stops, the spring 25 closes the flap valve 24. Part of the lightly compressed air flows through the just opened inlet valves into the main combustion chamber, scavenging (blowing out) the rest of exhaust gas through the closing exhaust valves.

The piston is pulled down by the piston rod and beside of the opened inlet valves, the pressure of the air at the pre-compressed chamber a little increases and in the main combustion chamber decreases. It causes the pumping of the air through the valves in the piston and simultaneously a

small increase its temperature. Part of the air warmed by the hot surfaces of the head, the exhaust valves and the piston, mixes with the streams of the cool turbulent air, flowing into this chamber.

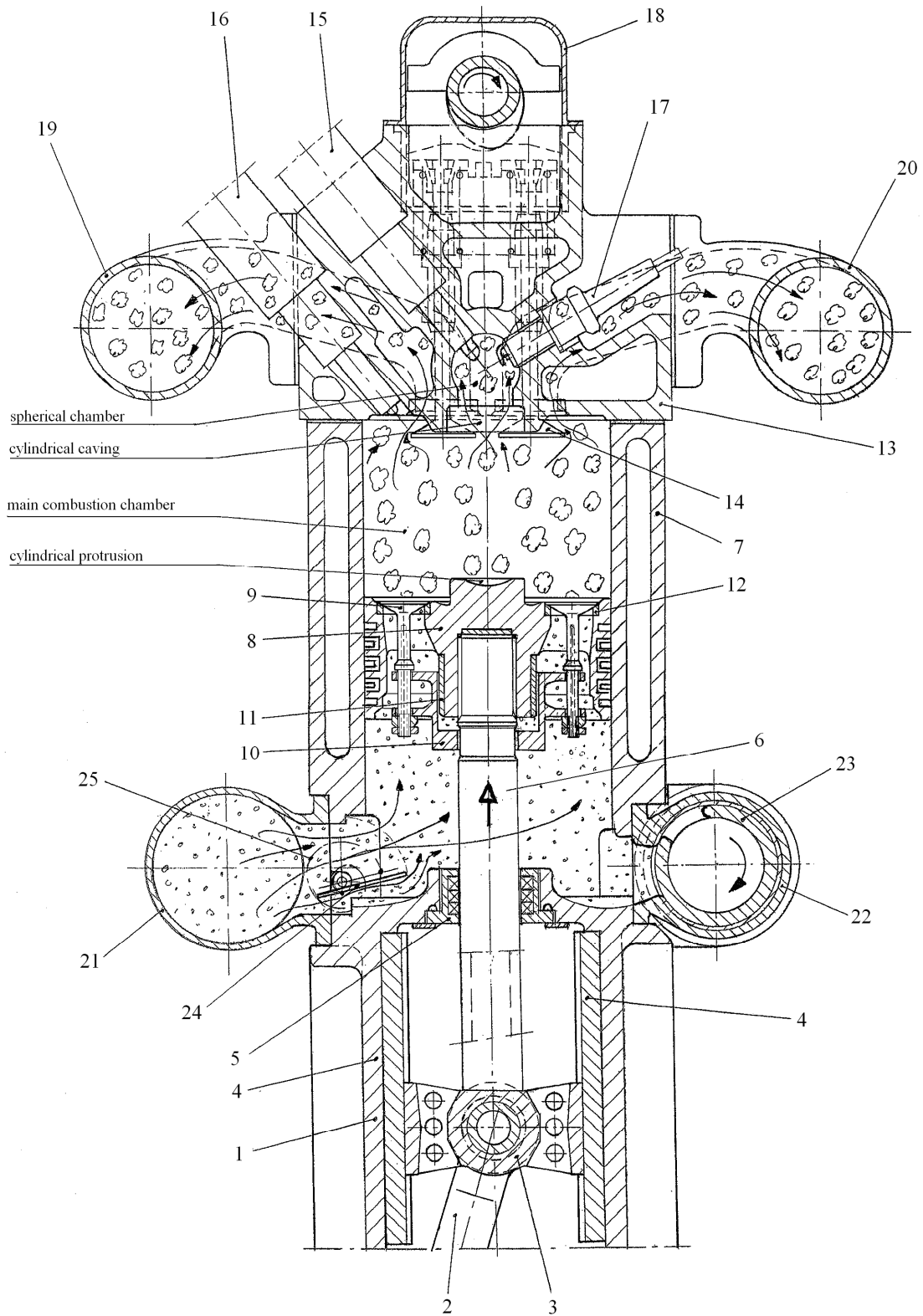

Fig.1. Axial section of the cylinder and the head of the engine

When the piston is approaching the inner dead center (IDC) its speed rapidly decreases and the inertial forces acting against the pressure forces start closing the inlet valves. Thanks to the shock

absorber the valves closes relatively smoothly just after the piston starts to move up. At this moment the compression stroke starts. The pressure and the temperature of the air quickly increase and the pressure forces keep the inlet valves in the closed position. The pressure decrease created in the lower part of the cylinder by the movement of the piston, causes an opening of the flap valve and a flow of the air from the inlet pipe into the cylinder. Resistance of this flow is very small because of the big opening area of the flap valve, what can be seen on fig.2.

#### 4. The control of the partially loaded engine

When the distance of the piston position to TDC (during the compression stroke) amounts about 25% of the stroke, some small quantity of the fuel is injected by the injectors 15 into the pre-combustion chamber. The injection causes turbulence of the air-fuel mixture with the minimum leakages outside this chamber.

Quantity of the injected fuel should be calculated with assumption that the excess air  $\lambda$  number of the air-fuel mixture in the pre-combustion chamber should amounts  $\lambda = 0.8 \div 1.2$  – for the petrol. After closing this chamber by the moving up piston there are very favourable condition for the intensive fuel evaporation and mixing with the air. The shape and geometrical parameters of the pre-combustion chamber are selected in such way that the increase of the pressure, the temperature and the compression ratio are bigger than in the main combustion chamber. Some losses of the pressure caused by a leakage of the mixture through the clearance into the main combustion chamber are very slight, thanks to the small value of this clearance, for example for diameter of the chamber  $D = 20 \div 30$  mm the radial clearance amounts  $C = 0.050 \div 0.15$  mm. The intensive flow of the mixture through this gap creates an aerodynamic lubrication layer and causes the local increase of the temperature.

Shortly after closing the pre-combustion chamber, what happens usually at the angle of the rotating crank shaft  $\alpha = 32 - 30^\circ$  before TDC, a sparking plug lights the air-fuel mixture and starts combustion process.

Just before TDC position of the piston the rotary valve 23, located inside the circulating pipe 22, starts to open the window. It enable, during a power stroke, the flow of the air from the pre-compression chamber, through the circulating pipe into another cylinder, where at this moment there is a intake stroke, what improves pressure charging effect.

When the piston reaches TDC and a power stroke starts, the spring 25 closes the flap valve 24 and as it was mentioned above, the air from pre-compression chamber is pumped out, by the moving down piston, into the circulating pipe.

At the same time inside the closed pre-combustion chamber burning process lasts. In spite of relatively high value of a compression ratio (amounts  $\varepsilon = 14$  – for petrol and  $\varepsilon = 14 \div 16$  – for gas) an explosive combustion does not take place.

The high pressure and temperature and sufficient quantity of the oxygen considerably limits a formation of hydrocarbons (HC) and emission of carbon monoxides (HC). On the contrary these conditions makes easier nitric oxides ( $\text{NO}_x$ ) formation, but there are not too much of them, because they form from small quantity of the air closed inside the chamber. The results of the numerical simulation of these process carried out at one of the German universities allows such interpretation.

At the beginning of the movement down of the piston, the burning gas rapidly flows through encircling gap into the main combustion chamber, where it mixes with the cooler air and causes sudden increase of the its temperature. Vapours of not completely combustioned fuel and other formed combustible gases (for example CO) after contact with the air continue burning. There occur some additional chemical reactions accompany a combustion process during which a quantity of emitted nitric oxides ( $\text{NO}_x$ ) decrease, as a result of the combustion gas cooling. The heating of the air by the combustion gas causes the quick increase of the air temperature and the

pressure. It improves a fuel utilization and increases the value and elasticity of the torque as well as the efficiency of the engine.

At short distance before IDC position of the piston the exhaust valves start to open and when the piston stops at IDC position the rotary valve closes and the one full cycle of the four-stroke engine is completed.

The control of the partially loaded engine is achieved by changing of a quantity of the injected fuel into pre-combustion chamber.

## **5. The control of the fully loaded engine**

For the fully loaded engine the power obtained from the even reach ( $\lambda = 0.8$  – for petrol) mixture burning inside the pre-combustion chamber is not sufficient to the demand. Because of it in the beginning of the intake stroke the injector 16 into the main combustion chamber injects the additional quantity of the fuel. This additional quantity of the fuel depends on the power demand.

The injected fuel warms, evaporates and mixes with the air. This mixture fills the upper part of the cylinder and the fresh, cooler air fills the lower part.

The compression stroke is similar to presented in chapter 4. Just before closing the pre-combustion chamber by the cylindrical protrusion of the piston, there starts fuel injection through the injector 15 and after ignition lag the burning process of the mixture takes place.

Meanwhile the pressure and temperature of the mixture inside the main combustion chamber are still rising but even at the TDC the temperature is enough lower than 1023 K, to protect from the self-ignition.

When the piston starts moving down, some losses of the combustion gases flowing into the main combustion chamber causes their mixing with the cooler mixture and its burning. This burning process proceeds smoothly and effectively with small emission of the toxic gases, similar as for the partially loaded engine.

For the maximum loaded engine the quantity of the fuel injected into the main combustion chamber should be calculated for obtain there the excess air number equal  $\lambda = 1.0 \div 1.1$ . For the engine load only a little bigger than it could be obtained from the pre-combustion chamber only, the quantity of the fuel injected into the cylinder should be suitable for receiving  $\lambda = 5$  and even more. Meanwhile the quantity of the fuel injected into pre-combustion chamber must be calculated to obtain there the excess air number  $\lambda = 1.1 \div 1.2$  – including a part of the mixture created in the cylinder during the compression stroke and closed inside this chamber.

## **6. The piston lubrication system**

At the presented solution of the engine there was applied the pressure-circulation lubrication which is shown on fig. 2. The oil is pumped through the holes in the crankshaft, connecting rod, crosshead, piston rod and piston into the circumferential groove. The piston is equipped with two oil scraped rings: one above and second below the groove with the oil. The used oil is scraped from the internal surface of the cylinder and flows out through the holes in the piston, piston rod, crosshead, connection rod and crankshaft into the suction inlet of the cleaning circulation pump. The oil groove and the both grooves with the scraped rings are connected by at least three radial holes each with the mentioned above oil supply and drain holes.

## **7. The sealing of the inlet valve**

The inlet valves are joined to the elastic elements of the pneumatic shock absorber, which can move axially on the piston, and is turn protected in relation to it. The valve stems are made with the axial holes for mass reduction..

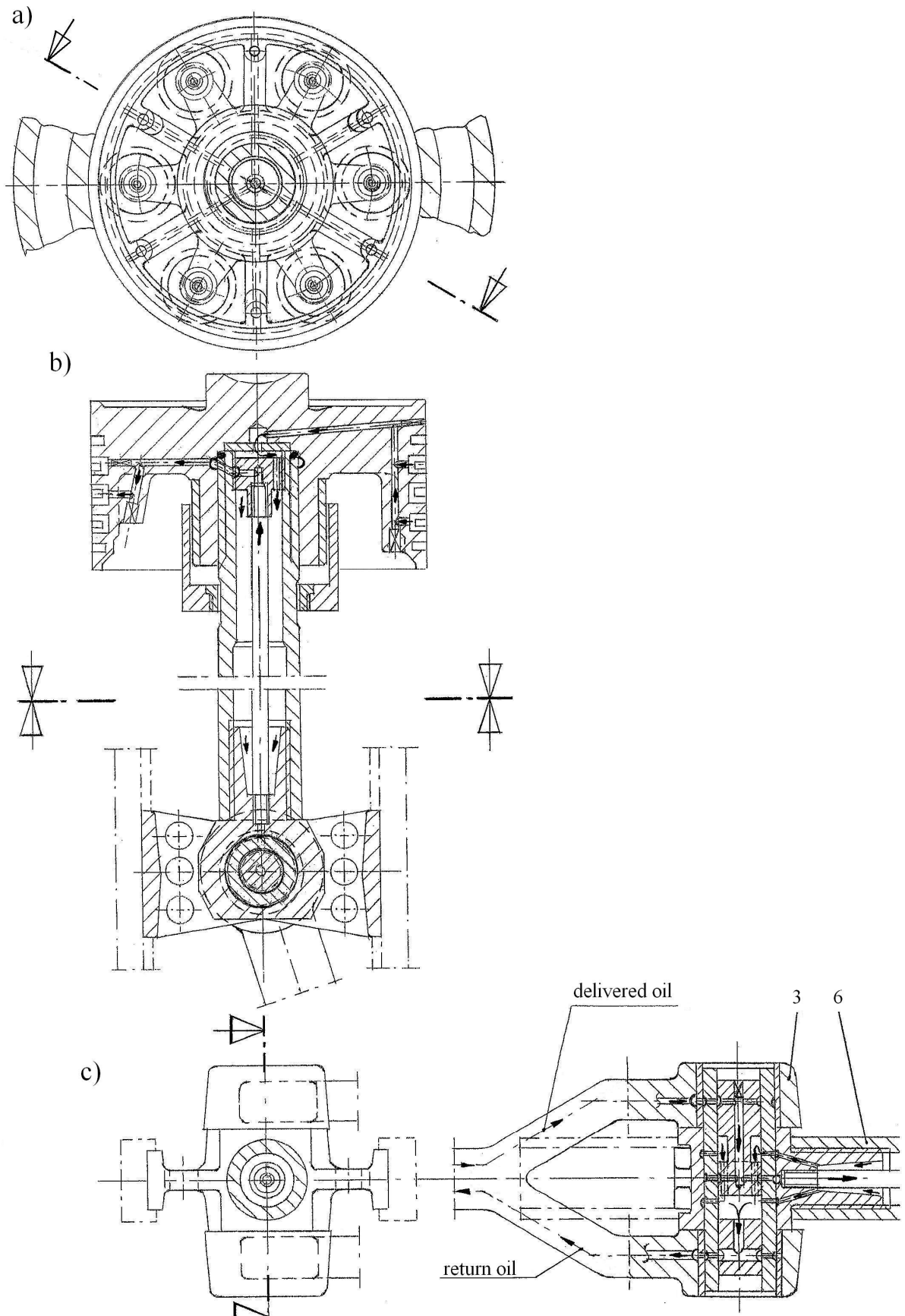

Fig. 2. The piston lubrication system: a) cross-section of the cylinder and the piston; b) axial section of the piston, the piston rod and the crosshead; c) axial section of the crosshead and the articulated connecting-rod

The stem of each valve is set in the shock absorber with same clearance. The contact spherical surface of the valve-head is made with a little smaller radius than the surface of the valve-seat. It enables better matching the valve head to the valve seat and good leak tightness.

## **8. Final remarks**

Construction solution of the engine presented in the paper contains same original fishes and is patented [1]. Mentioned above advantages of the engine, especially such as high efficiency and low emission of the toxic gasses should be proved. It needs some research works at the laboratory stand. Presently the prototype of this engine is being manufactured in one of the Gdansk workshops.

It is quite possible that in the next year we shall be able to publish the first results of this investigation works and better assess advantages and disadvantages of the presented engine.

## **References**

- [1] Rolka G., *Verbrennungs-4-Takt-Kolbenmotor mit axialstromigem zyklischem Gaswechsel im Zylinder und zentral liegender geteilter Brennkammer*. Bundesrepublik Deutschland. Urkunde über die Erteilung des Patents Nr. 10 2004 013 461. Submitted 18.03.2004. Published 01.03.2007.
- [2] *Kraftfahr technisches Handbuch*, 22.Aufl., 2004.
- [3] Wajand Jan A., *Tłokowe silniki spalinowe średnio- i szybkoobrotowe*. Wydawnictwa Komunikacji i Łączności WKŁ, 2000 r.