

NEW TOOLS IN PROJECT SCHEDULING. CHALLENGES OF THE CONSTRUCTION PROJECT PLANNING

Orsolya BOKOR*, **Tamás KOCSIS**, **Gabriella SZENIK**

Szent István University, Ybl Miklós Faculty of Architecture and Civil Engineering, Department of Construction Management,
Budapest, Thököly út 74., H-1145

Abstracts: The traditional (e.g. Gantt chart) and modern (network modeling) scheduling techniques reach their limits quite soon in case of large projects. In case of thousands of activities, the current methods do not provide an effective evaluation. This paper would like to show tools that can solve the above-mentioned problem. We have several options for handling these matters effectively. For example: fine scheduling based on resource and cost use, innovative solutions for printing of complex schedules. The latter includes the poster-like presentation of several plan details. These applications can be considered novelties in project planning methodology.

Keywords: construction technology models, network planning, project planning, resource planning.

1. Historical overview

The word 'project' originates from the Latin word 'projectum', which comes from another Latin word 'proicere' meaning 'to throw forward' (Merriam-Webster). The term originally meant 'something that comes before anything else happens'. According to the Merriam-Webster Dictionary, its first known use can be dated back to the 15th century. However, we would like to start this overview at the very end of the 19th century instead.

1.1. Traditional Planning Techniques

The era of traditional planning techniques started in 1916 when Henry Gantt's 'Work, Wages, and Profits' was published. However, Gantt published an article as early as 1903, where his brand-new method of visual display appeared.

1.1.1. Gantt Chart

Karol Adamiecki developed a new type of diagram, which can be seen in Figure 1, in 1896. Even though he called it the harmonogram, we know it today as the Gantt chart. This contradiction could occur due to the fact that Adamiecki had not published his diagram until 1931, and even then only in Polish.

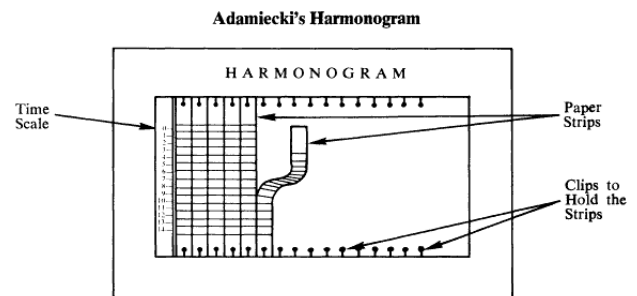

Fig. 1. Harmonogram (source: <http://en.wikipedia.org>).

The Gantt chart is basically a bar graph: time is represented on the horizontal axis and the activities are on the vertical one. Bars are drawn between the starts and finishes of the tasks. As an improvement, in order to be able to display the level of completion as well, another bar appeared in the strip of the activity. This line began at the actual start and ended at the date belonging to the percent of completion. See Figure 2 for an example.

Of course, this method has its disadvantages as well, but it cannot be denied that this is the most widespread way of displaying project plans. Another proof of its marvelousness is the fact that, even after almost a hundred years, it is applied in every project planning program. Naturally, the Gantt chart has been constantly developed, which will be discussed later.

* Autor odpowiedzialny za korespondencję. E-mail: bokor.orsolya@ybl.szie.hu

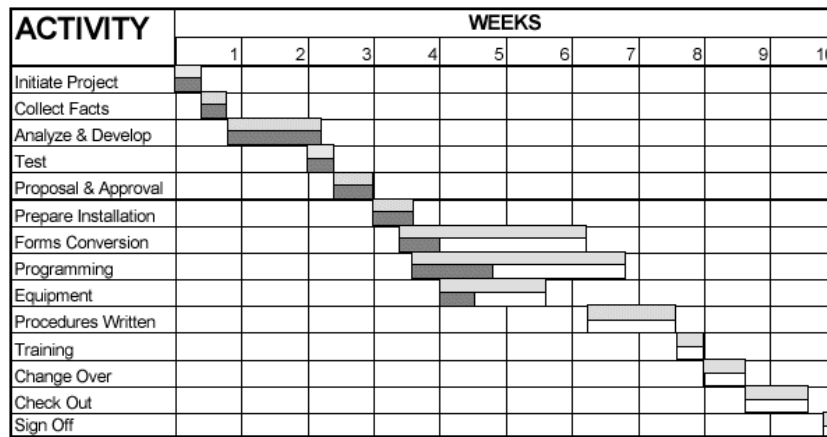

Fig. 2. Example of a Gantt Chart (Source: Implementing change, Dr. Ben S. Graham Jr., http://www.worksimp.com/articles/implementing_change.htm).

1.1.2. Cyclogram

One of the downsides of using a Gantt chart is that it does not indicate the technological problems, spatial troubles. The intensity of the activity and the performance determined by the resources do not show on a Gantt chart. In order to avoid the above-mentioned situation, construction industry uses the cyclogram.

On the vertical axis the percent of completion is represented as the function of time. As a result, the technological problems will be obvious. For instance, Figure 3 shows a pipeline construction example. At one section the laying of the pipes precedes the excavation, which is impossible, of course. In case of infrastructural constructions, line-like projects, eg. highway, railway, sewage system etc. construction, a cyclogram is a useful way of displaying the project plan. In such instances, the cross-sections are represented on the vertical axis. This method can be applied when the spatial planning of especially risky projects is key. For example, in case of The M0 Northern Danube Bridge Construction, Hungary project (<http://www.eszaki-hid.hu>), a cyclogram was made for the construction of the two pylons.

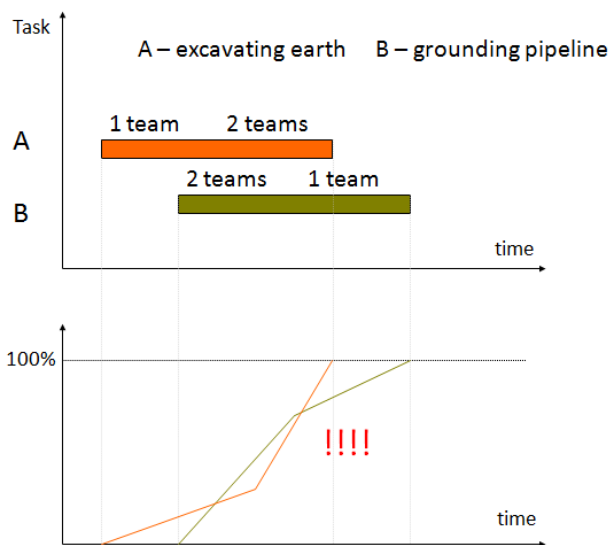

Fig. 3. Example of a cyclogram (source: own educational material).

1.2. Network planning techniques

Network planning and together with that modern project management was born in 1959 when the CPM network was created by Kelley and Walter (1959). The network is a graph with directed edges. The activity durations are given in a deterministic way. The longest path, the critical path, gives the project duration. PERT (Program (or Project) Evaluation and Review Technique) is similar but here the task durations are determined in a stochastic way.

Figure 4 shows an example for the CPM network. The vertices are illustrated by circles, these are the events and the arrows stand for the directed edges, which are the activities. The events are certain dates that mark the finish of the tasks that are directed towards them and the start of other activities that come out of them. The numbers in the nodes show the early and late occurrence of the events. The red line demonstrates the critical path. In this example, the project duration is 17 days. This technique is capable of storing the logic that has created it; the connections between the tasks are shown. Consequently, the possible modifications can be dealt with more conveniently. If, for example, one activity duration is changed, there is no need for making a whole new plan, only the network has to be recalculated.

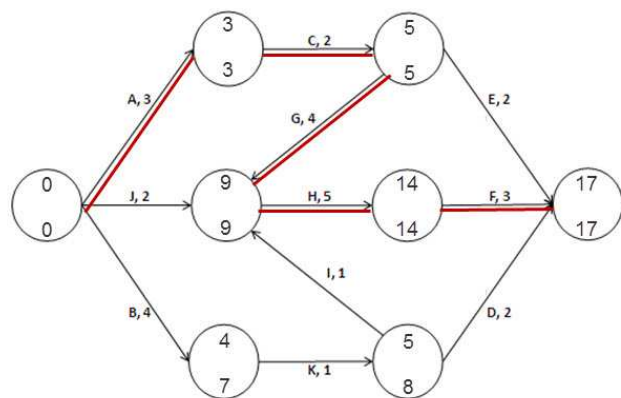

Fig. 4. Example for a CPM Network (source: own educational material).

Of course, this method has its disadvantages as well. For instance, only simple dependencies can be handled. Usually the tasks are carried out parallel to each other, which requires the definition of more complex relationships. For the management of this a new network technique was needed. It is the so-called Precedence Diagramming Method (PDM), which is frequently referred to in Europe as MPM (Metra Potentials Method). In connection with this technique two names have to be mentioned: Roy (1959) and Craig (1964).

This method allows the definition of more than one and more complex logical dependencies between activities.

Figure 5 shows an example for the PDM network.

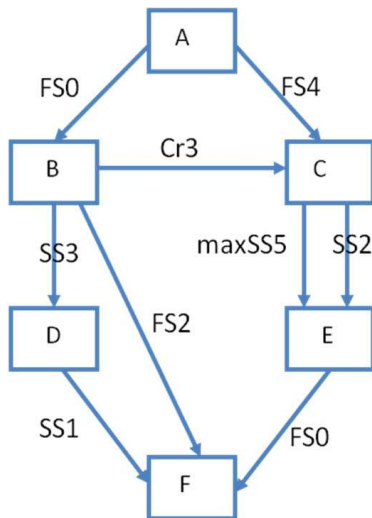

Fig. 5. Example for PDM Network (source: own educational material).

As opposed to the CPM network, in this directed graph the vertices represent the tasks and the edges the relationships between them. A very important criterion is that the activities have to be carried out with the same intensity and without interruptions as shown in Figure 6.

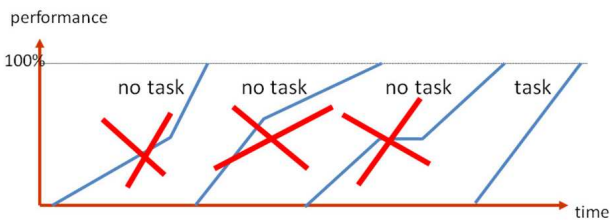

Fig. 6. Definition of Activities in a PDM Network (source: own educational material).

All tasks have two distinguished points: the start and the finish, which are somehow connected to other activities' distinguished points. The successor is a task whose distinguished point depends on another task's, the predecessor's, distinguished point (Hajdu, 1996b).

The following minimal-type relationships are allowed to be defined in a PDM network:

- SSz At least z amount of time should pass between the start of the predecessor and the start of the successor;

- FSz At least z amount of time should pass between the finish of the predecessor and the start of the successor;
- FFz At least z amount of time should pass between the finish of the predecessor and the finish of the successor;
- SFz At least z amount of time should pass between the start of the predecessor and the finish of the successor.

The following maximal-type relationships are allowed to be defined in a PDM network:

- maxSSz Maximum z amount of time could pass between the start of the predecessor and the start of the successor;
- maxFSz Maximum z amount of time could pass between the finish of the predecessor and the start of the successor;
- maxFFz Maximum z amount of time could pass between the finish of the predecessor and the finish of the successor;
- maxSFz Maximum z amount of time could pass between the start of the predecessor and the finish of the successor.

Any combination of the above-mentioned logical dependencies is allowed to be defined between any two tasks. The most common combination is the pairing of the SSz relationship with FFz. Therefore, they can be merged into one single relationship (Figure 7), the so-called critical relationship. (Hajdu and Klafszky, 2002)

- ·Crz There should be at least z amount of time between the predecessor and successor activities in every cross-section;
- ·maxCrz There could be maximum z amount of time between the predecessor and successor activities in every cross-section.

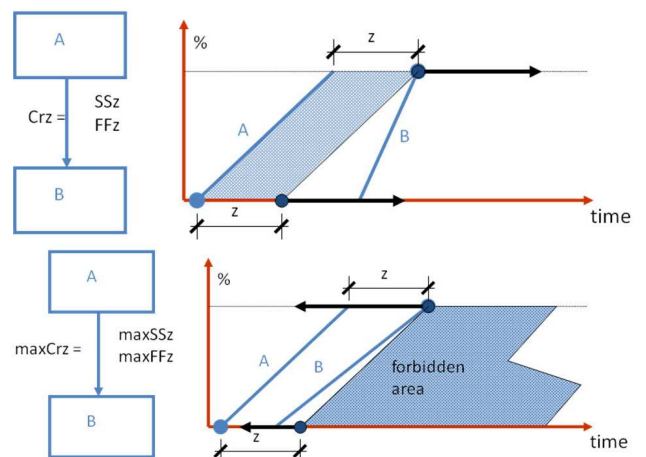

Fig. 7. Minimal and Maximal-type Critical Relationships (source: own educational material).

In order to summarize the theoretical knowledge described so far and to show the practical application of the PDM network, here is a very simple example from the construction industry.

Example: Shoring (B) can start after the excavation (A). The shoring material is transported here from another trench section, after its backfill. The trench cannot stay unshored for more than a day. Figure 8 shows the correct logical dependencies in both a PDM network and a Gantt chart.

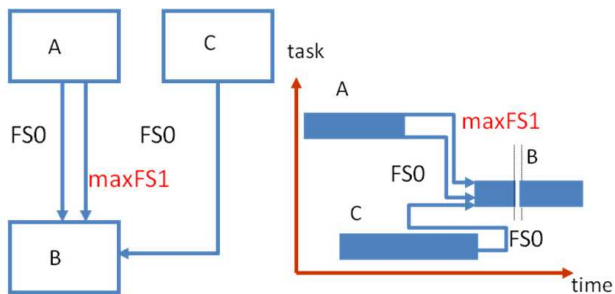

Fig. 8. Practical Application of PDM Technique (source: own educational material).

The historical overview of the network planning helps us understand why project planning in the construction industry is a special field and why these new, innovative solutions and project planning tools are very much needed.

2. Project Planning in the Construction Industry

Project planning varies from one industrial branch to another. The expectations are entirely different in case of IT, bank or construction industry projects. Even within one branch there could be many types of demands, aims and realization. Totally different approaches are anticipated in case of an office building, highway or metro construction. Naturally, the general characteristics of project management are present everywhere. In addition, the special features of the industry branches render the making of correct plans difficult (PMI, 2006; Hajdu, 1996a).

2.1. Characteristics of the construction industry

The specific features of the construction industry fundamentally determine the main directions of project planning. The most important characteristics are the following:

- Site of works are spread out: every project is carried out at a different location. Consequently, the given environment affects the realization.
- Great volume: the volume of the projects is large compared to the size of the companies. It is possible that only one or two projects give 90-95% of the annual income of the firm. This could be a huge burden because even smaller mistakes, which are mostly irreversible processes, can result in enormous costs.
- Uncertainties: variations of any kind – for example a change in the client's demands, scope or in the applied technologies or materials – can occur in any phase of the project. As a result, the costs are

constantly changing as well. Generally the contract has to be modified as a consequence too.

- Uncertainties in design: usually, bids have to be made based on incomplete plans, and the lack of information makes the precise planning of costs and returns impossible.
- Many stakeholders: communication between the stakeholders is of great importance. The main problem is that the stakeholders can change or appear in different roles. Communication requires considerable resources and time.

2.2. Problems with Modeling the Special Characteristics

In the following sections, some important problematic areas are discussed, which construction industry expects of today's modern project planning to solve.

2.2.1. Modeling Technological Problems

The applied technology is a key factor in the phase of construction. Consequently, the planning and modeling of it are of great importance. The following two examples attempt to shed a light on the significance of taking the applied technology into account at the stage of planning as well.

- a) Two activities have to be performed by the same expensive machine. Due to the fact that the machine is rented, the time spent on site should be minimized and there should not be a break between the two activities. What are the correct task dependencies?

The solution can be seen in Figure 9. When modeling the situation, minimal-type relationships will not suffice. Version P0 seems correct but if the activity duration of C increases (version P1), there is going to be one day when the machine is paid for no work at all. By defining a maximal-type relationship between A and B (P2), the one-day break can be avoided and an adequate modeling of the situation can be created.

- b) A long trench should be excavated. The breaking of the pavement is performed by a hydraulic excavator with a breaking attachment, while the excavation is performed by the same type of excavator with a trenching bucket attachment. There should be a two-day safety distance between the two excavators. What kind of task dependency should be defined between the two activities?

The solution can be seen in Figure 10. The correct relationship is Cr2, in other words the combination of a Start-to-Start and Finish-to-Finish dependencies. Applying only one of the two can result in technological problems. For example, if we only define SS2, then the excavation may finish before the breaking of the pavement. In this case, the logical relationships should be revised every time the activity duration changes. If the critical relationship is used, the result will always be technologically correct. Applying a Finish-to-Start relationship may bring about longer project duration.

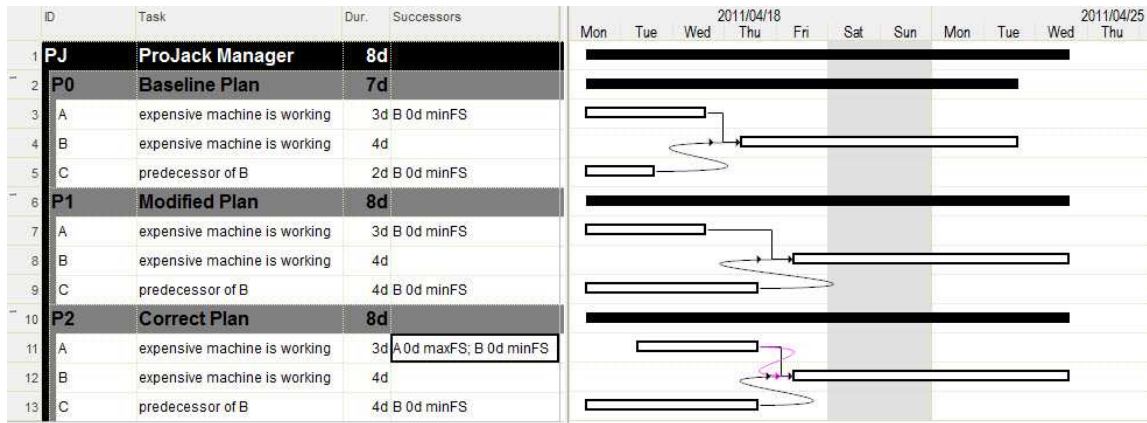

Fig. 9. Problem 2.2.1/a.

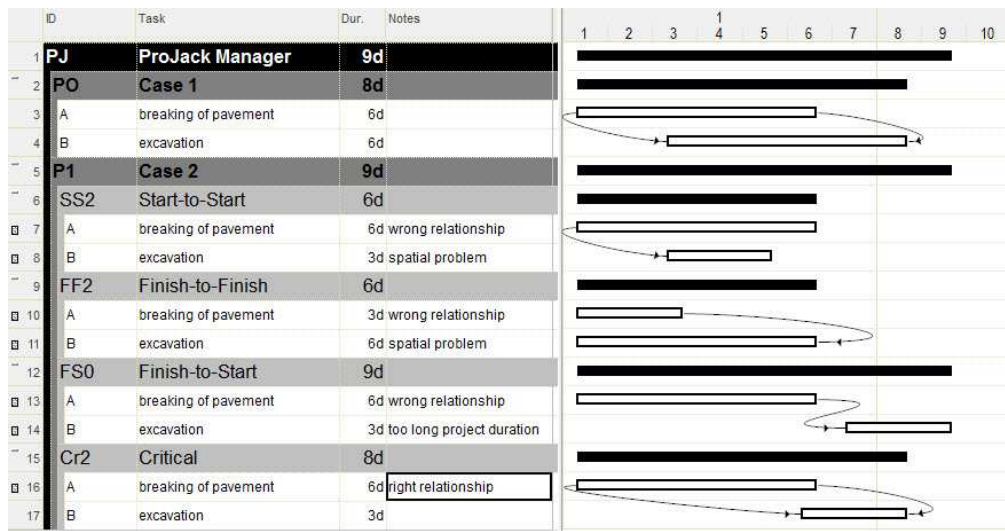

Fig. 10. Problem 2.2.1/b.

2.2.2. The Effects of Resource Allocation on Costs

How the resources are utilized is especially important in case of all kinds of projects. Consequently, special attention has to be paid to the effective use of resources concerning construction industry projects as well. In order to facilitate finding the ideal solutions, all project planning programs should handle assigning resources to tasks and resource planning. Every application manages resources

in a different way; we would like to concentrate on just one example.

The utilization of the two excavators (mentioned in problem 2.2.1/b) can be seen in Figure 11. There are only three machines of each kind. The color green shows this limit, red marks where more machines would be needed than the maximum. According to this plan, six excavators would be needed instead of three. At the bottom of the figure those activities are listed to which excavator 1 is assigned.



Fig. 11. Resource Plan before Fine Scheduling.

It is an important feature of every project planning tool how flexibly it can handle the mathematical models of the network plans when it comes to practical applications. For instance, defining primary and scheduling constraints can be allowed in order for the user to be able to perform fine scheduling. Figure 12 shows the result of fine scheduling. In this case, logical relationships were defined in order to avoid the overloading of resources. Another option would have been to use the built-in resource planning application of the software. With the help of resource allocating algorithms in the program, time or resource constrained planning can both be performed (Görög, 2003).

2.2.3. Connection between the Budget and the Schedule

Cost plans of construction industry projects are usually more complex than those of other type of projects. Generally the breakdown of costs differs from the breakdown of activities. Budget items show us probable

expenses and returns but these should be somehow connected to the activities of the schedule. There could be different kinds of combinations. Figure 13 shows the possible approaches.

Modell (A) illustrates the scheduling based on resources, where the costs of the activities are calculated from the cost of the assigned resources. Modell (B) demonstrates the connection between the schedule and the budget, where the budget items, and costs and returns together with them, are assigned to the tasks. This could be typically done by a general contractor, then the items contain the costs of the subcontractors. Modell (C) is a complex solution: returns can be calculated on the side of the tasks, while their costs come from the costs of the resources assigned to the items. High-standard project planning requires the application of such models or even the combinations of them. This renders the effective use of Earned Value Management (EVM) in project control viable.

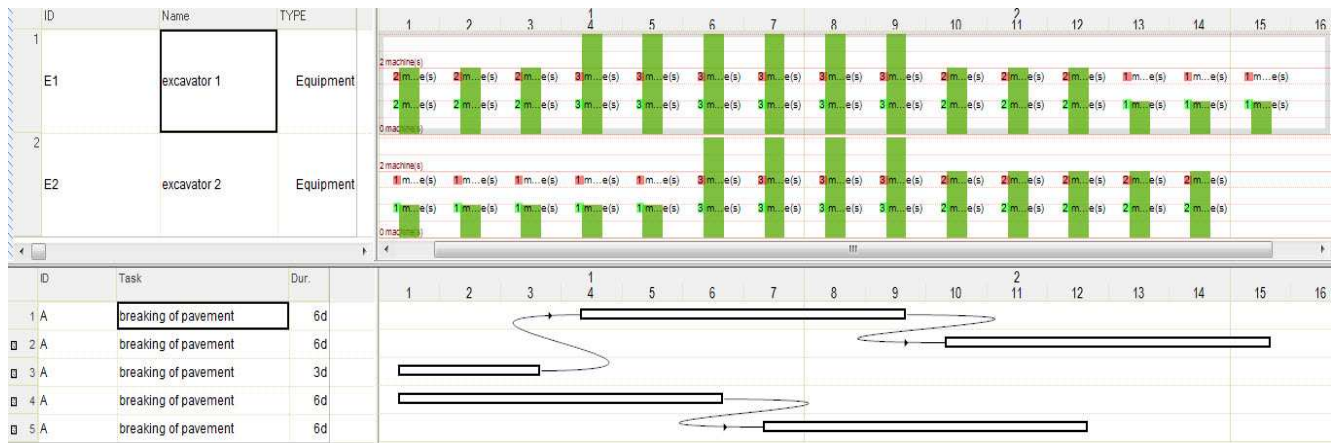

Fig. 12. Resource Plan after Fine Scheduling.

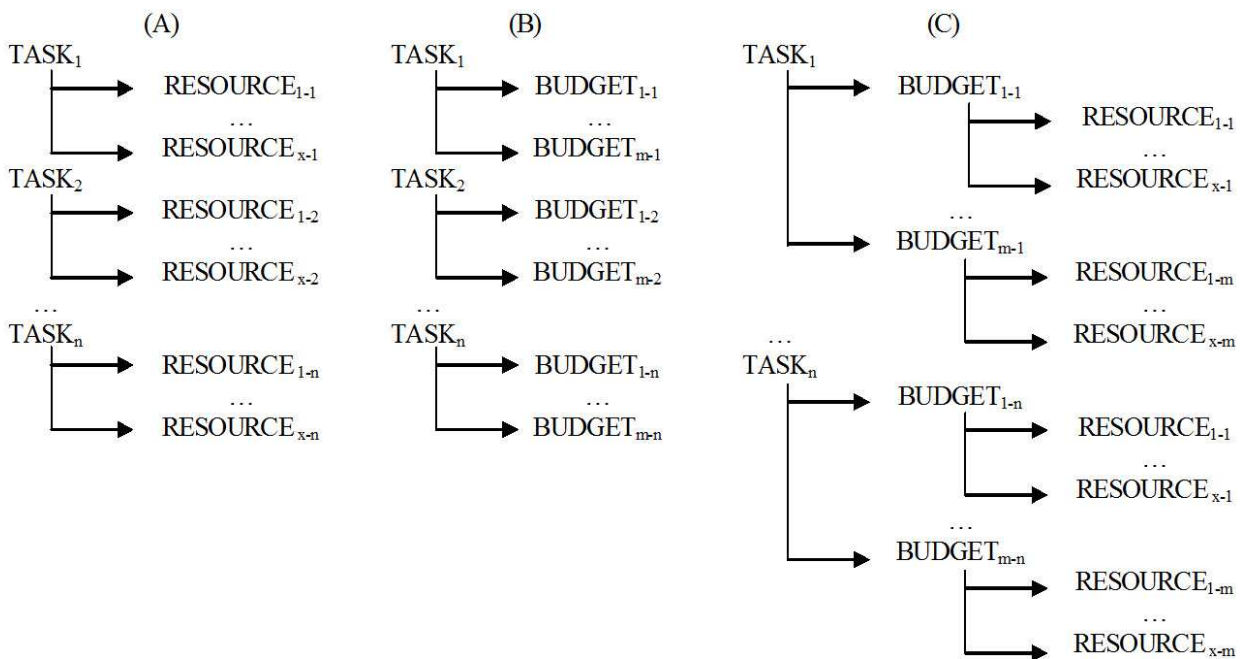

Fig. 13. Types of Construction Industry Schedules Based on Assignment.

2.2.4. Visualization

The visual display of project plans is a key factor in gaining information about them very quickly. In the following examples, some demands concerning the appearance of the plans are listed.

- 1) In case of railway construction projects, not only the cyclogram is able to display the plan in the most ideal way, the timescale units of the Gantt chart can be set differently as well. There could be certain tasks in the beginning of the project that are many months long or at the end that are weeks long. However, there could be a short period where the unit should be day or minute even, for example, in case of shutdowns. It is a great challenge for the current programs to create a schedule that can be printed well. This kind of plan can be fitted to an A0 sized paper, but without the scale segmentation it could be three or four pages. Moreover, usually there is a lot of empty space on a schedule, where we can place other important information, thus creating poster-like representations. The following example is too large to be put in this article but it can be accessed via the link given below: <http://www.projackmanager.com/sites/www.projackmanager.com/files/projack2010.pdf>
- 2) Another requirement could be that the representation of task should provide extra information other than the start and the finish of the given activity. The last few years saw great development in this topic, including big software companies. For instance, the critical and non-critical or the finished and in-progress tasks can be displayed in different ways. The state according to the baseline plan can also be shown. In case of high-standard plans, it should be indicated, if to the given task another calendar is assigned that is different from the basic calendar. For example, if work is performed even in the night shift, then that activity should be distinguished from the others.
- 3) Furthermore, it is also expected that not only time-type data should be displayed but cost-type data as well. This way it can be shown how the costs and returns change over time and by tasks (Figure 14) and budget items.

3. Conclusion

In summary, it could be concluded that in case of construction industry projects numerous functions and

solutions are required in order to create a detailed project plan that are not necessary in case of general project planning. Examining the features of the existing project planning applications, it cannot be stated that any one of them is more suited to the planning of construction projects than the others. (<http://www.projackmanager.com>, <http://www.microsoft.com/project>, <http://www.oracle.com>, <http://openproj.org>).

However, it can be expounded that there is a connection between the detailedness and complexity of the project plan and the flexible application of the network planning techniques' system of conditions. If the goal is a project plan that does not require detailed technological models, special tasks and resources, then the general project management programs are sufficient. If special features of the construction industry have to be modeled, it is worth using programs tailored for the planning of construction projects. In case of larger projects, the project duration and the size of the project allow us to create plans that are detailed enough to adequately model the technology as well. Experience proves that the energy invested in detailed project planning and control recoups during the realization of the project.

References

- Hajdu M. (1996a). Network Scheduling Techniques for Construction Project Management. *Kluwer Academic Publisher*. ISBN 0-7923-4309-3.
- Hajdu M. (1996b). PDM Time Cost Trade Off: Activities Are Splittable or Non-Splittable. *Optimization*, Vol. 38, 155-171.
- Kelley J.E., Walker M.R. (1959). Critical Path Planning and Scheduling, In: *Proc. the Eastern Joint Computer Conference*, Boston.
- Roy B. (1959). Theorie des graphes: Contribution de la theorie desígraphes a l'etudede certains problemes linearies. *Comptes rendus des Seances de l'Academie des Sciences, seence du Avril 1959*, 2437-2449.
- Craig J. (1964). IBM Users Manual for IBM 1440 Project Control System.
- Görög M. (2003). A projekttervezés mestersége. *AULA*, Budapest,
- Hajdu M., Klafszky E. (2002). Hálós tervezési technikák az építések tervezésében és irányításában. *Műegyetemi Kiadó*, Budapest.
- PMI (2006). Projektmenedzsment útmutató - PMBOK Guide. *Akadémiai Kiadó*, Budapest.