

## FRACTURE TOUGHNESS OF 19Mn5 STEEL PIPE WELDED JOINTS MATERIALS

Mykolas DAUNYS\*, Povilas KRASAUSKAS\*, Romualdas DUNDULIS\*

Machine Design Department, Kaunas University of Technology, Kęstučio 27, LT-44021 Kaunas, Lithuania

[Mykolas.Daunys@ktu.lt](mailto:Mykolas.Daunys@ktu.lt), [Povilas.Krasauskas@ktu.lt](mailto:Povilas.Krasauskas@ktu.lt), [Romualdas.Dundulis@ktu.lt](mailto:Romualdas.Dundulis@ktu.lt)

**Abstract:** This paper presents an investigation of Ignalina NPP reactor's main circulated circuit (MCC) pipeline welded joints materials fracture toughness properties. Standard compact C(T)-1T specimens containing "V" and "K" – type welds were cut off from the various MCC pipe's zones, produced from the 19Mn5 steel pipe and welded by electrodes UTP-068HH, YONI-13/55 and CT-36. Critical  $J$  – integral  $J_{Ic}$  values were defined using  $J$ – $R$  curve test method, which results on determination of  $J$  – integral values as a function of crack extension  $\Delta a$ . The investigation enables to calculate critical crack length  $\Delta a_{max}$  and  $\Delta a_c$  sizes and  $J$  – integral  $J_{Ic}$ ,  $J_{max}$  and  $J_{Pmax}$  values, which are used to predict safe service lifetime of the cracked pipelines.

### 1. INTRODUCTION

The elements of the nuclear power plant (NPP) pipelines, also heavy loaded parts of other NPP structures (e.g. turbine rotors, its blades), during turbine start up, power download, testing or overloads during emergency situations, stresses and strains reaches its dangerous values, in some cases exceed limited ones.

The overloads in stress concentration zones, cracked parts or welded joints calls stress concentration, which cause crack origination and fatigue its growth and are one of the reasons of structure fracture. In order to examine lifetime of the repaired pipes welded zones it is necessary to know static and cyclic characteristics of the materials.

The inspection of the pipelines during exploitation by using nondestructive control methods has showed presence of crack type damages in the welded joints and its surrounding zones. According to the requirements of reactor technological regulation, cracks in the welded joints of the reactor's main circulated circuit are unallowable, so in the case of one's detection, it should be repaired until crack sizes reach dangerous values.

In order to evaluate the forecast of such situation, it is necessary to dispose of material fracture toughness characteristics, which are used for evaluating pipe material resistance to the crack propagation.

The pipelines of the main circulated circuit were produced from the low carbon steel 19Mn5 with diameter of  $\varnothing 630$  mm and wall thickness of 27mm and welded using pearlite structured electrodes YONI-13/45 and YONI-13/55 or high Ni concentration alloyed electrodes UTP-068HH and CT-36, thus the goal of our investigation was focused on definition of the fracture toughness criterion  $J$  – integral  $J_{Ic}$  for these MCC pipeline welded joints.

### 2. SPECIMENS AND TESTING TECHNIQUE

Chemical composition of tested materials is presented in Table 1, mechanical characteristics – in Table 2.

Investigation of fracture toughness criterion  $J$  – integral has been carried out on the standard compact C(T)-1T specimens (Fig. 1) cut off from the pipe's welded zones with various welds configuration.

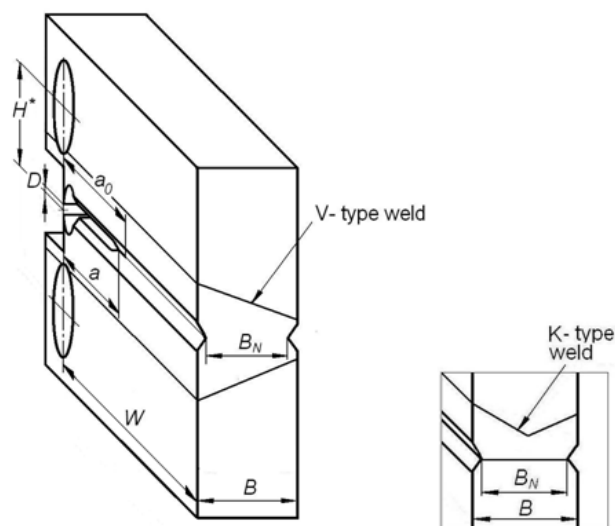

Fig. 1. Shape and dimensions of compact specimen with "V" and "K" - type welds

In four specimens with "V" – type weld were cut off from 19Mn5 steel pipe welded by electrodes CT-36 and YONI-13/55, two specimens containing "V"– type weld and three specimens containing "K" – type weld we cut off from the pipe's joint produced from 19Mn5 steel pipe welded by electrodes UTP-068HH (Tab. 3). The last

ones were used to evaluate heat affected zone influence on crack resistance and fracture  $J$  – integral value.

In total, 13 specimens were tested to evaluate fracture characteristics of the MCC pipeline welded joints. Such selection of the weld types allowed evaluation fracture properties in the welds metal and in the joint heat affected zone as well.

Testing of the specimens has been performed at ambient temperature on the 50 kN capacity low cycle tension-compression testing machine according to the requirements presented in the standard ASTM E1820–08 (ASTM E1820-08). Testing machine drive during specimen reloading was controlled by high speed X-Y recorder.

According to the requirements (ASTM E1820-08), the specimens were precracked on a high frequency hydraulic testing machine keeping the ratio  $a/W$  (crack length vs width of the specimen) in the limits of  $0.48 \leq a/W \leq 0.73$  (Tab. 3).

When the sharp fatigue cracks were done, in order to maintain brittle crack growth, in the forecast crack propagation plane, on both sides of the specimen were made grooves in depth of 2 mm (Fig. 1).

Measurements of the specimens and precracking data are presented in Table 3.

**Tab. 1.** Chemical composition of 19Mn5 steel pipe and weld metals

Material	Amount of elements in %								
	C	Si	Mn	S	P	Cr	Ni	Mo	Addition
19Mn5	0.220	0.39	1.23	0.003	0.007	0.30	0.22	-	Cu 0.067
UTP-068HH	0.023	0.37	4.70	0.006	0.009	18.8	70.45	0.67	Fe 2.93; Cu 0.01; Ti 0.07; Co 0.01; Al 0.01; Nb 1.95
YONI-13/55	0.093	0.39	0.85	0.090	0.030	-	-	-	-
CT-36	0.051	0.10	7.96	0.005	0.005	-	61.2	6.16	Ti<0.1

**Tab. 2.** Mechanical characteristics of 19Mn5 steel pipe and weld metals

Material	Yield strength $R_{p0.2}$ , MPa	Ultimate strength $R_m$ , MPa	Reduction of cross-section area $Z$ , %	Elongation $A$ , %	Young's modulus $E \times 10^5$ , MPa	Energy density $a_H$ , J/cm <sup>2</sup>
19Mn5 steel pipe	490	600	78.5	-	1.9	-
Weld metal UTP-068HH	408	685	40.7	44.0	-	-
Weld metal YONI-13/55	364	577	-	28.3	-	24.9
Weld metal CT-36	311	595	-	28.2	-	18.7

**Tab. 3.** Measurements and precracking data of the specimens

Specimen N <sup>o</sup>	$W$ , mm	$B$ , mm	$B_N$ , mm	$a_0$ , mm	$a_0/W$
Weld metal CT-36 "V"- type weld					
1	24.75	20.75	50.00	27.65	0.553
2	24.35	20.35	50.35	30.82	0.6121
3	24.35	20.35	50.35	27.44	0.545
4	24.85	20.85	50.10	25.69	0.513
Weld metal YONI-13/55 "V"- type weld					
1	24.75	20.75	50.25	25.53	0.508
2	24.35	20.35	49.88	28.50	0.571
3	24.74	20.74	49.60	27.30	0.550
4	24.4	20.48	49.35	25.92	0.525
Weld metal UTP-68HH "V"- type weld					
1	24.75	20.75	50.20	30.79	0.613
2	24.90	20.90	50.05	36.71	0.733
Weld metal UTP-68HH "K"- type weld (HAZ)					
1	25.20	21.20	50.05	24.00	0.480
2	25.21	21.21	50.0	31.90	0.638
3	25.20	21.20	50.05	25.48	0.509

### 3. INVESTIGATION OF 19Mn5 STEEL PIPE WELDED JOINTS FRACTURE TOUGHNESS

Fracture criterion for 19Mn5 steel pipes welded joints was taken  $J$ -integral and its critical value  $J_{Ic}$ , because definition of this criterion less depends on the sizes of the specimen to be tested. Procedure of  $J_{Ic}$  calculation is described in the Anderson (1991) and ASTM E1820-08 (2008).

Critical  $J$ -integral  $J_{Ic}$  values were defined using  $J$ - $R$  curve method, which results on developing curve of  $J$ -integral values at evenly spaced crack extensions  $\Delta a$ . Initial data for developing of  $J$ - $R$  curve is "force vs. load line displacement" ( $F$ - $\delta$ ) records. Monotonously increasing reloading force, by the means of high speed X-Y recorder and computer via oscilloscope, these records were given in a form as shown in Fig. 2.

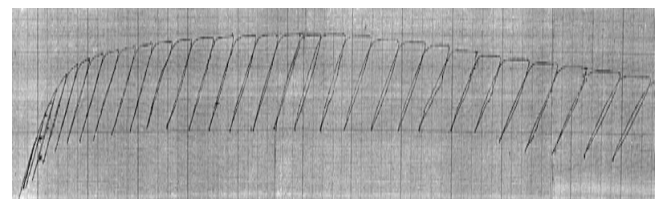
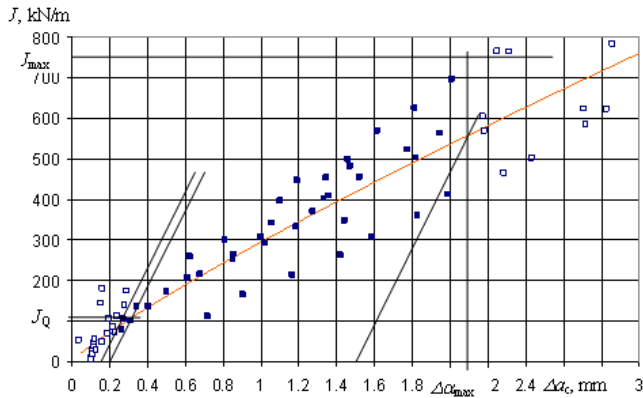

**Fig. 2.** Example of ( $F$ - $\delta$ ) curve record

Recorded ( $F$ - $\delta$ ) segments were used to calculate the increment of a crack length and corresponding to it  $J$ -integral values. Crack increment was calculated using elastic compliance method from loading/unloading segments unloading part compliance ( $C_i = \delta_i/F_i$ ) change, current  $J$ -integral values and  $J_{Ic}$  was calculated according to ASTM E1820-08, (2008).

It should be noted that compliance calculation is a very sensitive process, because the angles of the adjacent segments, from which the compliance tilt is calculated differs in a very negligible margin. Moreover, as showed

our experiment, compliance change during specimen loading/unloading was not enough stable process in that viewpoint, because especially in the initial stage of reloading, there was observed considerable compliance scatter, which may be the reason of saltatory crack grow with following its slow up in the next loading step. For this reason we had considerable difficulty in finding calculated compliance value, which results on  $J$ -integral calculation.



**Fig. 3.** Experimental fracture toughness data for “V”- type weld specimens welded by electrodes CT-36 and averaged  $J$ - $R$  curve (line)

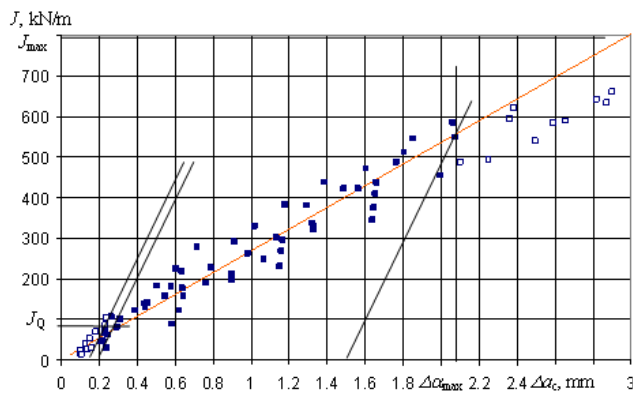

**Fig. 4.** Experimental fracture toughness data for “V” - type weld specimens welded by electrodes YONI-13/55 and averaged  $J$ - $R$  curve (line)

According to the testing programme, for each specimen in series  $J$ -integral values  $J_i$  and crack extension  $\Delta a_i$  were calculated and then  $J_i - \Delta a_i$  curve were plotted. The results of these calculations are presented in Figs. 3 – 6. According to (ASTM E1820-08, 2008),  $J$ - $R$  curves were established by smoothly fitting points to a power law regression line expressed as follows:

$$J = c_1 (\Delta a_p)^{c_2} \quad (1)$$

where  $c_1$  and  $c_2$  are the parameters of the equation of the region, limited by the given  $J_{max}$  and  $\Delta a_{max}$  and the exclusion line (2) derived from the point  $\Delta a_p=0.15$ mm.

$$J = 2\sigma_Y \Delta a_p, \quad (2)$$

where  $\sigma_Y$  is effective yieldstrength  $[\sigma_Y = (R_{p0.2} + R_m)/2]$ .

The maximum crack extension capacity was calculated by the equation

$$\Delta a_{max} = 0.1b_0 \quad (3)$$

Following to the recommendations of (ASTM E1820-08, 2008) were defined the parameters  $J_Q$ ,  $J_{max}$  and  $J_{Pmax}$ , which allow to evaluate stable ( $J_Q = J_{Ic}$ ), maximal ( $J_{max}$ ) and critical ( $J_{Pmax}$ ) crack growth. The  $J$ -integral value  $J_Q$  was defined at the intersection between the  $J$ - $R$  curve (Eq. 1) and the exclusion line (Eq. 2), derived from the point  $\Delta a_p=0.20$ mm.

If calculated  $J_Q$  values satisfied condition  $b_0 \geq (25J_Q/\sigma_Y)=B^*$ , it was assumed that  $J_Q = J_{Ic}$ .

As was noted before, the testing of welded specimens was characterized by the considerable scatter of the experimental results, thus thereafter  $J_{Ic}$  values were averaged of all tested specimens in each series.

Results of  $J$ -integral calculation are presented in Tab. 4.

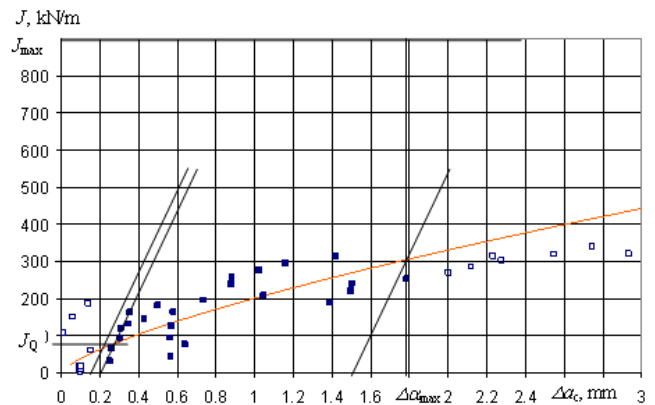

**Fig. 5.** Experimental fracture toughness data for “V”- type weld specimens welded by electrodes UTP-068HH and averaged  $J$ - $R$  curve (line)

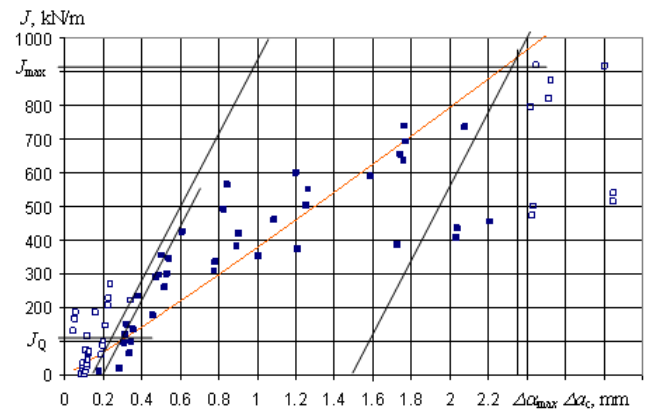

**Fig. 6.** Experimental fracture toughness data for “K”- type weld specimens (HAZ) welded by electrodes UTP-068HH and averaged  $J$ - $R$  curve (line)

**Tab. 4.** Results of  $J$  integral calculation

Weld material	$\Delta a_{max}$ , mm	$J_{Ic}$ , kN/m	$J_{max}$ , kN/m	$J_{Pmax}$ , kN/m
CT-36	2.09	108	742	606
YONI-13/55	2.08	79	791	481
UTP-068HH “V”- type weld	1.78	101	902	146
UTP-068HH “K”- type weld	2.34	100	918	643

The analysis of the results presented in Table 4 has showed that highest  $J_{Ic}$  values was given for the welds using electrodes CT-36, for which  $J$ -integral critical value comprises  $J_{Ic}=108\text{kN/m}$ , lower  $J_{Ic}$  values was given for the specimens welded using the electrodes UTP-068HH ( $J_{Ic}=101\text{kN/m}$ ) and lowest  $J_{Ic}$  ones was given for the specimens welded using electrodes YONI-13/55, for which  $J$ -integral critical value  $J_{Ic}$  was given  $79\text{ kN/m}$ .

The best resistance to the crack propagation at maximal load  $P_{max}$  was given for the specimens UTP-068HH with "K"-type weld ( $J_{Pmax}=643\text{kN/m}$ ), i.e. in the case, when a crack start and grow in the heat affected zone.

From the other side, comparison of the specimens with "K" and "V" – type welds has showed that resistance to the crack propagation in the heat affected zones is similar to the crack growth resistance in the weld zone and crack growth does not depends on weld type: for the specimens with "K" – type weld there was found  $J_{Ic}=101\text{kN/m}$  and for the specimens with "V"-type weld  $J_{Ic}$  comprise  $100\text{kN/m}$ . These results have showed that crack growth in the heat affected zone is the same like in the weld metal.

Summarising it could be concluded, that 19Mn5 steel pipe welded by electrodes CT-36 have better resistance to crack growth than joints welded by electrodes YONI-13/55 and UTP-068HH, thus in the case of a cracked main circulated circuit (MCC) pipeline repair, advantage should be taken to electrodes CT-36 in comparison with electrodes UTP-068HH and YONI-13/55.

Furthermore  $J$ - $R$  calculation data was used to define critical stress intensity factors range  $K_c^*$ , which was defined using maximal load  $P_c$  value taken from the graphs ( $F$ - $\delta$ ) (Daunys et al., 2005). This criterion represents fracture characteristic for the specimens of tested thickness (GOST 25.506-85, 1985).

Because the thickness of tested specimens in our experiment is near to the pipe thickness, given  $K_c^*$  values could be used to evaluate fracture toughness of the MCC pipeline from the positions of linear fracture mechanics as well. Comparison of stress intensity factor  $K_c^*$  range, calculated from ( $F$ - $\delta$ ) curves and  $J_{Ic}$  values, obtained from the experiment have showed satisfactory correlation (Table 5).

**Tab. 5.** Weld material fracture toughness characteristics

Weld metal	$K_c^*$ , MPa m <sup>1/2</sup>	$J_{Ic}$ , kN/m
CT-36 "V"- type weld	114,9	108
YONI 13/55 "V"- type weld	134,5	100
UTP-068HH "V"- type weld	91,7	79
UTP-068HH HAZ ("K"- type weld)	116,9	101

#### 4. CONCLUSIONS

1. Fracture toughness investigation of 19Mn5 steel pipe welded joints used in Ignalina NPP has showed that in the case of cracked MCC pipeline repair, advantage should be taken to the electrodes CT-36 in comparison with the electrodes YONI-13/55 and UTP-068HH; however difference to the crack resistance is quite negligible. It means that for the pipeline repair could be used all three types of electrodes as well.
2. For qualitative crack growth evaluation in the welds using electrodes CT-36, should be used  $J$ -integral critical value  $J_{Ic}=108\text{kN/m}$ , for the welds using electrodes UTP-068HH –  $J_{Ic}=101\text{kN/m}$  and for the welds using electrodes YONI-13/55  $J_{Ic}=79\text{kN/m}$ .
3. For calculated maximum crack extension  $\Delta a_{max}$  the maximal  $J$ -integral value was given for the joints welded using electrodes UTP-068HH and comprises  $J_{max}=902 - 918\text{MPa}$  in comparison with  $J_{max}=791\text{MPa}$  for the joints welded using electrodes CT-36 and  $J_{max}=742\text{MPa}$  for electrodes YONI-13/55.
4. The best resistance to the crack propagation at maximal load  $P_{max}$  was given for the specimens in the heat affected zone (UTP-068HH "K"-type weld), for which was given  $J_{Pmax}=643\text{ kN/m}$ .
5. Comparison of the specimens with "K" and "V" – type welds using electrodes UTP-068HH has showed that resistance to crack propagation in the heat affected zone is similar to crack growth resistance in the weld, therefore it could be concluded that fracture toughness for this weld material does not depends on weld type.

#### REFERENCES

1. **Anderson T. L.** (1991), *Fracture Mechanics. Fundamentals and Applications*, CRC Press, Boca Raton, Ann Arbor, Boston.
2. **Daunys M., Krasauskas P., Dundulis R.** (2005), Fracture Toughness of Welded Joints Materials for Main Pipelines at Ignalina NPP, *Nuclear Engineering and Design*, Elsevier, Lausanne, Vol. 235, Issue 7, 747-760.
3. Mechanical test methods of metals. Determination of fracture toughness characteristics under static loading (in Russian), GOST 25.506-85, (1985).
4. Standard Test Method for Measurement of Fracture Toughness, ASTM E1820-08, (2008).