

MICROELECTROMECHANICAL FLYING ROBOTS - STATE OF THE ART

Krzysztof SIBILSKI*

*Katedra Robotyki i Automatyki, Wydział Mechaniczny, Politechnika Białostocka, ul. Wiejska 45 C, 15-351 Białystok

sibilski@hot.pl

Abstract: Micro Air Vehicles (MAVs) are miniature airplanes constructed from state-of-the-art materials, designed to be small, light, and highly resilient. Current applications include surveillance, reconnaissance, and munitions. Many of the planes, because of their size, have unconventional designs with respect to the wings and control surfaces. Instability introduced by the small non-traditional aircraft designs must be addressed, to eliminate the need for an expert pilot for aircraft control and navigation. In this paper we present a state-of-the-art technology development focused on the technologies and components required to enable flight at small scales, including flight control, power and propulsion, navigation, multi-purpose structures, advanced communications and information systems, Micro-electro-mechanical Systems (MEMS), advanced sensors, and lightweight, efficient high-density power sources.

1. INTRODUCTION

The term “micro aerial vehicle” (MAV) can be a bit confusing, in the case this name is given a too literal interpretation. Usually it is assumed, that it is a model of an aeroplane treated as miniature, so the “micro” term regards a class of significantly small aircraft [12]. It should be emphasised, though, that microaeroplanes are not small versions of “big” aeroplanes. They should be treated an entirely new category of unmanned aerial vehicles. The definition created for the use of programmes finances by American DARPA agency states, that MAVs are flying vehicles of overall dimensions not greater than 15 cm (6 inches). Overall dimensions are understood here as wing span, height, length or width. From this stems the fact, that the objects belonging to this class are significantly smaller than other unmanned aircraft being developed or used nowadays. In other words “microaeroplane” is a kind of flying robot, characterised by high manoeuvrability, able to carry miniaturised devices and sensors to dangerous locations. This device can perform various missions: scouting, searching, determining contamination or carrying micro explosive charges.

Although limitation of microaeroplane dimensions to 15 cm can seem too arbitrary, it stems from physical and structural solutions and first of all from little Reynolds numbers of flow around wings. The range of small Reynolds numbers in which MAVs operate means a significant difference in physical processes accompanying their flight. Physics of flight of these aircraft is closer to aerodynamics and flight dynamics of birds and large insects than to that of aeroplanes.

Despite the fact that naturalists have been studying problems of insects and birds flight for over fifty years, until now many problems concerning their flight remain unexplained.

Performance, load capacity or manoeuvrability of modern unmanned aeroplanes is far lower than the performance and “load capacity” of bees and wasps or manoeuvrability of dragonflies. Therefore it could be stated, that until the physics of phenomenon accompanying flight in small Reynolds numbers is thoroughly determined, the flight capabilities of miniature aircrafts will be limited. In other words MAVs development apart from “theoretical” problems connected with modelling of their aerodynamics, flight control and dynamics, and generate a lot of serious technical problems. One of those is the integrations of systems mounted inside of the apparatus. Because of small size of the cargo space of a microaeroplane the distribution of the necessary devices, units and on-board sensors becomes an extremely serious problem. The conception used in “large” aeroplanes, consisting in filling the inside of the airframe with necessary instruments and then equipment – programme integration in this case is practically impossible. The scale of complexity of the problem of integration of MAV systems can be better understood while studying figure 1.

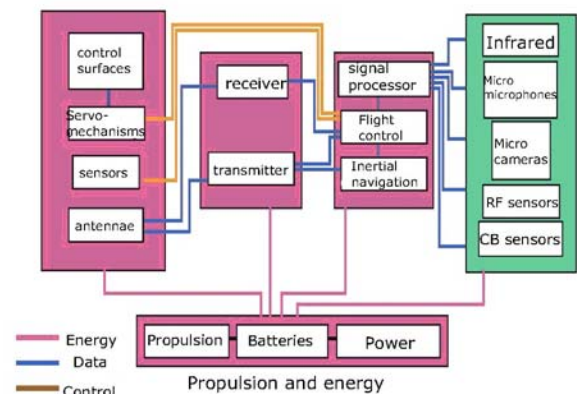

Fig. 1. Integration of MAV systems [22]

Many systems and subsystems presented in fig. 1 belong to the group of microelectrical and microelectromechanical devices. It should be noted, that even individual modules can be of bigger volume than the available one. From the electronic point of view the core of the microaeroplane are: on-board computer and communication modules. These elements are crucial links of a chain connecting the sensors mounted on the microaeroplane and the ground station. They also play the role of controllers of modules of stabilization and control of the flight and of the MAV propulsion system. On the diagram presented in fig. 1 the significant meaning of subsystems of power supply, energy storage and propulsion. Their role is not only providing the power necessary for performing the flight. They are also an energy source for all systems on-board of a microaeroplane. The required functionality of such aircrafts connected with small dimensions and little lift is a serious technological challenge. All systems mounted on them have to be characterised by very large scale of integration. The systems should also be multi-functional. Many of them have to comprise integral elements of airframe structure. And so e.g. the wings of microaeroplane have to be at the same time a system of antennae and be the location of sensors. The power source can be integrated with the fuselage, etc. The degree of "synergism" required when developing a microaeroplane is incomparably higher than the one obtained when designing a "conventional" aeroplane.

Probably the most difficult element of the MAV to design is the system of flight control, which should be highly autonomous and should operate instantaneously. Relatively strong forces and moments caused by laminar flow (in entire flight range) act on the microaeroplane. Moreover it is very difficult to foresee the conditions in which the flight will take place. Because of little mass and dimensions (moments of inertia) the effects of unsteady flow caused by gushes of the air and manoeuvres will significantly influence the aerodynamic loads of the microaeroplane. This is obvious because of extremely low unitary load of lifting surface of this aircraft.

The propulsion system of the microaeroplane has to be characterised by little dimensions and satisfy extremely high demand for power and energy, necessary for correct operation of systems installed on-board. Additional condition posed to the propulsion system is acoustic silencing of its operation. This is a necessary condition to ensure non-detectability of missions performed by the microaeroplane. Decrease of the necessary power can be obtained through decreasing the wing loading. This means increasing the wing surface and decreasing the mass of the microaeroplane. E.g. the famous human-powered aircraft (winner of Kramer award) Gossamer Albatross has gigantic wings (and at the same time little mass), therefore it can be propelled with seemingly insignificant power of human muscles. However, the dimensions of microaeroplanes are limited to 15 cm. Therefore, in this case, constructing "enormous" wings is impossible. The only way of increasing MAVs' wing surface is by increasing their chord, which in turn causes a decrease of their aspect ratio – and consequently problems with three-dimensional

flow. The use of microelectromechanical technologies, little demand for energy of highly integrated microelectrical systems, the use of multifunctional modules – these are the ways to radically decrease the energy demand.

Another problem in need of a solution is the MAV navigation. It seems that an almost perfect solution is the use of GPS. Alternatively, in the case of indoor mission when GPS signal is too small, inertial navigation systems can be used, because of the fact that miniature accelerometer and gyroscope platforms are available nowadays. For a microaeroplane to be a fully operational reconnaissance device it needs to be able to perfectly handle avoiding obstacles and finding path in the area of its flight. Therefore a condition necessary for correct operation of a MAV is equipping it with systems of artificial intelligence. It can be stated, that a reconnaissance MAV should be autonomously acting, flying cybernetic device. It should be remembered, that direct controlling of a microaeroplane by an operator will not always ensure flight stabilization (e.g. after encountering a gush of wind) nor will it cause avoiding of a suddenly appearing obstacle. Therefore MAVs have to operate autonomously in a large portion of their flight.

Another very serious problem is the maintenance of communication between the MAV and the operator. Because of the small dimensions of a MAV the antennae of this device are small, and maintenance of a wide-enough band of data transmission (2-4 Mbit/sec), necessary for transmission of image provided by a video microcamera is an extremely difficult task. Control functions require much narrower band of data transmission (of the order of 10 kbit/sec). Of course compression of images allows decreasing of the wideness of the data transmission band.

MAVs should be equipped with systems of sensors necessary for performing reconnaissance and supervisory missions. The sensors can include microcameras (acting in the visible range and infrared), radio wave receivers of multiple frequencies, biochemical sensors, radiation counters, microphones, etc. These sensors should be integrated with the MAVs systems. Nowadays, miniature video cameras, weighing 1 gram and having the resolution of 1000x1000 pixels and energy consumption of the order of 25 milliwatts are available. Specialists claim, that significant decrease of mass and dimensions of such video cameras is possible, with simultaneous increase of resolution.

2. BIOLOGICAL INSPIRATIONS OF MAV DESIGN

2.1. BIONICS, what it is *

Many MAV developers have opted for fixed wing or rotary wing aircraft designs but most analysts agree that the best solutions to building smaller MAVs closer to the centimeter-scale may be inspired from nature. Through the process of evolution, organisms have experimented with form and function for at least 3 billion

* This paragraph is summary of paper by prof Dickinson: (1999) [7]

years before the first human manipulations of stone, bone, and antler. Although we cannot know for sure the extent to which biological models inspired our early ancestors, more recent examples of biomimetic designs are well documented. For example, birds and bats played a central role in one of the more triumphant feats of human engineering, the construction of an airplane. In the 16th century, Leonardo da Vinci sketched designs for gliding and flapping machines based on his anatomical study of birds. More than 300 years later, Otto Lilienthal built and flew gliding machines that were also patterned after birds. Lilienthal died in one of his own creations, in part because he failed to solve a difficult problem for which animals would eventually provide another critical insight: how to steer and maneuver. The wing warping mechanism that enabled Orville and Wilbur Wright to steer their airplane past the cameras and into the history books is said to have been inspired by watching buzzards soar near their Ohio home. It is perhaps not surprising that early aeronautical engineers were inspired by Nature given that the performance gap was so large and obvious. Because birds can fly and we cannot, only the most foolhardy or arrogant individual would design a flying craft without some reference to natural analogs. Most engineering projects, however, take place successfully without any explicit reference to Nature, in large part because natural analogs do not exist for most mechanical devices. One would need to search far and wide for a natural analog of a toaster. Nevertheless, in recent years there seems to be growing interest on the part of engineers to borrow design concepts from Nature. The discipline has grown to the point that books, articles, conference sessions, and university programs labeled Bionics or Biomimetics are quite common. In the case of aerodynamics, biomimetic approaches appeal to roboticists, because the performance gap between mechanical devices and their natural analogs is so large. One reason for the growing interest in Bionics is that fabrication methods are much more sophisticated than they used to be. Because of innovations in Materials Science, Electrical Engineering, Chemistry, and Molecular Genetics, it is possible to plan and construct complicated structures at the molecular or near molecular level. Examples include buckyballs, nanotubes, and the myriad of microelectromechanical devices (MEMs) constructed with technology derived from the silicon chip industry. Integrated circuits themselves play a role in Bionics projects aimed at constructing smart materials or mimicking the movement, behavior, and cognition of animals. In short, biological structures are complicated, and we are only now beginning to possess a sophisticated enough tool kit to mimic the salient features of that complexity.

Another reason for the increasing popularity of Bionics is simply that we know much more about how plants and animals work than we used to. The overwhelming success of Biology, practiced at the cellular and subcellular levels, has overshadowed many substantial advances in our knowledge of processes that operate at higher levels of biological complexity. Taking examples from studies on animal locomotion, biologists now understand how basilisk lizards walk on water, how penguins minimize drag, and how insects manage to remain airborne, phenomena that,

until recently, were poorly understood. The solutions to such puzzles do not impact the world of Science as does, say, sequencing the human genome. They do, however, identify specific structure - function relationships, and, as such, can provide assistance to engineers faced with analogous problems. The fields of Biology that use principles of Structural Engineering and Fluid Mechanics to draw structure - function relationships are Functional Morphology or Biomechanics. These disciplines are of particular use to Bionics engineers, because the behavior and performance of natural structures can be characterized with methods and units that are directly applicable to mechanical analogs. The result of precise spatial and temporal regulation is a complex exoskeleton that is tagmatized into functional zones. Limbs consist of tough, rigid tubes made of molecular plywood, connected by complex joints made of hard junctures separated by rubbery membrane. The most elaborate example of an arthropod joint is the wing hinge, the morphological centerpiece of flight behavior (see fig. 2). Fig. 2 shows hinges system of flying insects. The horizontal hinge ① occurs near the base of the wing next to the first axillary sclerite. This hinge allow the wing to flap up and down. The vertical hinge ② is located at the base of the radial vein near the second axillary sclerite (2AX), and is responsible for the lagging motions of wing. The torsional hinge ③ appear to be more complicated interaction of sclerite and deformable folds.

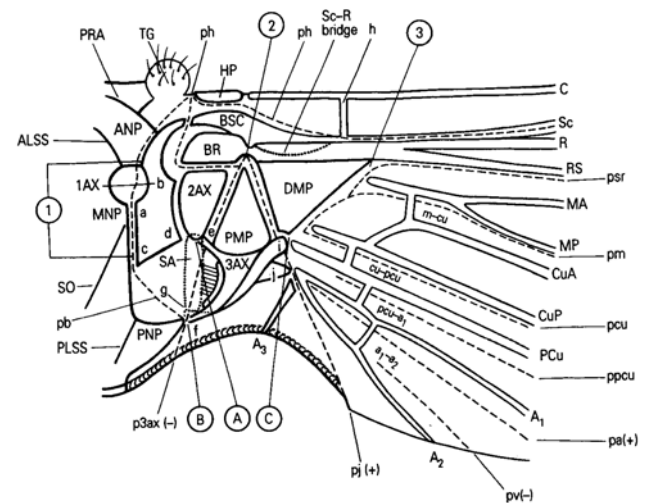

Fig. 2. Insect Axillary Apparatus. Region at the base of the wing containing all the intricate mechanical components. First axillary sclerite (1AX), articulates with the anterior notal process and forms the horizontal hinge. Second axillary sclerite (2AX) articulates with an extension of the thoracic wall. The 2AX is responsible for the pleural wing process (PWP), and support the radial vein, (main mechanical axis for the wing). Third axillary sclerite (3AX) is responsible for wing flexing, and play role of the vertical hinge.

The hinge consists of a complex interconnected tangle of five hard sclerotized elements, imbedded within thinner, more elastic cuticle, and bordered by the thick side walls of the thorax. In most insects, the muscles that actually power the wings are not attached to the hinge. Instead, flight muscles cause small strains within the walls of the thorax, which the hinge then amplifies into large oscillations of the wing. Small control muscles attached

directly to the hinge enable the insect to alter wing motion during steering maneuvers. The indirect muscles do not directly effect wing. They are attach to the tergum, and distort the thoracic box when contracted. This distortion transmits forces to the wing. There are two bundles of indirect muscles: dorsolongitudinal (DLM), and dorsoventral (DVM). The dorsolongitudinal muscles span the length of the tergum, the dorsoventral muscles extend from the tergum to the sternum. The direct muscles connect directly from the pleuron (thoracic wall) to individual sclerites located at the base of the wing. The subalar and basalar muscles have ligament attachments to the subalar and basalar sclerites. Resilin is a highly elastic material and forms the ligaments connecting flight muscles to wing apparatus, and it is 100 times greater energy storage capabilities than muscle. There are other muscles that are directly inserted into the first and third axillary sclerite (see fig. 3)

Although the material properties of the elements within the hinge are indeed remarkable, it is the structural complexity as much as the material properties that endow the wing hinge with its astonishing characteristics. Sometimes it is not the actual morphology that endows a biological structure with its functional properties, but the intelligence with which it is used. Intelligence does not necessarily imply cognition; it may simply reflect the ability to use a structure in an efficient and flexible manner.

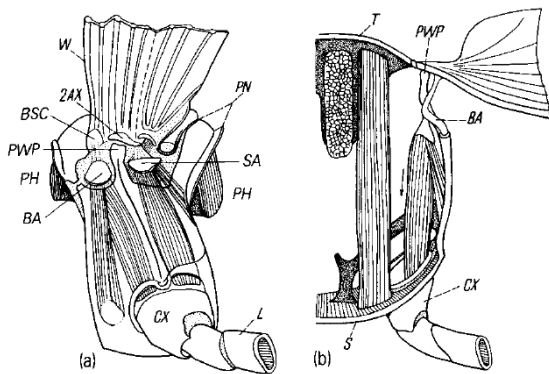

Fig. 3 The direct flight muscles within the wing bearing segment: (a) lateral view; (b) cross-sectional view.

Although most biological structures are not intelligent by human standards, they nevertheless outperform most bricks and I - beams. A good example is the insect wing (fig. 4). The wing is the structure with membranous cuticle stretched between veins in the wing. Unlike an aircraft wing, it is neither streamlined nor smooth. Folds facilitate deformation during flight. Veins increase the mechanical rigidity of the wing (alternate in concave and convex patterns). Radial vein is the longitudinal rotational axis of the wing, about which occur pronation and supination.

Engineers and biologists have long struggled to explain how a bumblebee (or any insect) remains in the air by flapping its wings. Conventional steady-state aerodynamic theory is based on rigid wings moving at a uniform speed. Such theory cannot account for the force required to keep an insect in the air. The solution to this paradox resides not in the intrinsic properties of wings,

but rather in the way that insects use them. By flapping the wings back and forth, insects take advantage of the unsteady mechanisms that produce forces above and beyond those possible under steady-state conditions. Several research groups are actively attempting to construct miniature flying devices patterned after insects. Their challenge is not simply to replicate an insect wing, but to create a mechanism that flaps it just as effectively. Intelligent structures do not always function the same way; they adapt to local functional requirements. Even the simplest plants and animals sense their world, integrate information, and act accordingly. Feedback-control mechanisms are extremely important features that endow organisms with flexibility and robustness. Even plants, which lack a nervous system, can nevertheless grow leaves and branches toward light, roots toward water, or spatially regulate growth so as to minimize mechanical stress. The functions of biological structures cannot be fully understood or accurately mimicked without taking this complex dynamic feedback into account. Of all the properties of biological entities (with the possible exception of self-replication), it is their intelligence and flexibility that is perhaps the most difficult to duplicate in an artificial device. The next decade should be exciting for the field of Bionics. Just as biologists are discovering the structural and physiological mechanisms that underlie the functional properties of plants and animals, engineers are beginning to develop a fabrication tool kit that is sophisticated enough to capture their salient features. As the performance gap between biological structures and our mechanical analogs shortens, engineers may feel increasingly encouraged to seek and adopt design concepts from Nature. Although the devices they construct may at first appear alien, their origins in the organic world may endow them with an odd familiarity.

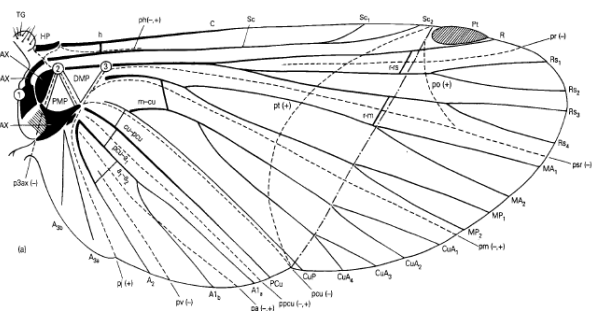

Fig. 4. The insect wing layout

As it was discussed, biological flying insects use flapping wings to attain amazing capabilities for hovering and maneuvering. Most of the recent work on Biological Micro Aerial Vehicles (BMAVs) has been on the scale of avian flight which is quite different from insect flight. Notable examples in this list include the Caltech RTCLA Omithopter (Pornsir-Sirirak et al [30]), the Delf University of Technology (R. Ruijsink) [www.delffly.nl], the Georgia Tech Entomopter (Michelson) [23, 24], the Arizona University (Shkakarjev) [18], the France ROBUR project [6, 19]. The UC Berkeley developed the Micromechanical Flying Insect (MFI) project. This BMAV distinguishes itself with a wingspan of only 25 mm, almost an order

of magnitude smaller than all the others (this translates into roughly three orders of magnitude difference in mass). The work on the MFI has been documented in a number of areas including design and fabrication, actuator development, thorax dynamics, sensing, and aerodynamic simulation [13, 32, 33, 34, 46, 47].

The success of insect-scale BMAVs depends on exploitation of unsteady aerodynamic mechanisms (in particular, delayed stall, rotational lift, and wake capture) which have only recently been elucidated by Dickinson et al [7, 8]. There has been some success with computational methods to estimate forces generated by flapping wings [9, 10, 29, 32, 36] but both the models and algorithms need to be improved in order to get better agreement with experimental values. The only reliable means to determine the forces generated by the flapping wing is to measure them directly.

Current works on MAV with flapping wings required introduction of a new notion, animalopter. Animalopter means a flying object constructed by man, which flies in a way similar to natural animalopters (i.e. like natural creatures: birds, insects and bats), i.e. by moving wings. For this reason we shall avoid the name microaeroplane, which as a rule means a device with immobile wings. Therefore we are dealing with an *entomopter*, if it is an artificial insect, or an *ornitopter*, if we are dealing with an artificial bird.

Wings of an animalopter are a multifunctional device, which create not only the aerodynamic lift, but also thrust, and, last but not least, can control the flight. Because of the complex equipment mounted on the animalopter, it can be stated, that the animalopter is a *flying micro-electro-mechanical robot*.

Animalopter is of dimensions similar to the dimensions of a small bird (or a bat) and a large insect. The thing that distinguishes animalopter from an ordinary radio-controlled small aeroplane are air operations, usually beyond the operator's sight range and on *small* Reynolds numbers (of the order of ten to a hundred thousand). The data of how the motion of wings and the body change during flight is interesting not only *per se*, but also in order to understand the mechanisms, which take place during flight and their mathematical modelling.

If one wanted to search for analogies with artificial objects, then because of the complex motion in relation to the body, animalopter is more similar to a helicopter than to an aeroplane. Therefore many concepts stemming from helicopter flight mechanics found use in flight biomechanics, of course after taking into account animalopters' specificity.

Bird's wing anatomy is quite well known and described. Feathers create a lifting surface with a highly complex structure and shape, which causes the entire wing to become a lifting surface of elastic and permeable profile, with numerous vortex diffusers, such as down and elastic feather radiuses. Moreover appropriate motions of the wings enable a change of their span, lift and sweep during flight, and motions of muscles and tendons inside the wings enable among others a change of camber of a wing profile. Analogously to insects, birds are also able to actively control the flight. Thanks to appropriate wing motions and

arrangement of feathers they control the flow around the wings. The aim of this action, as in the case of insects, is minimalising of power needed for flight, reaching maximal velocity or manoeuvrability, or fulfilling the requirements of flight in special conditions.

2.2. Flapping wings degrees of freedom

Insect wing motion appear to be not simply up and down. It is much more complex (see fig. 5). Fig. 5 shows insect's wing tip trajectory. Such complex motion can be considered as being composed of three different rotations: flapping, lagging, feathering, and spanning. Flapping is a rotary motion of the wing around the longitudinal axis of the animalopter (this axis overlaps with the direction of flight velocity). Thus "up and down" motion is realised. Lagging is a rotary wing motion around the "vertical" axis, i.e. it describes "forward and backward" motion. Feathering is a rotary motion around longitudinal wing axis. During that motion changes of attack angle of the wing occur.

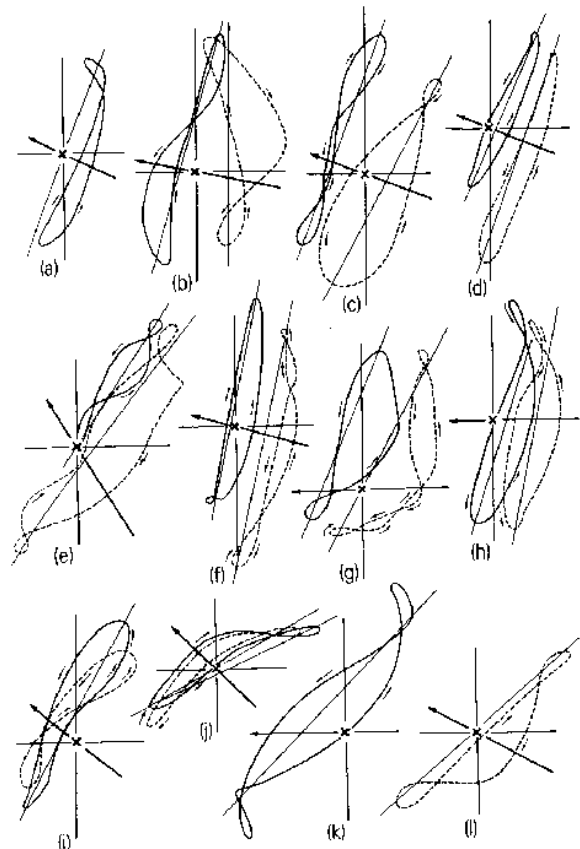

Fig. 5. Wingtip trajectories

Detailed analyses of kinematics are central to an integrated understanding of animal flight [1, 2, 8, 9, 10, 17, 20, 21, 25, 26, 27, 28, 32, 35, 37, 38, 39, 40]. Concluding, four degrees of freedom in each wing are used to achieve flight in the Nature: flapping, lagging, feathering, and spanning. This requires a universal joint similar the shoulder in a human. A good model of such joint is the articulated rotor hub (Fig. 6). *Flapping* is a rotation of a wing about longitudinal axis of the body (this axis lies in the direction of flight velocity), i.e. "up and

down" motion. *Lagging* is a rotation about a "vertical" axis, this is the "forward and backward" wing motion. *Feathering* is an angular movement about the wing longitudinal axis (which may pass through the wing center of gravity). During the feathering motion the wing changes its angle of attack.

Similar to insets, the motion of a bird wing may be decomposed into: *flapping*, *lagging*, *feathering* (the rigid body motions) and also into more complex deflections of the surface from the base shape (*vibration modes*).

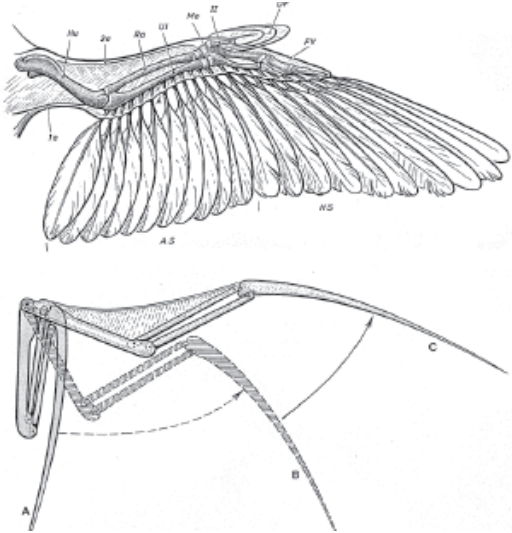

Fig. 6. Bird wing hinges anatomy, and wing folding

Insects with wing beat frequencies about 20 Hz generally have very restricted lagging capabilities. Insects such as alderfly (*Apatele alni*) and mayfly (*Ephemera*) have fixed stroke planes with respect to their bodies. Thus, flapping flight is possible with only two degrees of freedom: flapping and feathering. In the simplest physical models heaving and pitching represent these degrees of freedom. *Spanning* is an expanding and contracting of the wingspan. Not all flying animals implement all of these motions. Unlike birds, most insects do not use the spanning technique.

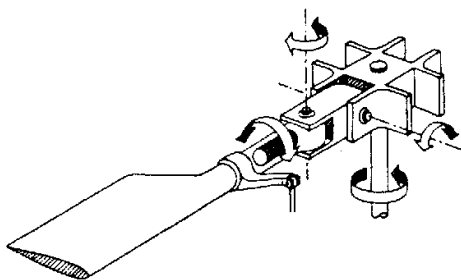

Fig. 7. Articulated joints of a helicopter main rotor

Spanning is a motion, which causes changes of wing aspect ratio. Not all animalopters use these motions. Unlike the birds, most insects do not use this technique. A significant question arises: which of these motions should be taken into account to obtain adequate description?

During level flight a bird has to flap its wings to generate aerodynamic lift and thrust to overcome

terrestrial gravity force and drag. Instantaneous forces on the wings change during the cycle because of the changes of wing shape, deformability of joints, attack angle, turning of the wings, rotary velocity of the wings, elastic properties, flight velocity etc. A key issue here is the understanding of how complex motions of so complicated object generate aerodynamic forces. No wonder, that aerodynamics of flapping wings is thought to be the most difficult field of aeroplane and helicopter aerodynamics. The issue is further complicated by the fact, that this is an aerodynamics of small Reynolds numbers. It also needs to be emphasized, that conventional flight mechanics can only be a guide and not an authority while analysing animalopters' flight dynamics. It is enough to realise, that the moments of inertia of movable parts change, and, moreover, the changes are different on each wing. Geometric parameters also undergo changes, e.g. wing aspect ratio. Stabilization of motion is a serious problem. A way to understand animalopters' motion is a thorough kinematic, which is connected with the choice of levels of freedom. An extremely serious problem is controlling such an object. This is caused by the fact, that wings do not have typical control surfaces, like ailerons (not to be confused with a kind of feathers!). Influencing the motion is possible only by changes of amplitudes and frequencies of flapping and turning the wings. It has been observed, though, that animalots are capable of performing incredible acrobatic manoeuvres, which would not be possible without appropriate "control devices". Knowledge on this topic is in the process of being gathered.

Insects fly by oscillating (plunging) and rotating (pitching) their wings through large angles, while sweeping them forwards and backwards. The wingbeat cycle (typical frequency range: 5–200 Hz) can be divided into two phases: downstroke and upstroke (see Fig. 8a).

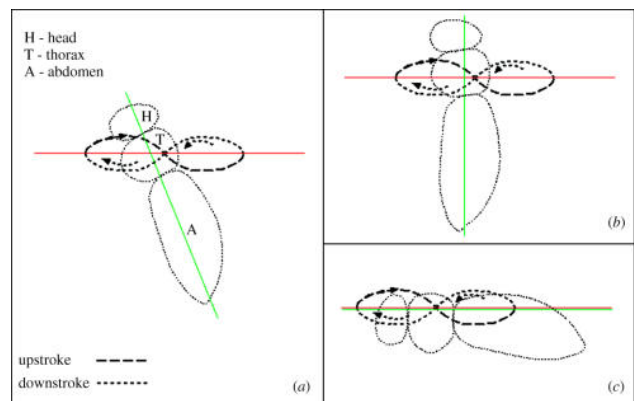

Fig. 8. Generic kinematics of insect in hover: the wing tip traces a 'figure-of eight', when seen from the insect side. The angle between the insect body axis (green) and the stroke plane (red) is constant. Typically, (a) the angle is steep; (b) one extreme: the angle is $\pi/2$; (c) the other extreme: the angle is zero (see Żbikowski and Galiński [48]).

At the beginning of downstroke, the wing (as seen from the front of the insect) is in the uppermost and rearmost

position with the leading edge pointing forward. The wing is then pushed downwards (plunged) and forwards (swept) continuously and rotated (pitched) at the end of the downstroke, when the wing is twisted rapidly, so that the leading edge points backwards, and the upstroke begins. During the upstroke, the wing is pushed upwards and backwards and at the highest point the wing is twisted again, so that the leading edge points forward and the next downstroke begins.

Insect wing flapping occurs in a stroke plane that generally remains at the same orientation to the body. The actual angle corresponding to the orientation is an interesting design parameter, (see Fig. 8b, and 8c).

In hover the downstroke and upstroke are equal, resulting in the wing tip approximately tracing a figure-of-eight (as seen from the insect's side). However, the figure-of-eight is not necessarily generic, as other, less regular, closed curves with more than one or no self-intersections are also observed [48]. For two-winged flies (Diptera) a 'banana' shape seems to be common. However, even for Diptera the kinematics in hover can be more complicated, so we settled on the figure-of-eight as 'commonly occurring' for reference purposes.

Since each half-cycle starts from rest and comes to a stop, the velocity distribution of the flapping is non-uniform, making the resulting airflow complex. It is also unsteady, i.e. the aerodynamic force varies in amplitude and direction during each wingbeat cycle. The variability of the force is compounded by the strong influence of the viscosity of air (owing to the small scale) and significant interaction of the wing with its wake (owing to hover). Finally, it is worth mentioning that the thorax-wing system in true flies (Diptera) is resonant, which contributes to the efficiency of propulsion. This feature was not implemented in the presented mechanism, but it is considered for a future design in the form of electro-mechanical resonance [zb].

2.3. Insect wing kinematics and propulsion

Insect wing kinematics are essentially spherical, while the trace of the wing tip is usually photographed from the insect's side. The result is an orthogonal projection of the spherical trace on to the plane of the animal's longitudinal symmetry. The resulting planar figure for a hovering insect's wing is always closed. As far as can be discerned from the available (noisy) data, e.g. for flies, the actual shape may be a figure-of-eight or a banana shape, but can be irregular and sometimes the trace has no self-intersections. Owing to the inherent experimental difficulties, the kinematic and aerodynamic data from free-flying insects are sparse and uncertain, and it is not clear what aerodynamic consequences different wing motions have, despite notable progress (e.g. Dickinson et al. 1998; Lehmann & Dickinson 1998; Lehmann 2004). Since acquiring the necessary kinematic and dynamic data remains a challenge, a synthetic, controlled study of insect-like flapping is not only of engineering value, but also of biological relevance.

There are two phases in each half-cycle of the wing beat: translational (wing moving forwards or backwards) and

rotational (at the end of each stroke). In order to clearly investigate the distinct aerodynamic contributions of each phase, the angle of attack should be constant during translation and rotate through at least 90° during the flip-over. Thus, theoretically attractive kinematics should entail an intermittent rotational motion with reversal. A more subtle aspect is the plunging (up-down) component of flapping. Every time a hovering wing starts (or stops) it sheds a starting (stopping) vortex (Wagner 1925; Zbikowski 2002b) which is then convected according to the airflow evolution. Despite the convection, such a vortex may persist in the vicinity of its original shedding point when the wing revisits that point in the next half-cycle. Then the wing and the vortex will collide and the flow structure is impaired. However, if the wing plunges up and down while moving forwards and backwards, it may be able to avoid hitting the vortex when revisiting the shedding point. In other words, figure-of-eight kinematics with the width of the 'eight' corresponding to the extent of plunging can plausibly be advantageous for aerodynamic reasons. Hence the focus of this work has been idealized wing tip kinematics of that type, so that the results are practical to implement, but scientifically relevant both for engineers and biologists.

Zbikowski and Galinski proposed to implement wing tip kinematics as a spherical, symmetric, self-intersecting curve, which would admit a convenient mathematical description and a simple engineering realization. They considers two options: a) Bernoulli's lemniscate and b) spherical Lissajous curves [48] – see fig. 9.

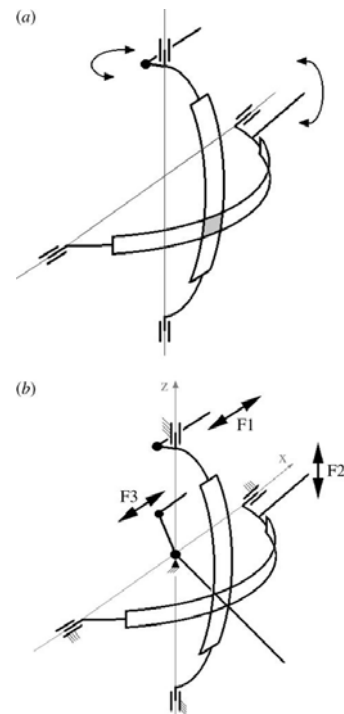

Fig. 9. Spherical double Scotch yoke: (a) kinematic diagram; (b) concept of the associated flapping mechanism (cf. Zbikowski and Galinski [48])

A spherical figure-of-eight together with decoupled pitching is easily obtainable if each of them have a common apex and if both Scotch yokes are orthogonal.

This combination allows the creation of Lissajous' curves if yokes are driven by sinusoidal inputs, one twice as fast as the other. As a result, a smooth figure-of-eight motion can be obtained, without any excessive accelerations, thus decreasing dynamic loads. The first step was to propose a planar mechanism capable of converting rotary input into reciprocal motion of the figure-of-eight type. This was done by combining orthogonally two Scotch yokes, so that Lissajous curves were generated. The drawbacks of the planar double Scotch yoke, can be avoided if the yokes are made spherical and their translation is exchanged with their rotation. In this configuration, both ends of each yoke are rotated about the same axis, see figure 9a. The figure-of-eight generated is then spherical by default, significantly simplifying wing articulation, see figure 9b [48].

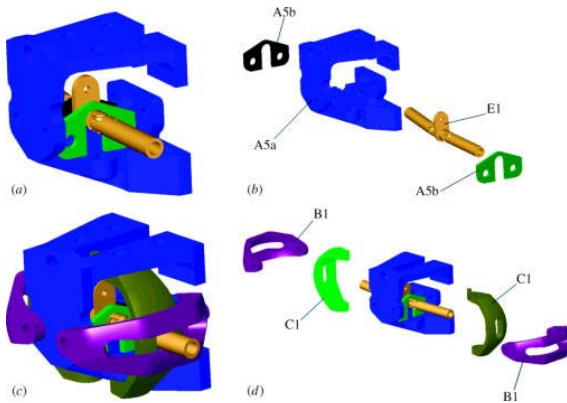

Fig. 10. Practical realization of spherical double Scotch yoke (Zbikowski and Galinski [48])

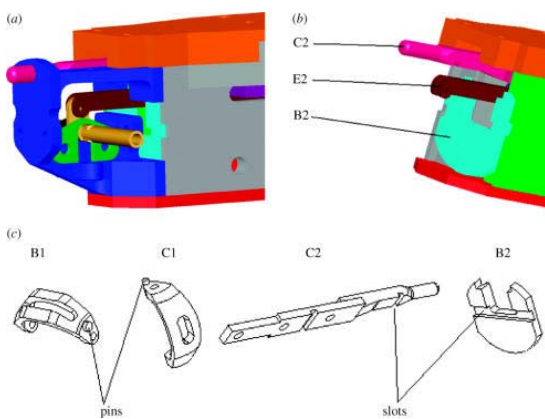

Fig. 11. Details of the driving components [48]

A practical realization of spherical double Scotch yoke realized by Dr Zbikowski and Dr Galinski (Cranfield University and Warsaw University of Technology) is shown in Fig. 9, and 10. Axle E1 (fig. 9) is attached to frame component A5a by two plates A5b, (fig. 10) so that a mode of slide bearing is created. The axle is equipped with two universal joints for wing articulation and a lever for pitch control. Wings can be attached to the tubes at both axle ends. Yokes C1 and B1 are also attached to frame component A9, so that their axes cross in the centre of the

universal joint. The mechanism contains two universal joints and two sets of yokes, to which two wings are to be attached. Universal joints cannot have a common centre, since the lever and attachment bearings have to be located between them.

The kinematics of an insect-like flapping wing for MAVs requires three-dimensional motion which is essentially spherical in character. Spherical double Scotch yoke is a relatively simple mechanism, complying with this requirement and realizing the required figure-of-eight as a spherical Lissajous' curve.

The spherical double Scotch yoke mechanism on the MAV scale was designed, manufactured, assembled and tested. It was found to be quite reliable and met its specifications, performing satisfactorily in tests and generating useful data for further aeromechanical studies. The few problems discovered in the course of the testing are minor and can be resolved by viable modifications.

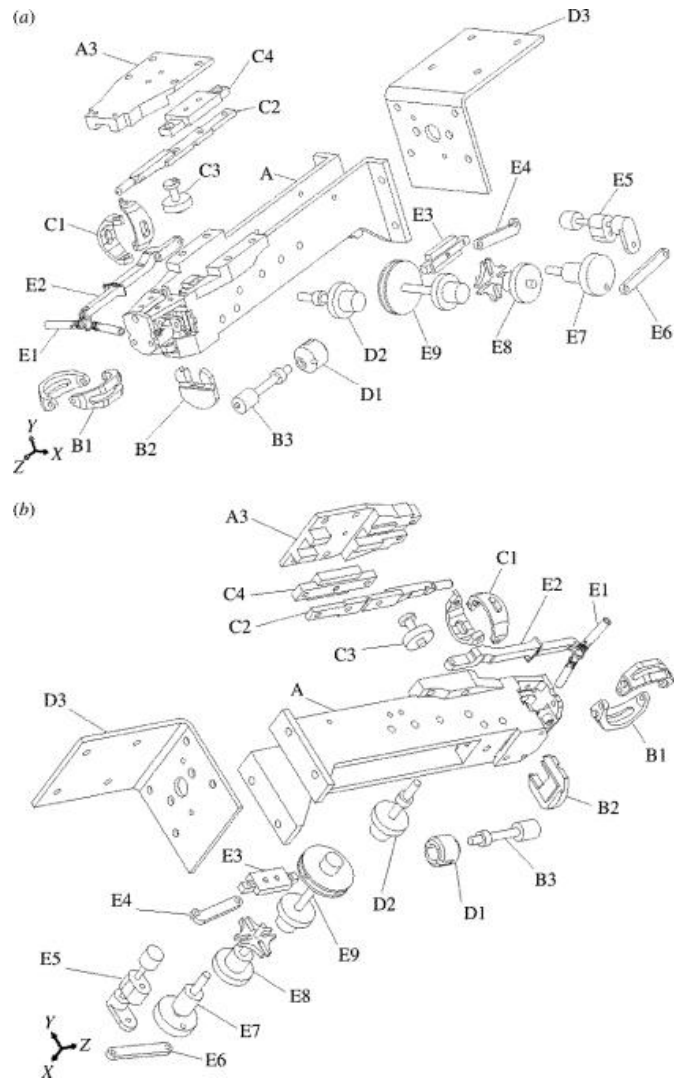

Fig. 12. The exploded view of the complete mechanics

The exploded view of the complete mechanism are presented in figure 12, and a photograph of the assembled mechanism is given in figure 13.

Fig 14 shows another example of mechanical design of flapping wings propulsion. This mechanism contains two rod-crank parallel mechanisms. It is characterized by minimum energetic consumption for a sinusoidal movement. Other kinematics are possible. Propulsion system 4 brushless motors (30 W, 100g), 0-5 Hz. Symmetrical movements - dihedral ± 50 deg, twist ± 30 deg. Dipteran insects drive their wing using indirect flight muscles attached to the exoskeleton dorsally and a deformable section of the exoskeleton called the scutum ventrally. Muscle activation works to depress the scutum while the pleural wing process is attached to the interface of the scutum and exoskeleton. This structure, shown in Fig. 1, is actuated by two sets of muscles: the dorsoventral and dorsolongitudinal muscles. The dorsoventral muscles act to depress the scutum and thus generate the 'up-stroke'. The dorsolongitudinal muscle acts to shorten the thorax and return the scutum to its relaxed state and thus generates the 'down-stroke'.

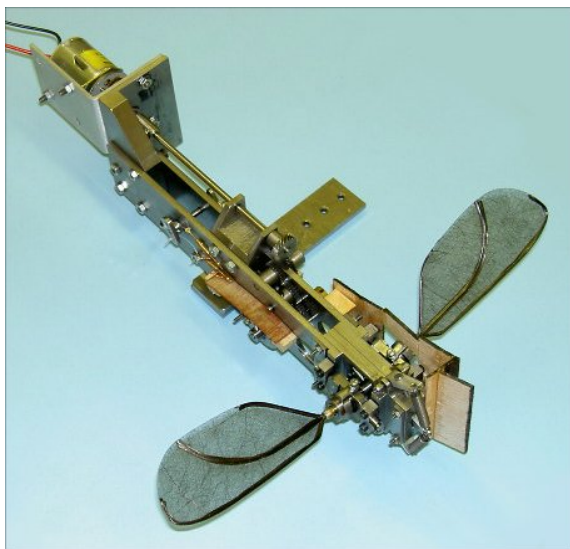

Fig. 13. General view of the Dr. Zbikowski complete mechanism

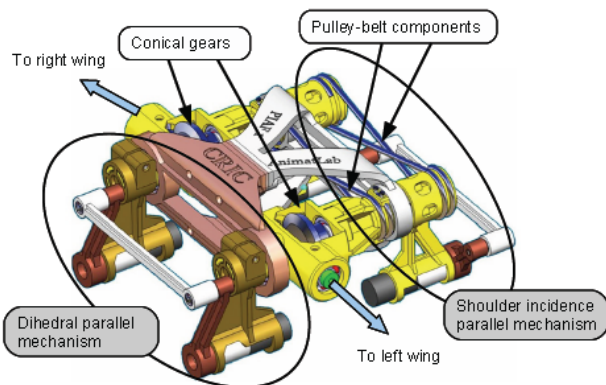

Fig. 14. ROBUR wing propulsion gearbox

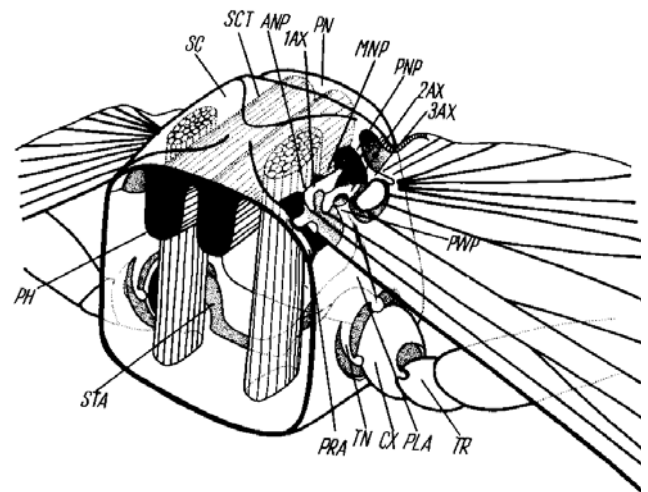

Fig. 15. Simplified diagram of Dipteran wing transmission

Kinematically, the structure in Fig. 15 is essentially a four-bar with a prismatic joint at the input. What is presented here is nearly identical: linear actuator motion is coupled to the wing hinge via a simple transmission which acts to convert this motion to a large flapping rotation at the wing hinge. Thus all the actuator power is used to drive the wings through as large a wing stroke as possible. Additionally, the wings are allowed to rotate along an axis parallel to the span-wise direction. This rotation is passive, but is key to generating lift.

A transmission mechanism is used to transform small actuator motions to large angular wing displacements and to impedance-match the actuator to the load (work done on the surrounding air). There are numerous reasons a large wing stroke is desired: for a given operating frequency a larger stroke amplitude will result in larger instantaneous wing velocities. Also, a larger stroke allows vortices to fully form and stabilize before the stroke reversal. At a 'macro' scale, this would be accomplished with a gear system. At the scale of an insect, it is not feasible to produce gears with the necessary efficiency, thus an alternative solution is presented here that is based on low-loss flexure joints.

Significant advances in mesoscale prototyping are enabling rigid, articulated, and actuated microrobotic structures. The robot fly designed by prof. Wood's team can be a good example of an elegant manufacturing paradigm, employed for the creation of a biologically inspired flapping-wing micro air vehicle with similar dimensions to Dipteran insects. Prof Wood designed a novel wing transmission system which contains one actuated and two passive degrees of freedom. The design and fabrication are detailed and the performance of the resulting structure is elucidated highlighting two key metrics: the wing trajectory and the thrust generated. Construction of the transmission is an exceedingly crucial step. The kinematics and dynamics of the transmission depend strongly upon the concise geometry of each link and flexure. The assumption that it is possible to use a pseudo-rigid-body technique assumes that all joints are properly aligned. To put this in perspective, the smallest link in the transmission system is 300 μ m in length and the

flexure lengths are $80\mu\text{m}$. Alignment is controlled by the precision stages of the laser-micromachining system. Fig. 16 shows the resulting transmission system which converts a small linear motion to large angular wing strokes.

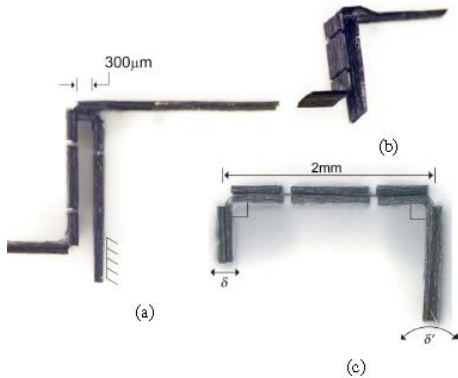

Fig. 16. Designed by prof. Wood MAV transmission system, top view (a) and isometric view (b). The slider-crank for coupling actuator motion to the prismatic input of the transmission is shown in (c) (cf. 44)

The actuators are constructed using the SCM process. In this case, some of the laminae are piezoelectric, thus resulting in bending moments upon the application of an electric field. Fig. 16 shows a completed microactuator.

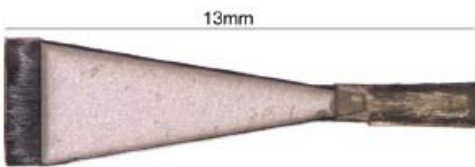

Fig. 17. High energy density piezoelectric bending cantilever [43, 44]

The actuator, wings, and transmission are assembled together onto an acrylic fixture that is created with a three dimensional printer. Care is given to the strength of the mounts so that a solid mechanical ground is established. Detail of the completed structure is shown in Fig. 18.

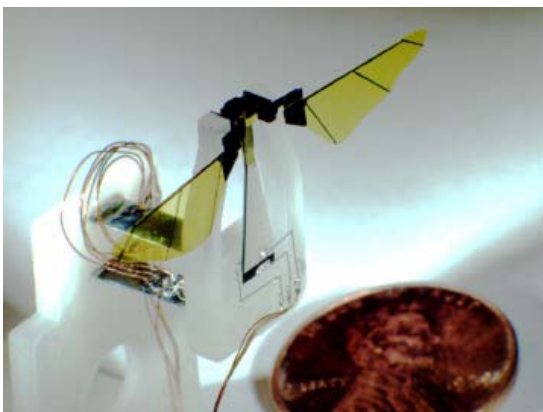

Fig. 18. Completed MAV test fixture mounted to a high sensitivity force transducer (cf. [42 – 44]).

2.4. Development of the wing trajectory

The actuated DOF is driven through as large a motion as possible. This is done open-loop with a sinusoidal drive at the resonant frequency. The measured resonant frequency is 110Hz , resulting in an actuator power density of approximately 165W/kg (comparable to good macro-scale DC motors). This is lower than the predicted resonant frequency of 170Hz , most likely due to unmodeled offsets in how the wing is mounted to the transmission. Fig. 18 details the wing motion that this structure can achieve. Note that this motion is qualitatively identical to hovering Dipteran insects. C. Wing force Because of the small force magnitude and high operating frequency, measuring the thrust produced by the wings in real time (with sub-period temporal resolution) is not trivial. A custom sensor was created specifically to measure this force. The design attempts to reconcile two opposing traits: high bandwidth and high sensitivity. To quantify this, the bandwidth of the sensor is desired to be at least $5\times$ the wing drive frequency with a resolution of less than 1% of the weight of the structure. For the details of the design, the reader is directed to [17]. The sensor itself is a parallel cantilever constructed from spring steel with semiconductor strain gages. The completed sensor has a resonant frequency of 400Hz (with the structure attached; slightly lower than desired), and a resolution of approximately $10\mu\text{N}$. The structure is fitted to the distal end of the sensor and the device is actuated, starting from rest. The average lift is measured by averaging 50 wing beats after 50 wing beats are elapsed to allow stable periodic vortex formation. The average lift was collected from 10 trials giving an average of $1.14\pm 0.23\text{mN}$. This would be sufficient to lift a fly weighing over 100mg . A typical time trace of the lift is shown in Fig. 9 for a drive magnitude of 100V peak.

The Harvard Microrobotics lab has recently demonstrated the first step towards recreating these evolutionary wonders with the world's first demonstration of an at-scale robotic insect capable of generating sufficient thrust to takeoff (with external power). The mechanics and aerodynamics of this device are quite similar to Dipteran insects. Biologists have recently quantified the complex nonlinear temporal phenomena that give insects their outstanding capabilities. Periodic wing motions consisting of a large stroke and pronation and supination about an axis parallel to the span-wise direction are characteristic of most hovering Dipteran insects. Previous microrobot designs have attempted to concisely control each wing trajectory in these two dimensions. The robot that is shown here has three degrees-of-freedom, only one of which is actuated. Here, a central power actuator drives the wing with as large a stroke as possible and passive dynamics allow the wing to rotate using flexural elements with joint stops to avoid over-rotation. There are four primary components to the mechanical system: the actuator (or 'flight muscle'), transmission (or 'thorax'), airframe (or 'exoskeleton') and the wings. Each is constructed using a mesoscale manufacturing paradigm called Smart Composite Microstructures. This entails the use of laminated laser-

micromachined materials stacked to achieve a desired compliance profile. This prototyping method is inexpensive, conceptually simple, and fast: for example, all components of the fly can be created in less than one week. Additionally, the resulting structures perform favorably when compared to alternative devices: flexure joints have almost no loss, ultra-high modulus links have higher stiffness-to-weight than any other material, and the piezoelectric actuators have similar power density to the best DC motors at any scale. After integration, the fly is fixed to guide wires that restrict the motion so that the fly can only move vertically. The wings are then driven open loop to achieve a large angular displacement. This is done at resonance to further amplify the wing motion. The wings exhibit a trajectory nearly identical to biological counterparts. Finally, this 60mg, 3cm wingspan system is allowed to freely move in the vertical direction demonstrating thrust that accelerates the fly upwards. Bench-top thrust measurements show that this robotic fly has a thrust-to-weight ratio of approximately two. These results unequivocally confirm the feasibility of insect-sized MAVs. The remaining challenges involve the development of microelectronics appropriate for power conversion, sensing, communication, and control along with the choice of an appropriate power source.

3. STRUCTURAL SYSTEMS OF FLAPPING WINGS MAV

Unlike flying machines, insects can quietly fly in all directions. They show a very useful feature: even if they hit an obstacle (e.g. a wall) they can bounce off it and continue flying and in the worst case to crawl away into safety. Therefore constructors of microaeroplanes watch the structure of insects closely. An authoritative comparative quantity is also the number of kilograms lifted by a unit of engine power. This quantity is called *power load*. For aeroplanes it is 900 W/kg, for birds over 80 W/kg, while for insects maximum 70 W/kg. It can be noted, therefore, that the use of power in Nature is more than 10 times better than in man-made flying machines (compare [4.5, 4.108, 4.110]). Because of small dimensions of MAV cargo space the distribution of necessary devices, units and on-board sensors become a very serious problem. The conception used in "large" unmanned aircrafts consisting in "filling" the inside of the airframe with necessary instruments and next their equipment – programme integration into one system in this case is practically impossible to use.

Initial aerodynamic data have been gathered and more tests, both for force measurement and flow visualization, are planned. The new data will allow a quantifiable study of the aeromechanics of insect-like flapping at the MAV scale. It will also generate information of value for the analysis of insect flight, where similar experiments are difficult to perform. Finally, the progress in understanding of the aeromechanics of insect-like flapping wings will be used to gain additional insights into the flight of real insects. Thus, an engineering study inspired by nature will contribute to a better understanding

of nature which, in turn, can be used to further progress the engineering design. This fruitful cycle seems to be a good and practical example of the real value of the interface between engineering and biology.

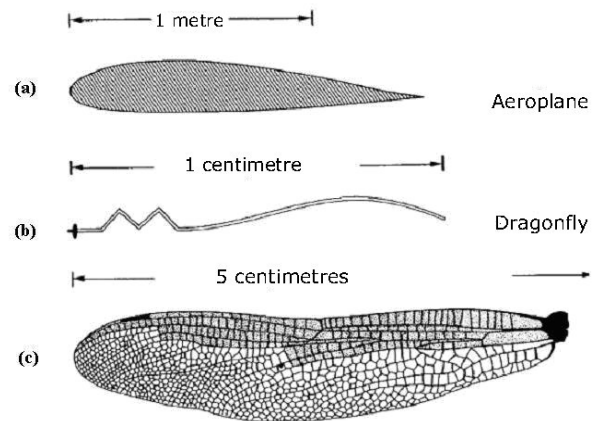

Fig. 19. Comparison of aircraft and dragonfly wing cross-section (airfoil) a) aircraft airfoil, b) dragonfly wing cross-section, c) dragonfly wing shape

Adult insects consist of three main parts: a head, a thorax, and an abdomen. The propelling system of the insect is the thorax. It consists of three segments connected by flexible joints. Three pairs of legs and one or two pairs of wings are connected to the segments. The abdomen also consists of segments. It contains the following systems: digestive, urinary, circulatory (including the heart), a large part of the respiratory system and the reproductive system. Most of the blood is situated in special chambers, creating a bath for the internal organs, and blood does not distribute oxygen, but only purifies the organism and carries fuel, hormones and nutrient media for the tissues. Air gets inside the insect through special openings and is distributed throughout the body by a system of tracheas. The flow of the air is enforced by contracting and expanding special bellows located in the abdomen, and the flow of the air is faster when the insect is flying.

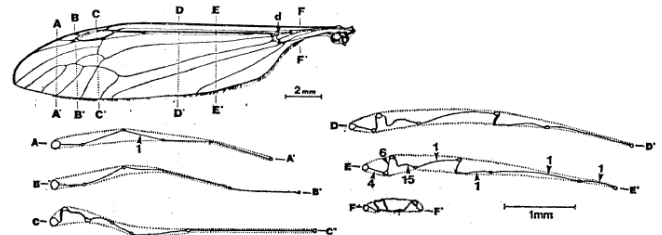

Fig. 20. Folds created on cross-section of a wing generate vortices causing, transformation of wing plate into effective airfoil

The wings of insects are of different shapes, but their structure is similar with all species. It can be stated, that wings of insects have semi-shell structure. The covering are two layers of chitin, thickness of the order of a few micrometers. This covering is enforced by spars (fibres) radiating from the shank in the hole of the body. In the state of rest the wings of an insect are flat. However during a flight they bend one way or the other and deform

(fig. 4). Insects can have two pairs of wings or one pair of wings (*diptera*). Some insects equipped with two pairs of wings can set them in motion independently (e.g. dragonflies – *lastes sponsa* – can dislocate pairs of wings during flight by 90°). However, with most species the pairs of wings work together. With some insects, such as the fly or mosquito, the second pair of wings transformed into little sticks – so called halteres, which act as a balancing system. The wings work in conditions of unsteady of flow (which has a significant influence on their aerodynamic effectiveness).

4. MEMS BASED INSECT CYBORG FLIGHT CONTROL

Insects are characterised by incredible resistance to unfavourable environmental conditions. Probably thanks to that around 750 000 species of insects survived to our times (whereas e.g. the number of species of mammals reaches only around 4 000). Compared with other animals the insects are characterised by a great diversity of shapes and ways of life, however their basic structure is the same. A lifting element of this structure is a hard and at the same time very light external chitin armour (cuticle). It serves not only as an exoskeleton being at the same time attachment place for the muscles, but also as waterproof covering protecting the intestines of the insect from dehydration.

The central computer of insects is their brain, consisting of 400 000 neurons, 98% of which is engaged in transforming information brought by the insect's sensors (e.g. eyes, ocelli, halteres, antennae). The flight control system is governed by less than 3 000 neurons. The motion of the wings is generated by around 20 different muscles. The wings are attached to the fuselage with the use of three joints. This enables performing complicated motions in relation to the fuselage (such mechanism of mounting the wings enables banking in relation to the fuselage of the resultant aerodynamic force and generating controlling forces and moments in a way similar to rotorcrafts – compare [1, 2, 25-30]. Progress in biology, and computer sciences allow to find alternative solution of flapping wings MAV design.

The paper [3] reports the first direct control of insect flight by manipulating the wing motion via microprobes and electronics introduced through the Early Metamorphosis Insertion Technology (EMIT). EMIT is a novel hybrid biology pathway for autonomous centimeter-scale robots that forms intimate electronic-tissue interfaces by placing electronics in the pupal stage of insect metamorphosis. This new technology may enable insect cyborgs by realizing a reliable control interface between inserted microsystems and insect physiology. This paper presented design rules on the flexibility of the inserted microsystem and the investigation towards tissue-microprobe biological and electrical compatibility.

In the case of flight muscle actuation, the main flight powering muscles are located in the dorsal-thorax of the *Manduca sexta* (Figure 21) where electronic implants can be located. The dorsoventral and dorsolongitudinal muscle

groups move the wings by changing the conformation of the thorax, which supplies the mechanical power for up- and downstrokes. The alternating relaxation and contraction of these muscles create the alternating up- and down-strokes hence the flight. Therefore, the designed probe should target actuating these muscle groups.

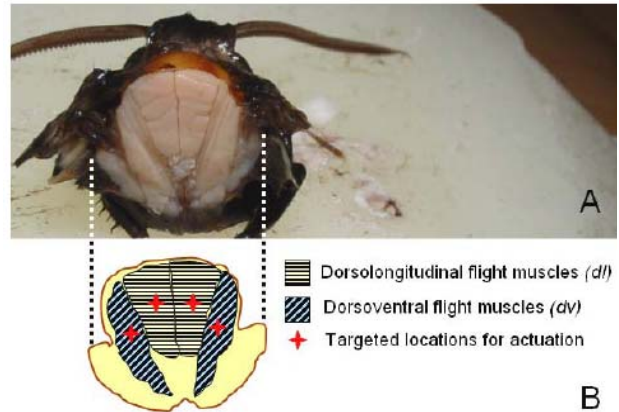

Fig.21. Cross-section (A) and illustrated diagram (B) of the flight muscles powering the up- and down-stroke of *Manduca sexta* wings (cf. [5])

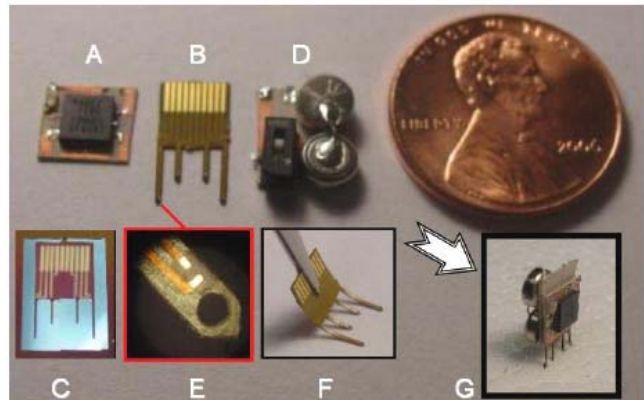

Fig. 22. The microsystem including microprocessor (A), flexible probe (B), silicon probe (C) and battery unit for power (D), the close-up view of the tip in (E) with the hole for muscle growth, the flexibility of the probe (F) and the assembled system (G) (cf. [5]).

The aimed experimental protocols consist of tethered setups where insect flight muscle is actuated through the flexible wires, as well as non-tethered setups where there are no attached wires and free-flight of insect can be realized. We designed and manufactured a flexible probe that can work with both setups (Figure 22B). The microsystem for autonomous control of the probe electronics can be seen in the same figure and consists of three parts: power, probe and control layers. The power layer (Figure 22D) is comprised of two coin batteries and a slide-switch positioned on a printed circuit board (PCB). Each battery has an energy capacity of 8mAh and weighs 120mg. Conductive adhesive was used to attach the batteries to the platform. The control layer (Figure 22A) is- an 8x8mm² PCB holding the microcontroller (Atmel Tiny13V) and an LED. The microcontroller was

electrically connected to the PCB via flip-chip bonding. Wire-bonding was used to connect the PCB to the probe layer. The microfabricated silicon probe is sandwiched between these two layers (Figure 22G). The overall system has dimensions of $8 \times 7 \text{ mm}^2$ and total mass of 500 milligrams. The flexible probe can also be used in tethered setups by utilizing a FFC/FPC connector (Figure 23). All-silicon rigid probes, which provide higher stiffness for narrower cross-section enabling higher density probing, were also fabricated and tested (Figure 22C).

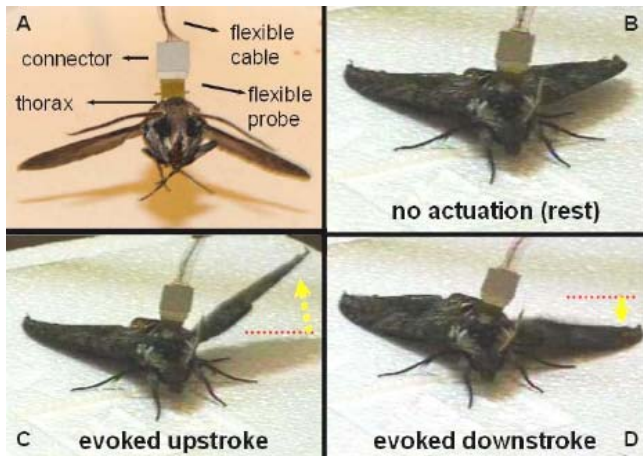

Fig. 23. The evoked up- and downstroke of a “single” wing obtained by applying 5V pulses to the indirect flight muscles (snapshots from the recorded movie). Under natural conditions, moths flap both wings together (cf. [5])

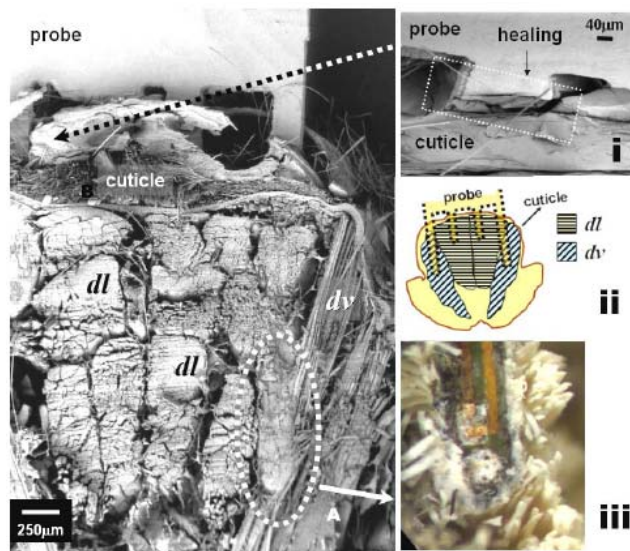

Fig. 24. The cross-section of thorax near the probe with explanatory schematic (ii) of thoracic flight muscles. Cuticle sealing (i) and muscle growth (iii) around the probe indicates integration by the body.(dl: dorsolongitudinal flight muscle, dv: dorsoventral flight muscle, see Figure 21) cf [5]

It is possible [5] to demonstrate a reliable hybrid tissue-electronics interface in insects that provides flexibility against tissue movement. Inserting the probes at an early pupal stage ensures that the tissue grows around the probes for a highly natural implant. We also showed down- and

up-stroke actuation of each wing separately, through which we were able to affect the flight direction of *Manduca sexta*. The work [5] paves the way for future engineering approaches to utilize the bioelectronic interfaces especially for realizing insect cyborgs.

5. CONCLUSIONS

It should be emphasized, that despite the extraordinary requirements posed for the systems of microaeroplanes, everything points to the fact that modern developments of microelectronics and microelectromechanics already allow constructing a fully-functional miniature aircraft. Also the contemporary knowledge in the field of aerodynamics of little Reynolds numbers (got, among others, thanks to researchers dealing with the problems of flight of birds and insects) allows designing its shape and assessing its dynamic properties. Therefore, it should be expected, that the first generation of microaeroplanes

Therefore, it should be expected, that the first generation of microaeroplanes will be supplied to military units shortly.

REFERENCES

1. **Azuma A, Masato O., Kunio Y.,** (2001), Aerodynamic characteristics of wings at low Reynolds Numbers. *Fixed and flapping wings aerodynamics for micro air vehicle applications*, Ed T, J, Mueller, Progress in Astronautics and Aeronautics, AIAA, Reston, Va., 341-398
2. **Azuma A.,** (1998), *The biokinetics of flying and swimming*, Springer Verlag, Tokyo
3. **Bolsman C. T., Bjorn P., Goosen H. F. L., Schmidt R. H. M., Keulen F. van,** The Use of Resonant Structures for Miniaturizing FMAVs, *3rd US-European Competition and Workshop on Micro Air Vehicle Systems (MAV07)*.
4. **Bergou A., J., Sheng Xu, Wang Z. J.,** (2007), Passive wing pitch reversal in insect flight, *J. Fluid Mech.*, vol. 591, 321–337
5. **Bozkurt A., Gilmour R., Stern D., Lal A.,** (2008), MEMS based bioelectronic neuromuscular interfaces for insect cyborg flight control, *MEMS 2008*, Tucson, AZ, USA, January 13-17, 160-163
6. **Doncieux S., Mouret J.-B., Muratet L., Meyer J.-A.,** (2006), The ROBUR project: towards an autonomous flapping-wing animat, *Proceedings of the 5th European MAV conference and Competition*, Braunschweig, July, 2006
7. **Dickinson M. H.,** (1999), Bionics: Biological insight into mechanical design, *Proceedings of the National Academy of Sciences*, December 7, 1999, vol. 96, no. 25, 14208–14209
8. **Dickinson M, H., Lehmann F. O., Sane S. P.,** Wing rotation and the aerodynamic basis of insect flight, *Science*, Vol. 284, 1954-1960
9. **Ellington C. P.,** (1984) The aerodynamics of hovering insects flight. III Kinematics. *Philosophical Transactions of the Royal Society of London. Series B. Biological Sciences*, 305 (1122), 41-78
10. **Ellington C. P.,** (1999), The novel aerodynamics of insect flight: applications to micro-air-vehicles, *The Journal of Experimental Biology*, 202, 3439–3448
11. **Grasmeyer J. M., Keennon M. T.,** (2001), Development of the Black Widow Micro Air Vehicle, *AIAA-2001-0127 CP*
12. **Hewish M.,** (1999), A bird in the hand, *Janes International Defense Review*, no. 11

13. **Hicks R., Rais-Rohani M.**, (1999), Multidisciplinary design and prototype development of a micro air vehicle, *J. of Aircraft*, vol. 36, no. 1, 227-234
14. **Joon-Hyuk Park, Kwang-Joon Yoon, Hoon-Cheol Park**, (2007), Development of bio-mimetic composite wing structures and experimental study on flapping characteristics, *Proceedings of the 2007 IEEE International Conference on Robotics and Biomimetics*, December 15 -18, 2007, Sanya, China, 25-30
15. **Karpelson M., Gu-Yeon Wei, Wood R. J.**, (2008), A review of actuation and power electronics options for flapping-wing robotic insects, *2008 IEEE International Conference on Robotics and Automation*, Pasadena, CA, USA, May 19-23, 2008, 779 - 786
16. **Kroo I., Kunz P.**, (2000), Development of the mesicopter: A Miniature Autonomous Rotorcraft, *Proceedings of the American Helicopter Society Vertical Lift Aircraft Design Conference*, San Francisco, CA
17. **Madejski J.**, (1991), Napędy owadzie i ptasie, Dodatek do książki: *Traktat o śmigłach*, Wyd. PAN, Warszawa
18. **Malladi B., Krashanitsa R., Silin D., Shkarayev S.**, (2007), Dynamic model and system identification procedure for autonomous ornithopter, *Proceedings of the 3rd US-European MAV conference and Competition*, Toulouse, September 2007
19. **Margerie E. de, Mouret J.-B., Doncieux S., Meyer J.-A., Ravasi T., Martinelli P., Grand C.**, (2007), Flapping-wing flight in bird-sized UAVs for the Robur project: from an evolutionary optimization to aeal flapping-wing mechanism, *Proceedings of the 3rd US-European MAV conference and Competition*, Toulouse, September 2007
20. **Marusak A., Pietrucha J., Sibilski K., Złocka M.**, (2001), Mathematical modelling of flying animals as aerial robots, *7th IEEE Inter. Conf. on Methods and Models in Automation and Robotics (MMAR 2001)*, Międzyzdroje, Poland, Aug. 28-31
21. **Maxworthy T.**, (1979), Experiments on the Weis-Fogh mechanism of lift generation by insects in hovering flight. Part I. Dynamics of the "fling", *J. Fluid Mech.*, Vol. 93, part 1, 47-63
22. **McMichael J. M., Francis M. S.**, (1997), Micro Air Vehicles - Toward a new dimension in flight, *Proceedings of the 23th Annual AUVSI Conference*
23. **Michelson R. C., Helmick D., Reece S., Amarena C.**, A reciprocating chemical muscle (RCM) for Micro Air Vehicle „Entomopter” flight, <http://avdil.gtri.gatech.edu/RCM/RCM/Entomopter/AUVSI-7/EntomopterPaper.htm>
24. **Michelson R.C.**, Micro Air Vehicle „Entomopter” Project, <http://avdil.gtri.gatech.edu/RCM/RCM/Entomopter/EntomopterProject.html>
25. **Narkiewicz J., Pietrucha J., Sibilski K.**, (2000), Can modern rotorcraft aeromechanics help to design entomopter propulsion?, *Prace Instytutu Lotnictwa*, no 163
26. **Pietrucha J., Sibilski K.**, (2003), Od stworzeń latających do miniaturowych statków powietrznych, *NIT - Nauka, Innowacje, Technika*, nr 1
27. **Pietrucha J., Poniznik Z.**, (2004), Kto jest mistrzem latania? Wykorzystanie energii w naturze, *NIT - Nauka, Innowacje, Technika*, nr 3
28. **Pietrucha J., Sibilski K., Złocka M.**, (2000), Modelling of aerodynamic forces on flapping wings – questions and results, *Proc. of 4th Inter. Seminary on RRDPAE-2000*, Warsaw
29. **Platzer M. F. et al.**, (1993), Aerodynamic analysis of flapping wing propulsion, *AIAA 93-0484CP*
30. **Pornsin-Sisirak T., et. all.**, (2000), MEMS wing technology for a battery-powered ornithopter, *13th IEEE Inter. Conf. On Micro Electro Mechanical Systems (MEMS '00)*, Miyazaki, Japan, Jan. 23-27
31. **Priyadarshi A.K., Gupta S.K., Gouker R., Krebs F., Schroeder M., and Warth S.**, (2007), Manufacturing multi-material articulated plastic products using in-mold assembly. *International Journal of Advanced Manufacturing Technology*, VOL. 32, no 3-4, 250 – 365
32. **Sane S. P.**, (2003), The aerodynamics of insect flight, *The Journal of Experimental Biology* no. 206, 4191-4208
33. **Schenato L., Deng X., Wu W.C., Sastry S.**, (2001), Virtual insect flight simulator (VIFS): A software testbed of insect flight, *IEEE International Conference on Robotics and Automation*
34. **Shyy W, Berg M., Ljungqvist D.**, (1999), Flapping and flexible wings for biological and micro air vehicles, *Progress in Aerospace Sciences*, Vol. 35, 455-505
35. **Sibilski K.**, (2004), Dynamics of flapping wings micro-air-vehicle, *Acta Polytechnica*, vol. 44, no. 2
36. **Singh B., Ramasamy M., Chopra I., Leishman J. G.**, (2004), Insect-based flapping wings for micro hovering air vehicles: experimental investigations, *Proceedings of the American Helicopter Society International Specialists Meeting on Unmanned Rotorcraft*, Arizona, January, 2004
37. **Smith M. J. C., Wilkin P. J., Williams M. H.**, (1996), The advantages of an unsteady panel method in modelling the aerodynamic forces on rigid flapping wings, *Journal of Experimental Biology*, Vol. 199, 1073-1083
38. **Sunanda S., Kawachi K., Watanabe I., and Azuma A.**, (1993), Performance of a butterfly in take-off flight, *J. of Experimental Biology*, 1993, Vol. 183, 249-277
39. **Tobalske B. W., Dial K. P.**, Flight kinematics of black-billed magpies and pigeons over a wide range of speeds, *Journal of Experimental Biology*, 1996, Vol. 199, 263-280
40. **Weis-Fogh T.**, (1973), Quick estimates of flight fitness in hovering animals including novel mechanism for lift production, *J. of Experimental Biology*, Vol. 59, 169-230
41. **Willmott A. P., Ellington C. P.**, (1997), The mechanics of flight in the hawkmoth *manduca sexta*. Part I. Kinematics of hovering and forward flight; *Journal of Experimental Biology*, 200, 2705–2722
42. **Wood R.**, (2008). Fly, Robot Fly, *IEEE Spectrum*, March 2008, 25 – 29
43. **Wood, R. J.**, (2008), The First takeoff of a biologically inspired at-scale robotic insect, *IEEE Transactions on Robotics*, Vol. 24, No. 2, 341-347
44. **Vörsmann P.**, (2003), MAV State-of-the-Art & Technology Drivers, *Proceedings of the MAV-Workshop*, Elmau, Sept. 22- 24, 2003
45. **Xinyan Deng, Schenato L, S. Shankar Sastry S. S.**, (2006), Flapping flight for biomimetic robotic insects: Part II -flight control design, *IEEE Transactions on Robotics*, Vol.. 22, No. 4, 789-803
46. **Zaem A. K., Agrawal. S. K.**, (2005), Force and moment characterization of flapping wings for micro air vehicle application, *American Control Conference*, June 8-10, Portland, OR, USA, WeC11.4
47. **Żbikowski R.**, (2003), Flapping wing MAVs. *By-invitation-only workshop on Micro Aerial Vehicles - Unmet Technological Requirements*, DLR Institut für Aeroelastik, Göttingen/Germany, Elmau Castle/Germany, September 22 – 24
48. **Żbikowski R., Galiński C.**, (2005), Insect-like flapping wing mechanism based on a double spherical Scotch yoke, *J. Royal Soc Interface*, Vol. 2, no. 3, 223–235