

## LOGIC LEVEL OF WORKPIECE OBJECT DATABASE ORIENTED ON MANUFACTURING FEATURES

**Janusz Pobożniak**

### Summary

Manufacturing features are widely accepted as a means for the integration of CAD/CAPP/CAM systems. Despite high number of works in this area, the investigations on the logic structure of the databases used for the storage and processing of manufacturing features are very limited. The paper presents the logic level of the object database oriented on manufacturing features. This level consists of four layers: topics, structures, attributes and methods. Each of these layers is discussed and illustrated with the examples taken from the workpiece modeling subsystem of rotational parts with non-rotational features.

**Keywords:** CAD/CAPP/CAM integration, manufacturing features, object database of features, manufacturing feature representation

### Poziom logiczny obiektowej bazy danych modelu przedmiotu zorientowanej na cechy technologiczne

#### Streszczenie

Cechy technologiczne to powszechnie uznawane parametry integracji systemów CAD/CAPP/CAM. Dotychczas, pomimo dużej liczby prac z tego zakresu, nie przygotowano kompleksowej struktury logicznej baz danych używanych do zapisu cech technologicznych i przetwarzania zapisanych w nich informacji. W pracy przedstawiono poziom logiczny obiektowej bazy danych zorientowanej na cechy technologiczne. Wyróżniono cztery warstwy: tematów, struktur, atrybutów i metod. Przedstawiono charakterystykę przeznaczenia tych warstw oraz podano przykłady zawarte w podsystemie modelowania przedmiotów klasy bryła obrotowa z dodatkowymi cechami nieobrotowymi.

**Słowa kluczowe:** integracja systemów CAD/CAPP/CAM, cechy technologiczne, obiektowa baza danych cech, reprezentacja cech technologicznych

## 1. Introduction

Manufacturing features (Fig. 1) are widely accepted as a means for the integration of CAD/CAPP (Computer Aided Process Planning)/CAM (Computer Aided Manufacturing) systems. A feature is the unit of information about the workpiece, containing geometric and non-geometric data, with different degree of complexity and hierarchy, used during the design, process planning or other engineering works.

---

Address: Janusz POBOŻNIAK, Ph.D. Eng., Production Engineering Institute, Cracow University of Technology, al. Jana Pawła II 37a, 31-864 Cracow, Poland, phone (48 12) 428-32-62, Fax: (48 12) 648 20 10, e-mail: pobożniak@mech.pk.edu.pl

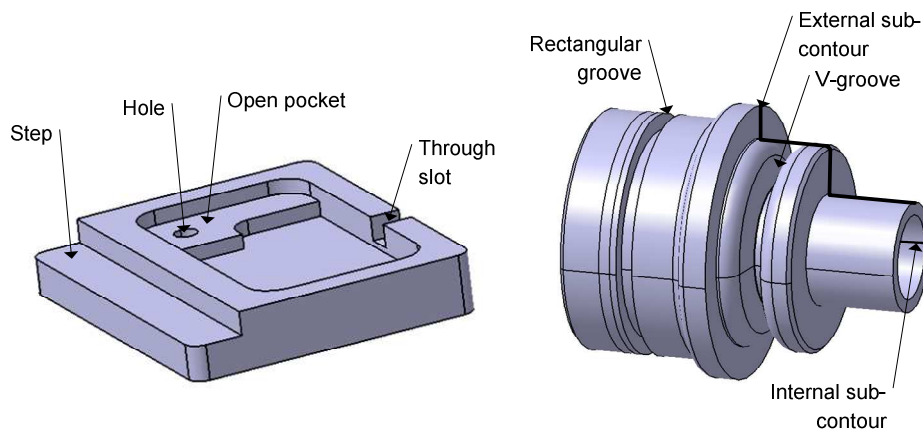

Fig. 1. Examples of manufacturing features

Manufacturing feature technology is the subject of many works, both abroad [1-3], as well as in Poland [4-12]. Especially high number of works deals with the algorithm for feature recognition. For example, the work [1] presents the exhaustive review of the manufacturing feature recognition with rule-based pattern. Despite underlining the significance of the manufacturing features in CAD/CAPP integration [6], or detailed descriptions of applications of manufacturing features in different manufacturing process planning activities [8], there is no work about the logic structure of the database used for the storage and processing of manufacturing features. Databases significantly influence the application of computer techniques. As noted in [4]: "One of the basic conditions for the successful development and implementation of the Concurrent Engineering concept is the coherence and the integration of the structural and geometric models describing the product (...). It is also the main mark of the modern production engineering, in which the product models, manufacturing process models and manufacturing resource models are integrated. These models are of course stored with the use of various CAX techniques in the electronic format." It is not possible to use the full potential of manufacturing feature technology without the appropriate organization of the manufacturing feature databases. The paper presents the logic level of the object database oriented on manufacturing features. This level consists of four layers: topics, structures, attributes and methods. Each of these layers is discussed and illustrated with the examples taken from the workpiece modeling subsystem of rotational parts with non-rotational features. The paper complements the previous works [7, 13] on the communication with the object database and the methodology of manufacturing feature recognition.

## 2. System architecture

The object-oriented database of manufacturing features is the central element of the system for part modeling in the manufacturing process planning environment (Fig. 2). The main elements of this system are as follows:

**Commercial CAD system:** The commercial CAD system SolidEdge is used for the modeling of part geometry. It is the system oriented on design feature and additionally it exposes the full B-Rep representation through the API interface. This system is also used for the modeling of some non-geometry information.

**Application for the modeling of non-geometry information:** This application runs in the commercial CAD system environment. It is intended to model the non-geometry information in a manner making possible the automatic processing of this information. It appends the blocks of non-geometric information to the basic geometric elements.

**Transformation module:** This module creates the manufacturing features-oriented part model using the geometric and non-geometric information modeled in the CAD system. The received model is stored in the object-oriented part database.

**Communication bus:** The communication bus receives the messages sent by CAx applications using the object-oriented database of manufacturing features and sends the answers to them. The messages form the process planning oriented method of information exchange. The applications using the workpiece modeling subsystem, as for example CAPP (Computer Aided Process Planning), CAAP (Computer Aided Assembly Planning) or other CAx solutions communicate with the object database of manufacturing feature through this communication bus.

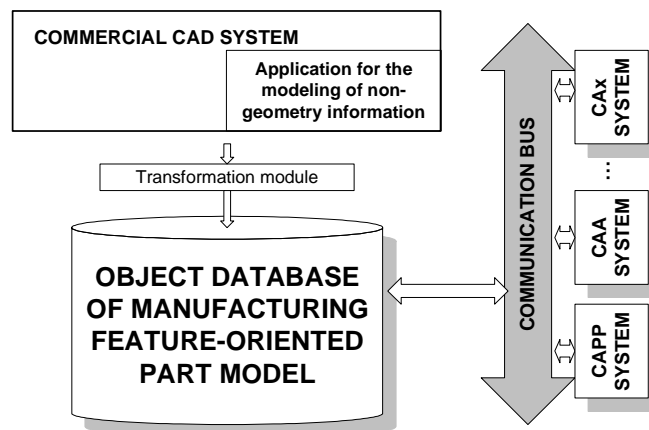

Fig. 2. Architecture of workpiece modeling subsystem

### Object database of manufacturing feature oriented part model

Database uses the workpiece model oriented on manufacturing features.

Manufacturing process planning oriented workpiece model is the set of intermediate states:

$$P = \{PO_1, PO_2, \dots PO_k\} \quad (1)$$

where:  $P$  – Manufacturing process planning oriented workpiece model,  $PO_i$  – intermediate state of the workpiece,  $I = 1 \dots k$ , for  $I = 1$  intermediate state  $PO_1$  represents the workpiece in the final state, and for  $I = k$  intermediate state  $PO_k$  represents the stock.

Each intermediate state  $PO_i$  can be described using the ordered pair:

$$PO_i = (G_i, T_i) \quad (2)$$

where:  $G_i$  – graph of the intermediate state

$$G_i = \langle C_i, W_i \rangle \quad (3)$$

where:  $C_i$  – the set of nodes representing simple and complex manufacturing features in the intermediate state  $I$ ,  $W_i$  – set of constrains in the intermediate state  $PO_i$ ,  $T_i$  – set of transformations describing the differences between two intermediate states  $P_i$  i  $P_{i-1}$

### 3. Structure of object database oriented on manufacturing features

The object database, similarly as other databases, has three levels (Fig. 3):

- **external level** (also referred to as user level or application level),
- **logic level** (also referred to as conceptual level or data model level),
- **internal level** (also referred to as physical level or storage level),

**External level** is the level used by the user (or computer system) for the communication with the database. It isolates the user from the technical details of the solution implementation in the particular system, offering high level language for the definition and access to the database. The communication is implemented through messages which can be divided into queries, data modification command and intermediate state management commands [7]. The structure of messages is similar to the very popular database language SQL. For example, the following, simple message of query type (Fig. 4):

Select ID, L, D, Ra, IT from CWO2\_OP

returns the list containing ID (identifier), L (length), D (diameter), Ra (surface roughness Ra) and IT (tolerance class) for the feature representing non-axial holes (CWO2\_OP).

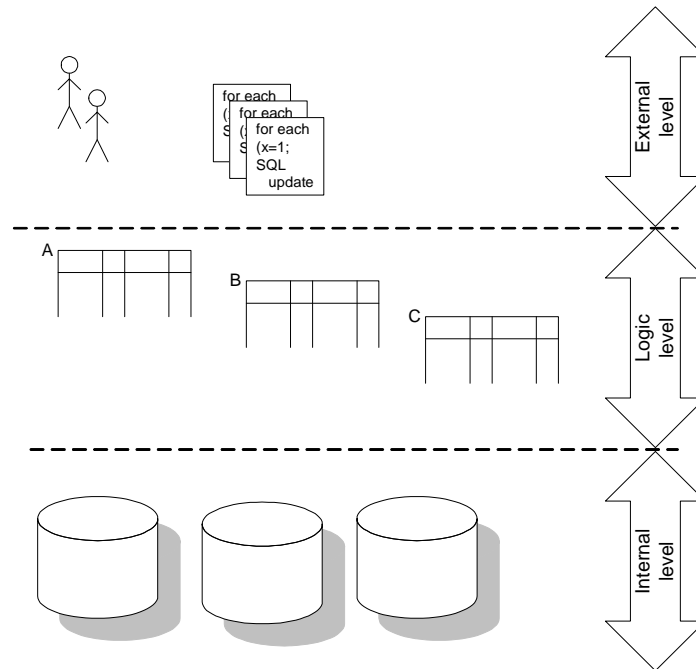

Fig. 3. Levels of database

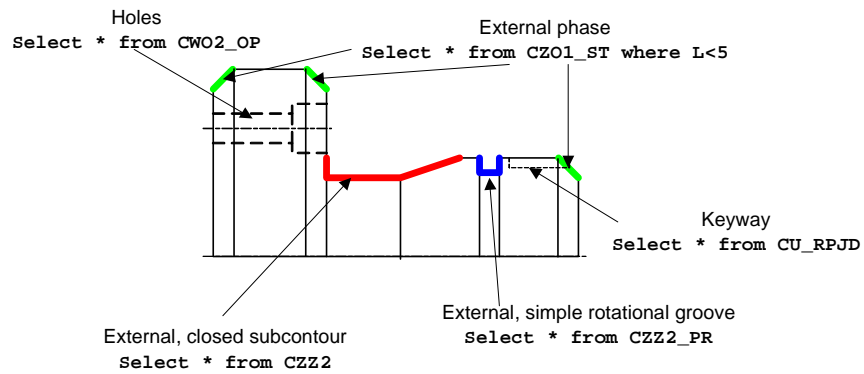

Fig. 4. Example of Select message

**Internal level** of database system is responsible for the reliable storage of physical data. This level covers different external memories, the methods of data organizations in these memories as well as techniques for the effective data management. The way of implementation of this level depends on the type of operation system.

## 4. Logic level

### 4.1. Basic definitions of object modeling

The schema of logic database is defined on the logic level. The schema of database is defined using the selected data model. In this work, the object data model was chosen, in which database consists of the set of classes, representing the objects.

**Objects** are the physical or logical (abstract) elements understood at the complete, hermetic and unique structures containing data (attributes) and behavior (methods) in the given problem area. To communicate, the method of the object is called. The calling identifies the method, can specify the parameters of the call and can return the result of calling.

The group of objects can have common data format definition. In such case, each object from this group is the example of the common definition, and the group is called as **object class**. It should be noted, that despite the common data format of objects (definition), their states can be different (each object has own state memory). Generally, the objects can share both methods as well as states. This is so called inheritance, which means that newly created objects share the data format and services defined in the other class (so the class inherits the definition of other class and extends it by new elements). The concept of class allows to distinguish the group of objects which are "similar" according to some criteria.

The basic elements of the logic level of object database are:

- topic layer,
- structure layer,
- attribute layer,
- method layer.

### 4.2. Topic layer

Because the number of objects in the project is usually very high, the object can be grouped into the **topics**. The topic is the group of related objects. Topics can be treated as the submodels or even subsystems.

To decrease the complexity of object database, three topics were distinguished:

- FEATURES,
- CONSTRAINTS,
- MANAGEMENT.

FEATURES topic covers the objects representing the manufacturing features. CONSTRAINTS topic represents the objects representing constraints between features, and MANAGEMENT topic groups represents the object used for the modeling of intermediate states and transformations.

### 4.3. Structure layer

The *entirety-part (decomposition)* and *generalization – specialization (specialization)* relations can be found between the objects creating the structure layer. *Decomposition* represents the relations between the entirety and its elements. It can be many-to-many relations between the object classes. In the graphical notation, the line representing the relation is finished with black circle, and the digits near the ends describes the numerousness of the relation (Fig. 5a). For example, the object Entirety (Fig. 5a) must be always composed of the 1 object of type Part A and none (0), 1 or 2 objects of type Part B.

*Specialization* means that "A is of type B". It allows to model the similarity between classes. Specialization occurs between particular class (*parent class*) and its specialization (*child class*). In graphical notation, specialization is marked with semicircle, and parent class is placed above the child class, which is under the semicircle (Fig. 5b).

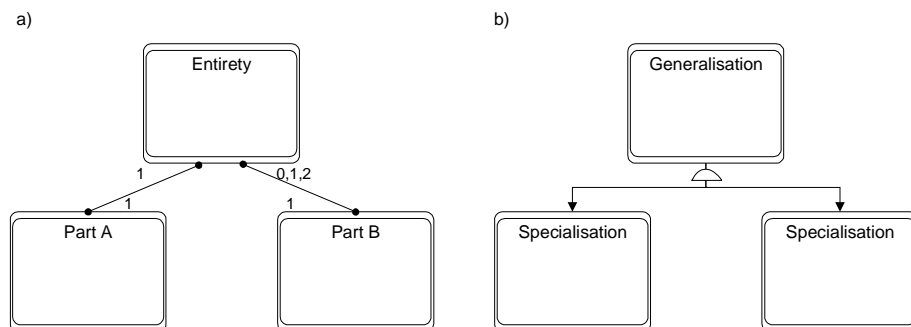

Fig. 5. Graphical representation of the relations decomposition (a) and specialization (b)

To illustrate, the structure layer of FEATURES topic for rotational part with additional, non-rotational features is presented. The manufacturing features were found using the hierarchical classification tree of machining allowances, describing the geometric shape of the manufacturing features, location of machining allowance in relation to the workpiece body, the type of contour

limiting the machining allowance on the contour side (one element or many element contour), the variation in the allowance thickness along the selected axis and the shape of the workpiece features after the removal of allowances.

Based on the analysis of this classification tree, the structure layer for the FEATURES topic was prepared (Fig. 6).

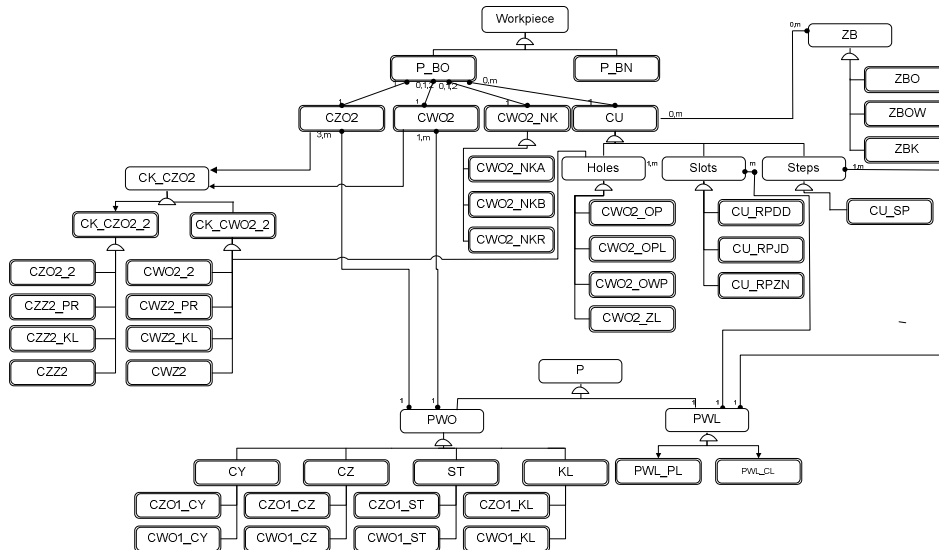

Fig. 6. Structure layer for FEATURES topic (abbreviations described in the text)

WORKPIECE class contains the basic data about the workpiece. In computer aided process planning systems, the workpieces are divided into the several groups based on the manufacturing process similarity. This classification is also reflected in the object database. The shape of the main workpiece body was selected as criterion and thus, the rotational workpieces (P\_BO) and prismatic workpieces (P\_BN) were distinguished.

P\_BO class is connected to the CZO2, CWO2, CWO2\_NK and CU classes, representing appropriately external contour, internal contour, center holes and complementary features. CZO2 and CWO2 classes describe the main body of the workpiece. According to the structure presented on the figure, each workpiece must have one external contour and can have none, one or two internal contours. It should be noted that contours are represented as the ordered series of surfaces. From the manufacturing process planning point of view, usually some sub-contours are separated as for example phases, closed contours, decreasing contours, grooves, etc. Nevertheless, such sub-contours are recognized during the manufacturing process planning [10], at so called manufacturing feature refinement phase. Such possibility is marked on the figure



by message links between CZO2 object (external contour)/ CWO2 (internal contour) and the CK\_CZO2 object representing refined features. These message links represent the fact that refined features do not have the static location in the object database. Of course, there are other message links in the database, not presented in the figure.

Refined features (CK\_CZO2 class) are divided with the specialization relation into the refined features of the external contour (CK\_CZO2) and the refined features of the internal contour (CK\_CWO2). Further classification with the specialization relation of the refined features of external contour leads to the separation of the external sub-contour (CZO2\_2), rectangular groove (CZZ2\_PR), round groove (CZZ2\_KL) and the external pocket (CZZ2). Similarly, refined features are also present in the internal contour, which can also have holes, as marked on the figure by appropriate relations.

Supplementary features are the features not creating the main body of the workpiece. Using the specialization links, the following supplementary features were found in the class P\_BO: holes, slots and steps. The holes were classified as through holes (CWO2\_OP), flat bottom holes (CWO2\_OPL), drilled holes (CWO2\_OWP) and complex holes (CWO2\_ZL), not covered by this classification and processed by the feature refinement function. Hole must have one or more (m) surfaces. Slots were divided into the through slots (CU\_RPDD), open slots (CU\_RPJD) and complex slots (CU\_RPZN), not covered by this classification. Each slot can have m surfaces. For the Step object, only steps parallel to the axis (CU\_SP) was separated. Each slot have 1 or m surfaces.

The presented classification of supplementary features is not complete. Further analysis will result in the additional supplementary features.

Supplementary features can create the sets of regularly arranged elements, represented by ZB class. The elements placed regularly on circle (ZBO), on concentric circles (ZBOW) and grate (ZBK) were separated. The links illustrate such sets of regularly arranged elements that can occur or not in the workpiece. Additionally, single feature can belong to more than one set of regularly arranged elements.

According to the schema presented in the figure, the basic elements of the external contour, internal contour or supplementary features are surfaces represented by P class. Using the specialization links, the surfaces are classified into the surfaces of rotational extrusion (PWO – surfaces of rotational extrusion) and surfaces of linear extrusion (PWL – surfaces of linear extrusion). This classification was made because the database has simplified the representation of surfaces, in contrast to the CAD database, which has the full representation. The surface of the rotational extrusion has different parameters than the surface of linear extrusion.

Similar structure layers were prepared for the CONSTRAINTS and MANAGEMENT topics.

#### 4.4. Attribute layer

Attribute layer defines the format of the object data. The object can process only its own data.

The attributes reflect the hierarchy between objects. The attributes of the object on the top of object tree, representing workpiece store the basic information about the workpiece such as the weight, batch size and the material. The object on the lower levels have the attributes related not the whole workpiece, but to the particular features. The classes on the lowest level represent the surfaces. The attributes of these classes characterize the surfaces.

To illustrate, the attributes for the object representing the external, closed contour are given (Fig. 7).

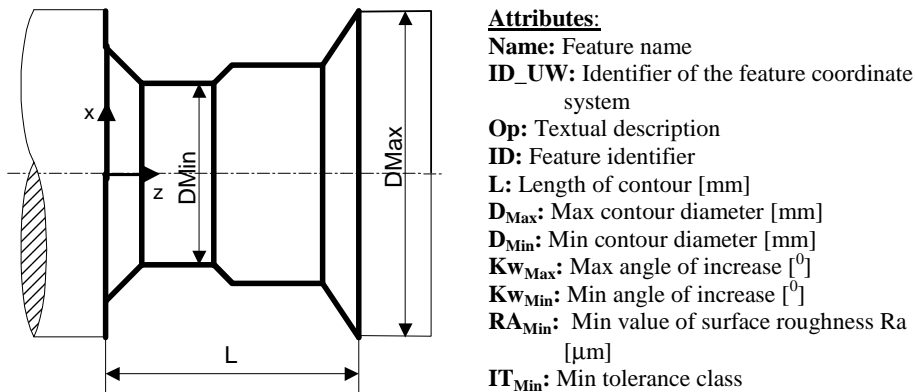

Fig. 7. Attributes for the feature representing external, closed sub-contour (CZZ2)

Similarly, the attributes for CONSTRAINTS and MANAGEMENT topics were prepared.

#### 4.5. Method layer

Method layer describes the *dynamic* relations between objects, used by the objects to react on the events, by sending appropriate messages and calling object methods. Each event must be recognized by the database object, which then calls appropriate methods, accordingly to the type of events. The method layer is responsible for calling the methods of particular objects, appropriately to the command sent on the external level of the database.

Figure 8 presents the scheme of message processing. The processing starts after the message is read from the communication bus. After the reception, the message is transformed into the multi-variant record. This record stores the name of the message and its parameters. The message record is then sent to the

method of the object on the top of the object structure, which is responsible for the message handling. If the message was not processed by the handling method of this object, it is sent to the other object. Similarly, if the message was not processed by this object, it is sent to the next object in propagation sequence. Such processing is continued until the message is processed. If the message was distributed to all objects and it was not processed, the error is generated because the message is unknown or not handled properly.

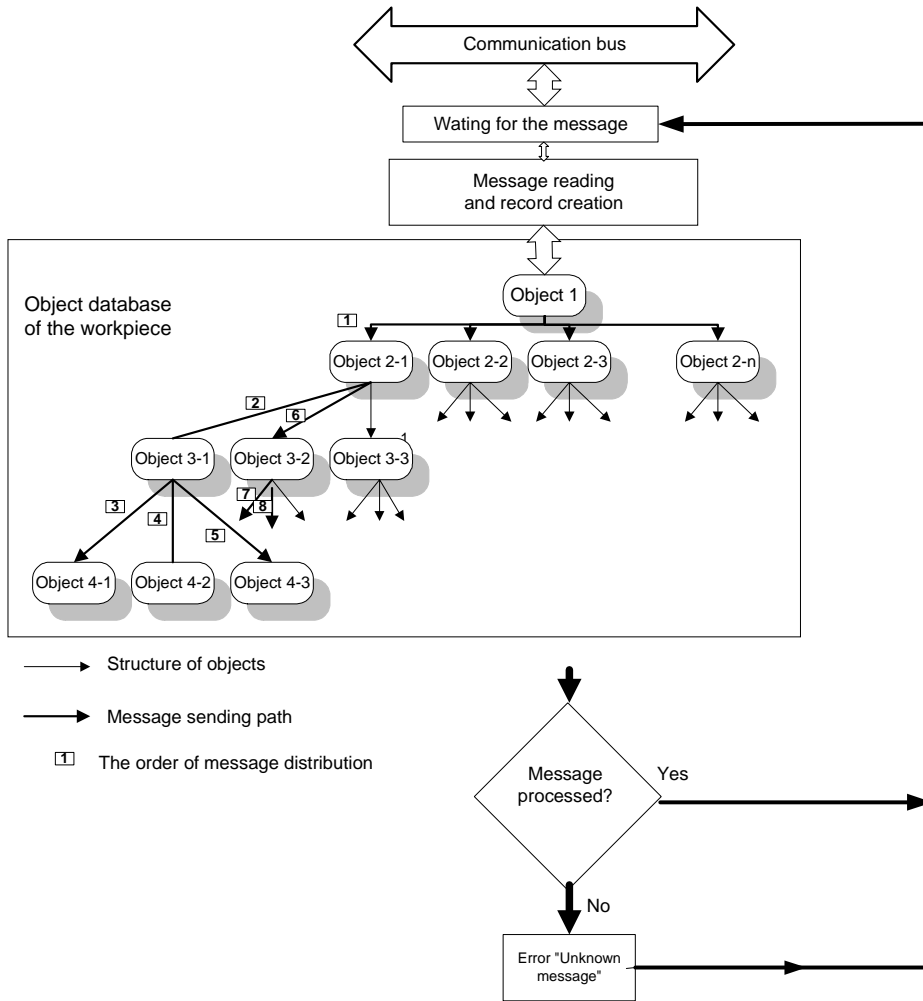

Fig. 8. Scheme of message processing

## 5. Conclusions

The paper presents the architecture of workpiece modeling subsystem. Object database of manufacturing feature oriented part model is the central element of this subsystem. The following conclusions can be drawn based on the results of the works:

- the workpiece model oriented on the manufacturing features allows to describe the workpiece using the unit of information meaningful from the manufacturing process planning point of view,
- representation of the workpiece on the logic level of the database in the form of simple and complex manufacturing features gives the access to the information on the different level of workpiece logic structure,
- the division of the logic level of the database into topics, structure, attribute and method layers decomposes to complex workpiece modeling task into the simpler basic tasks,
- representation of the features in the object database and the mechanism of communication between objects allows for the decentralized handling of messages for the data retrieval and processing, and additionally simplifies the modification and further development of database,
- the developed architecture of the workpiece modeling subsystem, in which the object database oriented on manufacturing features is the central element, can be used by different CAX systems, including CAPP (Computer Aided Process Planning) system and CAAP (Computer Aided Assembly Planning) systems.

The developed subsystem was successfully tested in the developed CAPP system [3].

## References

- [1] B. BABIC, N. NESIC, Z. MILJKOVIC: A review of automated feature recognition with rule-based pattern recognition. *Computers in Industry*, **59**(2008)4.
- [2] A.S.M. HOQUE, T. SZECSI: Designing using manufacturing feature library, *Journal of Materials Processing Technology*, **201**(2008)1.
- [3] YUSRI YUSOF, KEITH CASE: Design of a STEP compliant system for turning operations. *Robotics and Computer-Integrated Manufacturing*, **26**(2010)6.
- [4] E. CHLEBUS: Techniki komputerowe CAX w inżynierii produkcji. Wydawnictwa Naukowo-Techniczne, Warszawa 2000.
- [5] Z. MONICA, R. KNOSALA: Zastosowanie metody obiektów elementarnych w technicznym przygotowaniu produkcji korpusów. Mat. XII Konferencja "Metody i środki projektowania wspomaganego komputerowo", Warszawa 1999.
- [6] G. NIKIEL: Computer-aided CNC programming for the machining of non-typical parts. *Advances in Manufacturing Science and Technology*, **31**(2007)4.

- [7] J. POBOŻNIAK: Manufacturing oriented language for communication with part database. New materials and iT technologies in Production Engineering, Politechnika Lubelska 2011.
- [8] R. STRYCZEK: A hybrid approach for manufacturability analysis. *Advances in Manufacturing Science and Technology*, **35**(2011)3.
- [9] R. STRYCZEK: Petri net-based knowledge acquisition framework for CAPP, *Advances In Manufacturing Science And Technology*, **32**(2008)2.
- [10] J. DUDA, J. POBOŻNIAK: Projektowanie procesów i systemów wytwarzania w środowisku PLM DELMIA. *Mechanik* **83**(2010).
- [11] J. GÓRSKI: Inżynieria oprogramowania, Mikom, Warszawa 2000.
- [12] C. GRABOWIK, K. KALINOWSKI, Z. MONIKA: Integration of CAD/CAPP/ /PPC systems. *Journal of Material Processing Technology*, **164-165**(2005).
- [13] J. POBOŻNIAK: Two stage method of manufacturing feature recognition. Proc. Inter. Conf. Flexible Manufacturing and Intelligent Systems, FAIM 2008, Skovde 2008.

*Received in October 2011*