

ANALYSIS OF THE ROTATION AND LIFTING OF A MOTORCYCLE FOLLOWING AN IMPACT AGAINST A MOTOR CAR SIDE

LEON PROCHOWSKI¹, TOMASZ PUSTY²

Military University of Technology, Automotive Industry Institute

Summary

An analysis of the course of a road accident where a motorcycle hit the side of a passenger car has been presented. The scope of the analysis was limited to the post-impact motorcycle movement at the initial stage of contact with the car. At this stage, the most important forms of this movement include rotation of the motorcycle around a variably located instantaneous centre and lifting of the rear end of the motorcycle. Based on an analysis (frame-by-frame) of the video record of the experiment and the acceleration values measured on the motorcycle frame, the parameters of motorcycle motion were determined for specific time instants. The trajectories of noteworthy motorcycle points after the motorcycle impact against the car have been shown.

The parameters of motorcycle motion as determined from the experiment may provide a good basis for the road accident reconstruction process and for the analysis of the course of generation of injuries to motorcyclist's body. The course of the process of motorcycle rotation and lifting has crucial influence on the movement of motorcyclist's body and especially on the point of impact of motorcyclist's head against the car. The location of this point (side window, roof edge, roof panel) is critical for the type of the head injuries resulting from the accident.

Keywords: road accidents, motorcyclist's safety, motorcycle dynamics, impact energy

1. Introduction

Collisions between motorcycles and passenger cars are part of the group of common road accidents. The analysis of the course of road accidents where motorcyclists were involved constitutes a difficult problem, especially when the sources of generation of the most severe vehicle deformations and injuries suffered by participants in the traffic are to be determined.

¹ Military University of Technology, Faculty of Mechanical Engineering, 2 Gen. S. Kaliskiego Street, 00-908 Warsaw, e-mail: lprochowski@wat.edu.pl, ph.: +48 22 683 78 66

² Automotive Industry Institute, Vehicle Testing Laboratory, 55 Jagiellońska Street, 03-301 Warsaw, e-mail: t.pusty@pimot.org.pl, ph.: +48 22 777 70 84

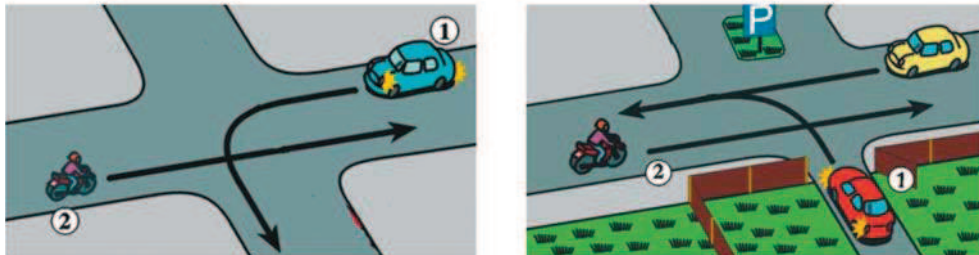

Fig. 1.1. The arising of dangerous traffic situations [7]

Dangerous situations occur e.g. when the car driver, having failed to notice a quickly moving motorcycle, enters the motorcycle path. Such situations have been illustrated in Fig. 1.1 and they usually result in an impact of the motorcycle against the car side.

This study was undertaken to analyse the rotational and lifting motion of a motorcycle having hit a motor car side. Results of this analysis may be used at the process of determining the sources of injuries suffered by motorcyclists and the balance of the energy of impact of a motorcycle against a motor car. An important area where results of this work may be useful is the reconstruction of road accidents. The analysis presented is based on results of the video recording and measurements carried out during the research experiment.

Attention was focused on an analysis of the course of the dynamic processes that have an impact on the effects of the road accident under consideration, including the trajectory of the motorcycle having hit a motor car side. The analysis covered the initial phase of the process of a motorcycle impact against a motor car side and the motorcycle motion around the instantaneous centre of rotation, the location of which changes during the collision. The motorcycle rotation during the collision directly affects the generation of the injuries suffered by the motorcyclist because it determines the car area that is hit by the motorcyclist. An issue of critical importance is the location of the point of impact of motorcyclist's head against the car side.

The problems related to the impact of a motorcycle against a motor car side have been interestingly presented in publications [3, 4]. The works described there have provided good foundations for analysing the kinematics of motion of motorcycle rider and passenger's bodies after their motorcycle hits a motor car side and this was made use of in [10]. Publications [1, 4, 6, 9] present examples of results of experimental tests and computer simulations concerning the course of the process of an impact of a motorcycle against a motor car. However, no attempts were made within those works to explain important aspects of the initial phase of the movement of a motorcycle having hit a motor car side, i.e. of the rotation of the motorcycle around the instantaneous centre the location of which changed with the motorcycle deformation process.

2. Research experiment and test specimens

At the Automotive Industry Institute (PIMOT) in Warsaw, a research experiment was carried out where a motorcycle moving with a speed of $v = 49.5$ km/h hit the side of a motor car being at a standstill. The motorcycle hit the front door of the car, close to pillar B. The experiment was prepared in cooperation with the Student Scientific Circle of Vehicle Mechanical Engineers at the Faculty of Automotive and Construction Machinery Engineering of the Warsaw University of Technology; the experiment was organised by Mr J. Seńko, D. Eng. [e-mail: jsenko@simr.pw.edu.pl].

The noteworthy stages of the experiment have been brought together in Table 2.1. The analysis described in a subsequent part of this paper made it possible to identify the main phases of motorcycle movement (including the lifting and rotation processes) and to determine motorcycle positions at specific time instants.

Table 2.1. The most important stages of the process of a motorcycle impact against a motor car side









Time	Description	Photograph
0 ms	Beginning of the sequence of a motorcycle impact against the motor car side.	
20 ms	The motorcycle begins to rotate around the centre of the area of contact of its front wheel with the car. The suspension springs begin to expand and the motorcycle lifting height does not extend 0.01 m.	
50 ms	The rear motorcycle wheel begins to be lifted (when the suspension springs are fully expanded).	

Table 2.1. cont.

Time	Description	Photograph
100 ms	Rotation of the motorcycle around the centre of the area of contact between the motorcycle frame head tube and the motor car side.	
130 ms	The front wheel of the motorcycle begins to be lifted.	
350 ÷ 360 ms	Motorcycle lifted to the maximum height.	
640 ms	The front wheel of the motorcycle hits the ground.	
700 ms	The motorcycle seat leans against the edge of the car roof.	

3. Analysis of the motorcycle movement relative to the car and the ground

The post-impact motorcycle movement chiefly depends on the height of the centre of mass of the motorcycle and motorcyclist. It also depends on the course of the car deformation and displacement process and on the influence of motorcyclist's body. Obviously, the whole process largely depends on the motorcycle speed when hitting the car. Table 2.1 shows noteworthy changes in the position of the motorcycle, motorcyclist, and car, thus indicating the nature of the motorcycle movement under consideration. The movement of motorcyclist's body is close to the movement of a free solid [10] and the possible interactions in the points of contact between the body and the motorcycle will be described in a separate paper.

Based on a video record of the experiment, taken at a rate of 1 000 fps, individual frames recorded at 10 ms time intervals were separated. Drawings made on these grounds have been presented in Table 3.1; they provided a basis for defining the changes in the motorcycle position that took place along with the progress in the motorcycle deformation process.

The drawings brought together in Table 3.1 represent successive positions of the motorcycle outline from the time instant of 0 ms (when the motorcycle wheel came into contact with the car) on. The scale of the objects has been chosen on the grounds of the known distances between individual markers placed on the motorcycle and a dimensional reference grid filmed as a stationary background. A fragment of the motor car contour has also been marked in the drawings. Authors' reference lines have been introduced as well, shown as dashed grid lines spaced at 0.5 m intervals.

Table 3.1. Motorcycle outline and a fragment of the car contour at the initial impact stage (a - shows the fragment of the car contour at the time instant of $t = 0$ ms)

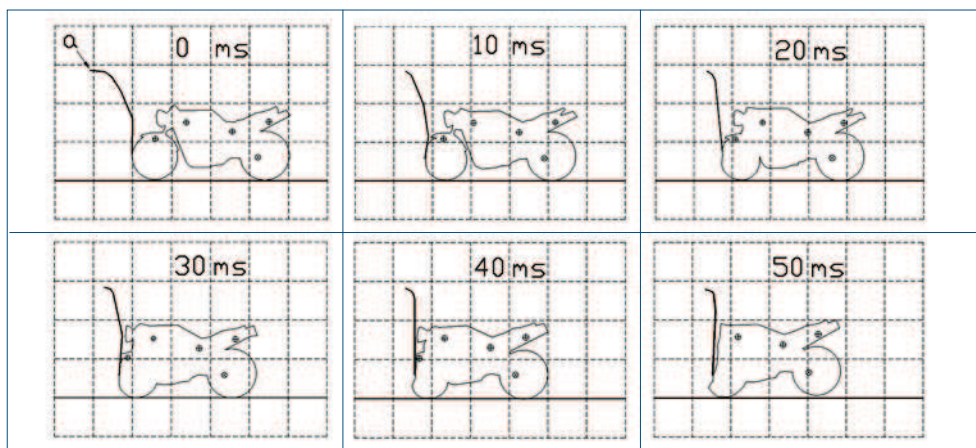
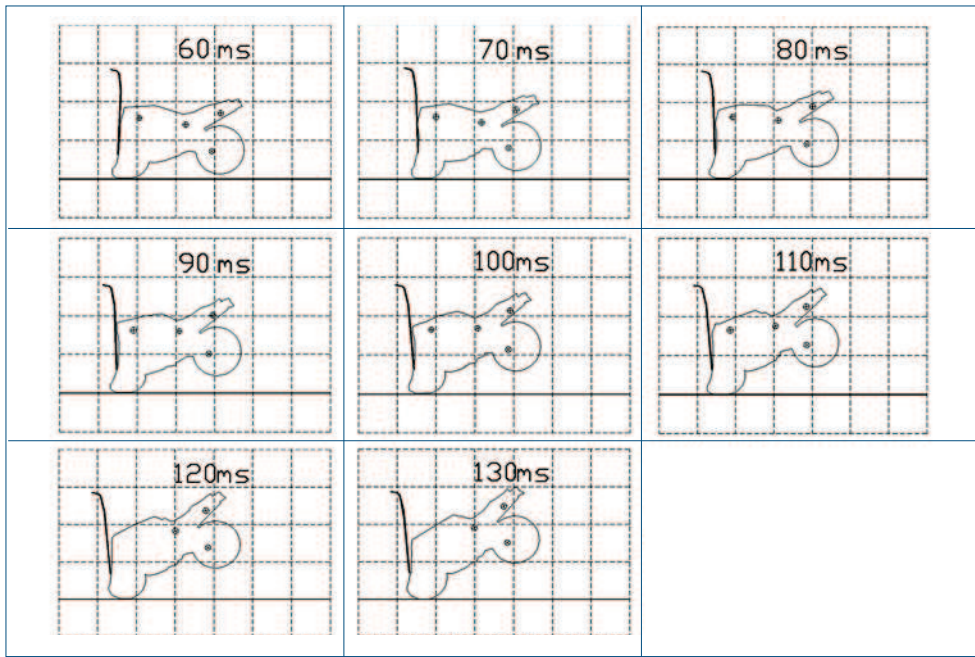

Table 3.1. cont.



The range of the motorcycle movement as shown in Table 3.1 does not cover the whole experiment range having been described. However, it is sufficient for the problems tackled in this study to be analysed. Virtually, the whole range of motorcycle displacements has been illustrated in Fig. 3.1. The drawing shows the position of markers (placed on the motorcycle) at successive time instants from 0 to 700 ms, at 20 ms time intervals. Thanks to this, the trajectories of specific motorcycle points during the experiment could be plotted.

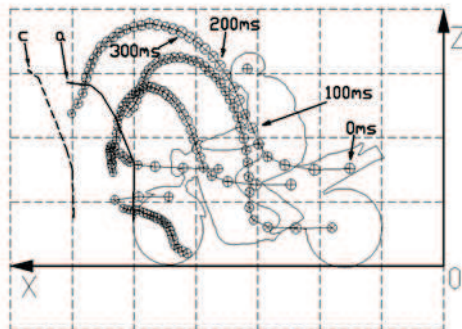

Fig. 3.1. Positions of noteworthy motorcycle points (markers) at successive time instants
(a - fragment of the car contour at $t = 0$ ms; c - fragment of the car contour at $t = 380$ ms)

It can be seen from the drawings in Table 3.1 and from the shapes of the trajectories shown in Fig. 3.1 that in the time interval from 50 ms, the motorcycle movement may be described as translation during which the front motorcycle part is crushed. The motorcycle rotation and the lifting of its rear wheel become well visible when a time of about 50 ms elapses from the beginning of the impact process (from the moment when the suspension springs are fully expanded).

4. The process of rotation and lifting of the motorcycle

From the beginning of contact of the front motorcycle wheel with the car, a reaction force appears in the zone of deformation of the vehicles; the reaction force has been symbolically represented by its components R_s and R_N . This reaction together with the forces of inertia applied to the centre of mass of the motorcycle (F_{Bx} and F_{Bz}) and the motorcyclist (F_{Kx} and F_{Kz}) constitute the basic force system changing with the progress in the deformation process. The action of this force system results in rotational motion of the motorcycle and lifting of the rear motorcycle wheel, after 20 ms (Fig. 4.1).

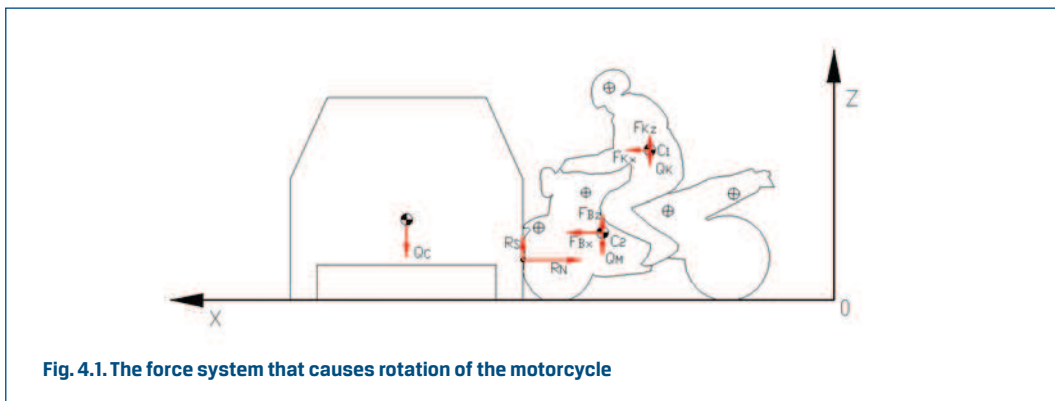

Fig. 4.1. The force system that causes rotation of the motorcycle

In the time interval from 20 to 100 ms, the process of rider's movement along the motorcycle seat. During this movement, friction forces are exerted by motorcyclist's body on the seat and rider's thighs strongly act on the fuel tank of the motorcycle. The action of these forces considerably affects the motorcycle rotation, with increasing height of the instantaneous rotation centre. Simultaneously, progress in the motorcycle deformation process and the resulting growth in the area of contact between the motorcycle and the car foster a rise in the height of the motorcycle rotation centre, which has been illustrated in Fig. 4.2. For the initial period of up to about 100 ms, the instantaneous motorcycle rotation centre moves from point h_1 to point h_2 (Fig. 4.2). Point h_1 is the centre of the area of contact between the deformed front motorcycle wheel and the car. The position of the instantaneous motorcycle rotation centre changes until the rotation angle in the vertical plane reaches about 15° . In this motorcycle position (Fig. 4.2), the main component of the car reaction force acts on the motorcycle frame head tube, which leans against the car at point h_2 .

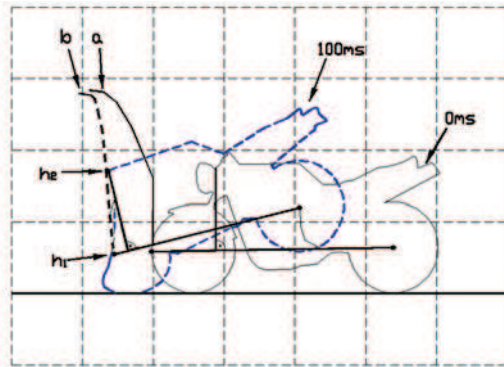

Fig. 4.2. Change in the position of the instantaneous motorcycle rotation centre
(a - fragment of the car contour at $t = 0$ ms; b - fragment of the car contour at $t = 100$ ms)

Based on the experiment carried out, Fig. 4.3 has been drawn where changes in the motorcycle rotation angle at specific time instants have been shown. In this drawing, the motorcycle rotation angle has been defined as the angle between the line segment connecting the centres of rotation of motorcycle wheels and the OX axis.

The time history of the motorcycle rotation angle has been shown in Fig. 4.4, where a curve representing changes in the height of lifting of the axis of rotation of the rear motorcycle wheel has been plotted as well. The lifting, denoted by U in Fig. 4.3, is related to the complex motorcycle movement, which includes the following at this stage:

- Translation in the OX direction;
- Shortening of the wheelbase (motorcycle deformation);
- Rotation around a variably located instantaneous rotation centre.

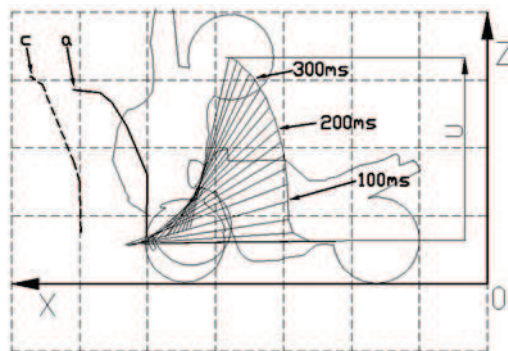

Fig. 4.3. Motorcycle lifting process
(a - fragment of the car contour at $t = 0$ ms; c - fragment of the car contour at $t = 380$ ms)

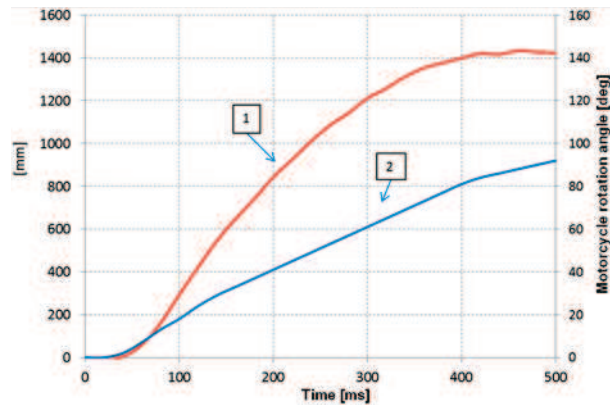

Fig. 4.4. Motorcycle rotation angle and lifting of the rear motorcycle wheel
(1 - rear wheel lifting height U ; 2 - motorcycle rotation angle φ)

The curves shown in Figs. 4.3 and 4.4 describe the general motorcycle movement, virtually covering the whole deformation phase, and the motorcycle rotation, the angle of which is close to 90° when the rear wheel is lifted to its maximum height.

The curves plotted in Fig. 4.5 have a different nature. They represent the vertical displacement, denoted by z_c , and the vertical component (V_{cz}) of the velocity vector of the centre of motorcycle mass. Based on the time history of the displacement, discrete values of the vertical component of the velocity vector of the centre of motorcycle mass were determined from the following formula:

$$V_{cz}(t) = \frac{\Delta z_c(t)}{\Delta t} \quad (1)$$

where:

$z_c(t)$ - vertical displacement of the centre of motorcycle mass, determined from a frame-by-frame analysis.

Like the quantity U in Fig. 4.4, the curves analysed here depend on the complex nature of the movement and deformation of the motorcycle. The impact of a considerable number of factors affects also the accuracy of determination of the values calculated. The accuracy of calculations was estimated on the grounds of [8] and it has been presented in the form of vertical line segments showing the uncertainty intervals of the values calculated.

The calculation results presented in Fig. 4.5 will be used to determine some components of the energy dissipated during the process of a motorcycle impact against the motor car side.

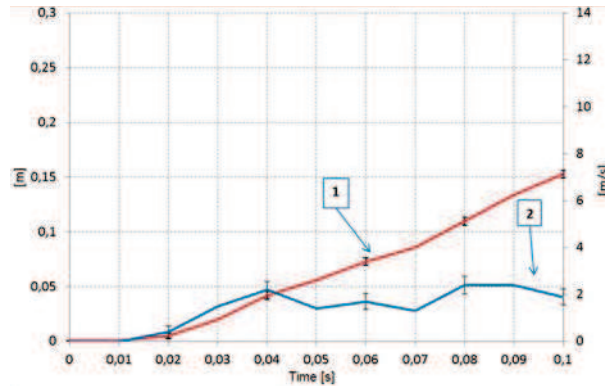

Fig. 4.5. Time histories of values of the vertical displacement and the vertical component of the velocity vector of the centre of motorcycle mass (1 - z_c , 2 - V_{cz})

5. Analysis of the kinematics of the motorcycle movement, based on results of acceleration measurements

The possibility was considered whether and how the acceleration measurement results obtained for one of the marked motorcycle points might be used as a supplement to improve the accuracy of calculations of time histories of the displacement and velocity of the centre of motorcycle mass.

An acceleration sensor, whose location has been shown in Fig. 5.1 (denoted by M), was used to record components of the acceleration signal in three mutually perpendicular directions $a_{Mx'}$, $a_{My'}$, and $a_{Mz'}$. The measured time histories of accelerations a_{Mx} and a_{Mz} were used to determine the acceleration component parallel to the OZ axis, i.e. a_{MZ} (Fig. 5.1). The component a_{MZ} in the global reference system was calculated with taking into account the previously determined time history of the angle φ of rotation of the motorcycle together with the sensor (Figs. 4.4 and 5.1):

$$a_{MZ}(t) = -a_{Mx}(t) \sin \varphi(t) + a_{Mz}(t) \cos \varphi(t) \quad (2)$$

The calculation results have been shown in Fig. 5.2.

5.1. Relating of the acceleration measurement results to the centre of motorcycle mass

To facilitate the determining of the quantities necessary for the calculation of impact energydissipation, the measurement results were related to the centre of motorcycle mass. This was done with taking as a basis a diagram shown in Fig. 5.3, where an assumption was made that the motorcycle frame was perfectly rigid, i.e. that the position of points C and M in relation to each other remained unchanged during the movement phase being analysed.

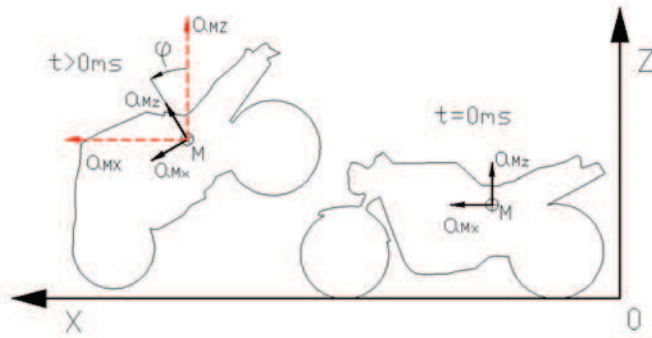

Fig. 5.1. Directions of the accelerometer measurement axes a_{Mx} and a_{Mz}

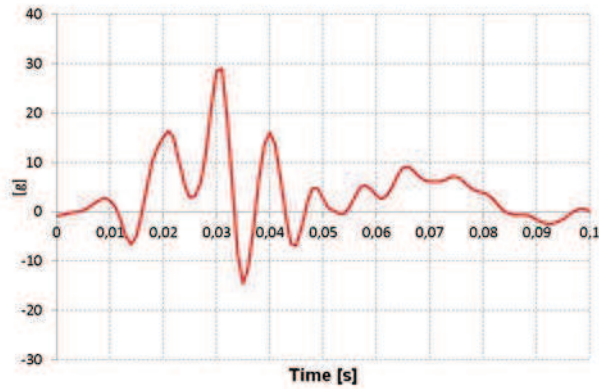

Fig. 5.2. The a_{Mz} vs. time curve

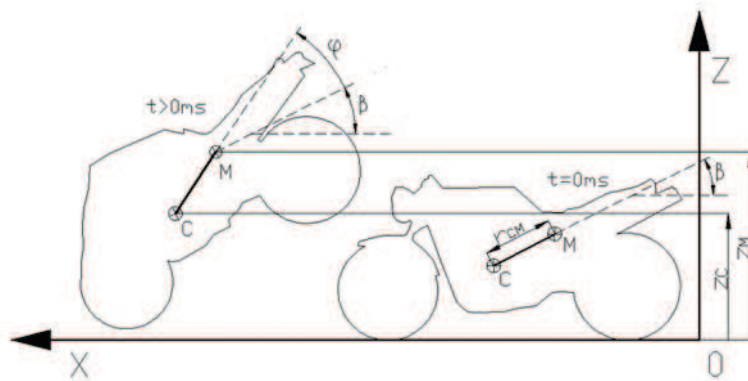

Fig. 5.3. Schematic diagram adopted for calculations of the acceleration of the centre of motorcycle mass

Legend:

r_{CM} - distance between points C and M on the motorcycle

β - original value of the angle between the CM line and the OX axis

$\varphi(t)$ - motorcycle rotation angle as a function of time

Based on Fig. 5.3, the interrelation between displacements of points M and C has been determined:

$$z_C(t) = z_M(t) - r_{CM} \sin(\beta + \varphi(t)) \quad (3)$$

The velocity and acceleration of point C could be determined by differentiation of the above equation:

$$V_{CZ}(t) = V_{MZ}(t) - \dot{\varphi}(t)r_{CM} \cos(\beta + \varphi(t)) \quad (4)$$

$$a_{CZ}(t) = a_{MZ}(t) - \ddot{\varphi}(t)r_{CM} \cos(\beta + \varphi(t)) + \dot{\varphi}^2(t)r_{CM} \sin(\beta + \varphi(t)) \quad (5)$$

The curve representing the acceleration component $a_{CZ}(t)$ calculated from equation (5) has been presented in Fig. 5.4.

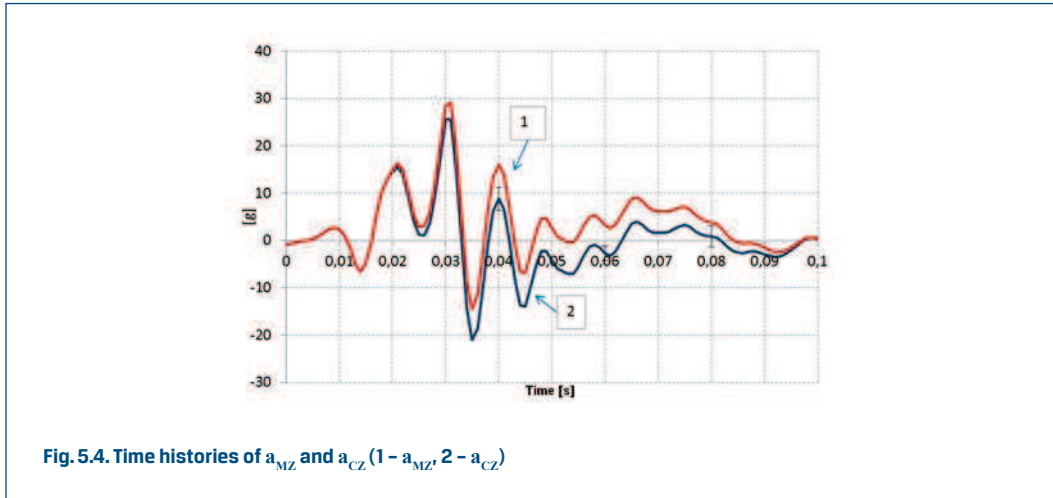

The differences between the values of acceleration of points C and M, visible in the graph, change with displacement of the rotating motorcycle and the acceleration sensor fixed on it. The calculation uncertainty interval has been shown in the graph in the form of a few vertical line segments. The lengths of these segments were determined with the use of the total differential method; such segments have also been shown in Figs. 5.5 and 5.6. The results of calculations of acceleration a_{CZ} shown in Fig. 5.4 will be used to compute the velocity and displacement of the centre of motorcycle mass by numerical integration.

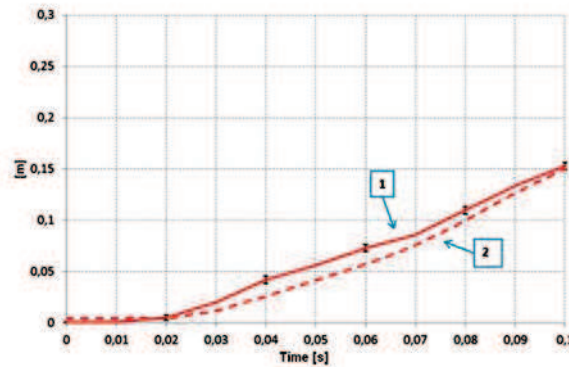

Fig. 5.5. Vertical displacement of the centre of motorcycle mass as a function of time

5.2. Displacement of the centre of motorcycle mass

Based on equation (3), the time history of the vertical displacement of the centre of motorcycle mass was determined. The calculation results have been shown in Fig. 5.5, where the $z_c(t)$ curve obtained from a frame-by-frame analysis (see Fig. 4.5) has been plotted as well. The dashed line 2 has been obtained from equation (3) while the continuous line 1 is identical to that of Fig. 4.5, i.e. it has been determined by analysing the video record.

The results of calculation of the displacement of the centre of motorcycle mass, obtained with the use of the two methods referred to above, differ from each other but the differences are quite small. Therefore, the calculations may be considered correct. The results of calculation of the $z_c(t)$ curve will be used to compute the energy balance of the frontal impact of a motorcycle against a motor car side.

5.3. Velocity of the centre of motorcycle mass

Equation (4) was used to calculate the V_{cz} values. The calculation results have been represented in Fig. 5.6 by the dashed line (denoted by 2). A curve $V_{cz}(t)$ representing the velocity of the centre of motorcycle mass, obtained from the frame-by-frame analysis, has also been plotted in the graph (continuous line, denoted by 1).

Results of calculation of the $V_{cz}(t)$ variation calculation results as presented in the graph, obtained with the use of both methods, do not considerably differ from each other and the differences are of the order of several or, in the worst cases, not more than twenty per cent. This is also illustrated by the calculation uncertainty interval, shown in the form of vertical line segments. Therefore, a conclusion may be drawn that the curve representing the velocity of the centre of motorcycle mass was correctly determined. The $V_{cz}(t)$ calculation results will be used to compute the energy balance of the motorcycle impact against a motor car side.

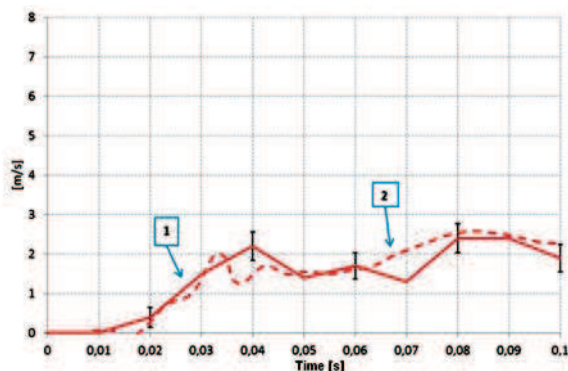

Fig. 5.6. Vertical component of the velocity of the centre of motorcycle mass

6. Dissipation of kinetic energy for the rotation and lifting of the motorcycle

The compilation of an energy balance constitutes an important stage of the analysis of a road accident. Two components of the balance are analysed at this stage. To determine the energy necessary for the motorcycle rotation, the following equation was used:

$$E_o(t) = \frac{1}{2} I_Y \dot{\varphi}^2(t) \quad (6)$$

where:

I_Y - mass moment of inertia of the motorcycle during the motorcycle rotation around the instantaneous centre of rotation.

The mass moment of inertia of the motorcycle relative to the instantaneous centre of rotation was calculated with the use of the Steiner theorem:

$$I_Y = I + mr_h^2(t) \quad (7)$$

where:

I - mass moment of inertia of the motorcycle relative to its central lateral axis

m - motorcycle mass

$r_h(t)$ - distance between the centre of motorcycle mass and the instantaneous centre of motorcycle rotation.

The calculations of the r_{h1} value were based on the schematic diagram shown in Fig. 4.2 and on Figs. 4.3 and 5.3.

The time history of the energy dissipated during the motorcycle rotation has been shown in Fig. 6.1.

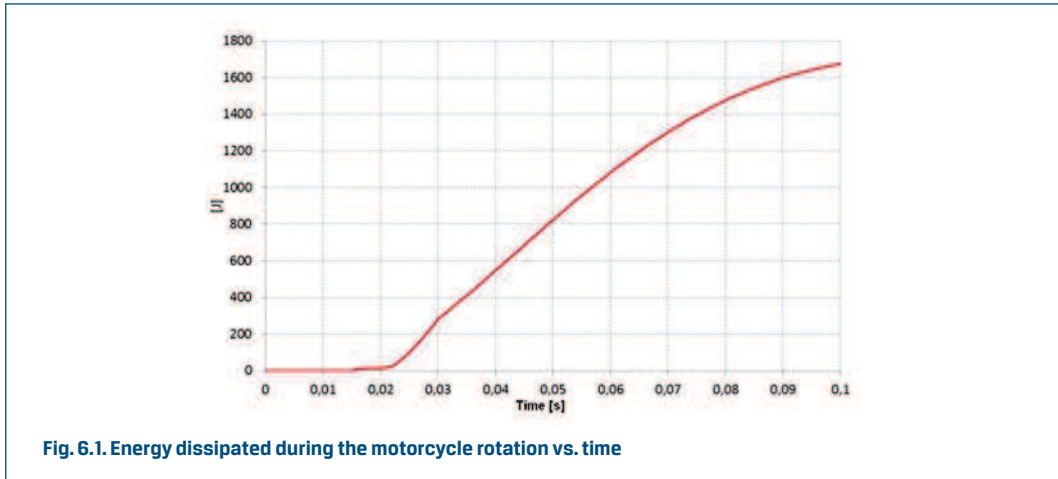

To determine the work necessary for the motorcycle lifting, the following equation was used:

$$W_{UM}(t) = mgz_c(t) \quad (8)$$

where:

g – acceleration of gravity

$z_c(t)$ – height of lifting of the motorcycle vs. time, determined by numerical integration.

The time history of the height of lifting of the motorcycle has been shown in Fig. 5.5. The calculated components of the energy dissipated during the motorcycle movement phase being analysed have been shown in Fig. 6.2.

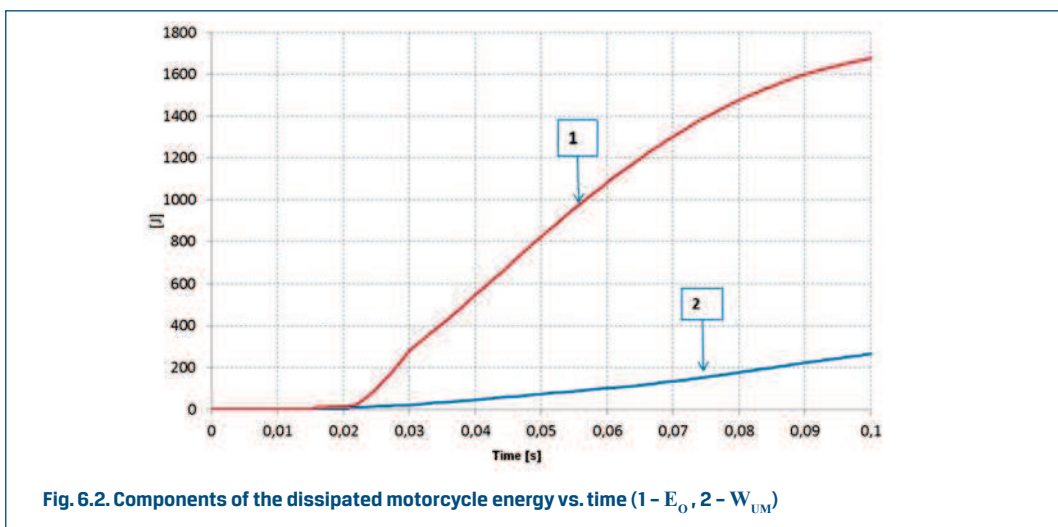

7. Recapitulation

The course of the motorcycle lifting and rotation at the analysed phase of the process of a motorcycle impact against a motor car side is of fundamental importance for the analysis of the entire road accident. An analysis of the process of lifting of the motorcycle, whose lifting velocity reaches a value of 2.5 m/s, constitutes a starting point for determining the location of the place where the motorcyclist hit the car side. The location of this place, in turn, is critical for the injury to motorcyclist's head.

The curves shown that represent changes in the angle of motorcycle rotation and the motorcycle lifting height provide a good basis for computing the energy dissipated during the accident and for predicting the place where motorcyclist's head would hit the motor car side. During the motorcycle rotation, the height of the instantaneous centre of rotation rises by more than 0.5 m for a period of 20 to 100 ms and the angle of motorcycle rotation reaches 80 degrees within about 360 ÷ 400 ms. Based on an analysis of the lifting and rotation process, a considerable part (about 15%) of the kinetic energy of the pre-impact movement, dissipated during the analysed phase of the accident, was determined. This part of the dissipated energy, the calculation of which has been described in this paper, in combination with the energy of motorcycle deformation, provide in turn a good basis for the calculation of the pre-impact speed at road accidents.

The aspects described above are important for the reconstruction of road accidents where motorcycles were involved. At the same time, the movement of a motorcycle having hit a motor car side considerably depends on the motorcycle design parameters, such as the height of the centre of mass or wheelbase. The calculations of motorcycle movement parameters carried out within this work will facilitate the modelling of the dynamics of the process of a motorcycle impact against a motor car side.

References

- [1] CHAWLA A., MUKHERJEE S., MOHAN D., DIPAN BOSE, PRAKASHRWAWAT, SAKURAI M., NAKATANI T.: *FE Simulations of motorcycle – car frontal crashes, validation and observations*. The 18th ESV Conference Proceedings, Nagoya, 2003.
- [2] GIDLEWSKI M., MATUSZEWSKI T., PROCHOWSKI L., WICHER J.: *Program poprawy bezpieczeństwa ruchu drogowego na Mazowszu (Program to improve the road safety in the Mazovia region)*. Gambit Mazowiecki, Warszawa, 24 July 2009.
- [3] GRANDEL J., SCHAPER D., BERG F. A.: *Untersuchung der Motorrad-, Fahrer- und Beifahrersicherheit bei Motorradunfällen mit zwei Motorradaufsassen – Teil 1*. ATZ – Automobiltechnische Zeitschrift, 89 (1987) 11.
- [4] GRANDEL J., SCHAPER D., BERG F. A.: *Untersuchung der Motorrad-, Fahrer- und Beifahrersicherheit bei Motorradunfällen mit zwei Motorradaufsassen – Teil 2*. ATZ – Automobiltechnische Zeitschrift, 89 (1987) 12.
- [5] KASANICKÝG.: *Nárazové skúšky jednostopových vozidiel, Znalectvo. Cestná doprava, elektronika, strojárstvo a iné technické odbory*. - ISSN 1335-1133. - Roč. 3, č. 1-2 (1998), s. 2-10.
- [6] KELLEY S. ADAMSON, GREGORY C. ANDERSON, PETER ALEXANDER, RALPH ARONBERG,.....: *Seventeen Motorcycle Crash Tests into Vehicles and a Barrier*. USA, SAE 2002-01-0551.
- [7] PRÓCHNIEWICZ H.: *Podręcznik motocyklisty A (Motorcyclist's handbook A)*. Publisher: Grupa Image, 2009.
- [8] Szydłowski H.: *Teoria pomiarów (The theory of measurements)*. Państwowe Wydawnictwa Naukowe, Warszawa, 1981.

-
- [9] UNARSKI J.: *Uderzenie motocykla w bok samochodu będącego w ruchu (Motorcycle impact against the side of a moving motor car)*. Paragraf na drodze, 2/2009, Wydawnictwo Instytutu Ekspertyz Sądowych (Publishers of the Institute of Forensic Research).
- [10] *Wypadki drogowe, Vademecum biegłego sądowego (Road accidents. Forensic expert's vade mecum)*. The 2nd issue, Wydawnictwo Instytutu Ekspertyz Sądowych (Publishers of the Institute of Forensic Research), Kraków, 2006.