

# Numerical thermodynamic optimization of supercritical coal fired power plant with support of IPSEpro software

WITOLD ELSNER\*  
ŁUKASZ KOWALCZYK  
MACIEJ MAREK

Institute of Thermal Machinery, Czestochowa University of Technology,  
Armii Krajowej 212, 42-200 Czestochowa, Poland

**Abstract** The paper presents a thermodynamic optimization of supercritical coal fired power plant. The aim of the study was to optimize part of the thermal cycle consisted of high-pressure turbine and two chosen high-pressure feed water heaters. Calculations were carried out using IPSEpro software combined with MATLAB, where thermal efficiency and gross power generation efficiency were chosen as objective functions. It was shown that the optimization with newly developed framework is sufficiently precise and its main advantage is the reduction of computation time on comparison to the classical method. The calculations have shown the tendency of the increase in efficiency, with the rise of a number of function variables.

**Keywords:** Thermodynamic optimization; Efficiency; Supercritical power plant; Simulation

## Nomenclature

$f$	–	optimization function
$lb$	–	lower boundary
$P_g$	–	power production by main generator
$P_{T-T}$	–	power production by T-T turbine
$Q_{in}$	–	heat input to the steam cycle
$Q_{out}$	–	heat output from the steam cycle

---

\*Corresponding Author. E-mail address: welsner@imc.pcz.czest.pl

$x_0$  – started point

### Greek symbols

$\eta_{boiler}$  – boiler efficiency  
 $\eta_{ge}$  – gross power production efficiency  
 $\eta_{th}$  – thermal efficiency

## 1 Introduction

Super critical steam plant design is rapidly becoming the preferred solution for the reduction of CO<sub>2</sub> emission. Current status of the technology achieves efficiencies of 45% (lower heating value (LHV) basis) with live steam parameters limited at about 30 MPa and 600 °C. This limit is mainly imposed by the materials of the boiler and high pressure turbine. However, prospects of technology development aim at 700 °C and higher pressures in the near future. The transition to ultra-supercritical parameters is a clear qualitative change as it could give rise to the net efficiency of electricity generation even by 7–8 p.p. [3]. However, such technology requires development of new high-temperature steel and overcoming the problem of very high steam bleed temperatures and the exergy loss in high and intermediate pressure regenerative heaters. To solve this problem Dong Energy [3] proposed modification of the thermal cycle named the master cycle [3]. The idea is to move the hot turbine bleeds to a tuning turbine, which supply feed water heaters with reduced exergy losses. Each solution should be subjected to the optimization aiming at reaching a compromise between plant efficiency and generation costs.

The aim of the paper is to present the results of initial numerical optimization of 900 MW ultra-supercritical coal-fired power plant based on the new technology AD700 [3]. The diagram of thermal cycle of the power plant is presented in Fig. 1. It consists of boiler, three main turbine sections, high pressure (HP), intermediate pressure (IP), low pressure (LP), additional tuning turbine (T-T), condenser, five preheaters of low pressure regeneration system, deaerator, and three preheaters of high pressure regeneration system. The calculations were done with the use of heat- and mass-balance commercial software package IPSEpro [6] combined with MATLAB [5]. Multiobjective optimization of the whole thermal cycle is a complex problem that is why for the current case it was decided to limit the analysis only to the part of the thermal cycle consisted of high-pressure turbine and two chosen high-pressure feed water heaters.

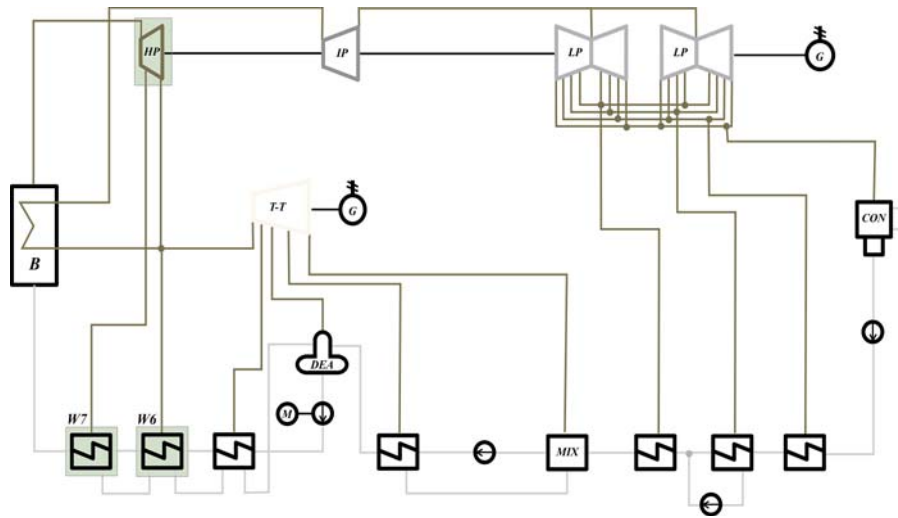

Figure 1. Scheme of ultra-supercritical steam cycle reference case: B – boiler; HP – high pressure turbine; IP – intermediate pressure turbine; LP – low pressure turbine; T-T – tuning turbine; G – generator, CON – condenser; DEA – deaerator; MIX – mixing heat exchanger; W6, W7 – preheaters; M – external motor.

The analysis was performed for four cases:

- I Optimization of bleed pressure ( $p_1$ ) and exit pressure ( $p_2$ ) of high pressure steam turbine (HP), with objective functions thermal cycle efficiency ( $\eta_{th}$ ) and gross power generation efficiency ( $\eta_{ge}$ ).
- II Optimization of feed water heater W6, with the thermal cycle efficiency ( $\eta_{th}$ ) and gross power generation efficiency ( $\eta_{ge}$ ) as the objective function.
- III Optimization of feed water heater W7, with the thermal cycle efficiency ( $\eta_{th}$ ) and gross power generation efficiency ( $\eta_{ge}$ ) as the objective function.
- IV Multiobjective optimization of all three elements, with the thermal cycle efficiency ( $\eta_{th}$ ) and gross power generation efficiency ( $\eta_{ge}$ ) as the objective function.

The basic values of the operation of the cycle are based on [4] and are listed in Tab. 1, while the operation parameters are given in Tab. 2. The mass flux of the live steam and the mass flux before T-T are the values taken from calculations.

Table 1. Basic values adopted during calculation.

Parameters	Value	Unit
Live steam parameters	Temperature	700 °C
	Pressure	35 MPa
Reheated steam parameters	Temperature	720 °C
	Pressure	7.4 MPa
High Pressure regeneration system	$dt_{out}$	2 °C
	$dt_{in}$	10 °C
Low Pressure regeneration system	$dt_{out}$	3 °C
	$dt_{in}$	10 °C
Pressure in the condenser	5	kPa
Feed water temperature	330	°C
Boiler efficiency	94.5	%
Gross electric power	900	MW

Table 2. Operation parameters of the power unit

Parameters	Representation	Value	Unit
Mass flux of live steam	$m$	584.17	kg/s
Thermal cycle efficiency	$\eta_{th}$	53.84	%
Gross electricity generation efficiency	$\eta_{ge}$	52.18	%
Mass flux before the T-T	$m_{T-T}$	110.49	kg/s
Electric power of T-T	$P_{T-T}$	41.67	MW

## 2 Methodology

Optimization capabilities available within IPSEpro software are very limited due to the number of tested parameters and the efficiency of calculations. In fact, the optimization is based on calculations of the entire space of solutions (with specified accuracy), and then the selection of the optimum value.

In case of the growing dimension of the decision variables such method is becoming too costly and should be replaced with a more rational optimization procedure. That is why, it was decided to use MATLAB environment, which provides algorithms for standard and large-scale optimization and is more flexible in terms of implementation of more complex optimization procedures [5]. The connection between IPSEpro and MATLAB was made using PSEExcel [6] and a special macro file, which allows for fluent data exchange in both directions. Such programs configuration ensures low time consumption, freedom in number of considered variables and full control of IPSEpro software. The connection scheme is shown in Fig. 2.



Figure 2. Scheme of connection between IPSEpro and MATLAB.

For the case of given analysis function  $fmincon$  has been chosen. This function attempts to find a constrained minimum of a scalar function of several variables starting at an initial estimate. It has a complex structure, however because some of non-linear terms were not used, the function took the simplified form:

$$x = fmincon(f, x0, lb, ub, options) , \quad (1)$$

$$options = optimset(DiffMinChange, DiffMaxChange, TolX) , \quad (2)$$

where, the  $optimset$  is a internal function to set or to change values in the structure options. The  $DiffMinChange$  and  $DiffMaxChange$  are respectively minimum and maximum change of variables for finite difference gradients.  $TolX$  is a termination tolerance of  $x$ .

As it was mentioned, for the case of the analysis, objective functions were the thermal cycle efficiency ( $\eta_{th}$ ) and the gross power generation efficiency ( $\eta_{ge}$ ). The functions are defined as following:

$$\eta_{th} = \frac{Q_{in}\eta_{boiler} - Q_{out}}{Q_{in}\eta_{boiler}} , \quad (3)$$

$$\eta_{ge} = \frac{P_T}{Q_{in}} , \quad (4)$$

where  $Q_{in}$ ,  $Q_{out}$  are the heat input to and output and , where  $P_T$  is a total power obtain from cycle and it is given by

$$P_T = P_g + P_{T-T} . \quad (5)$$

### 3 Results

The first task was to optimise the bleed pressure ( $p_1$ ) and exit pressure ( $p_2$ ) of high pressure steam turbine (Case I). The calculations were performed with IPSEpro (stand alone) and with IPSEpro-MATLAB and *fmincon* function. For calculations the minimum change of the variables was  $1.0e^{-3}$  and maximum change of the variables was 1.0. The termination tolerance of the optimization functions was  $1.0e^{-10}$ . The starting points as well as optimal points are given in Tab. 3. Figure 3 presents the surface of thermal efficiency as well as of gross power generation efficiency obtained for the range of bleed pressure  $11.0 < p_1 < 17.0$  MPa and for exit pressure  $6.2 < p_2 < 10.2$  MPa [2]. It is seen that the optimal value differs from the starting point and varies for each objective function. The most important is, however, that the results obtained with IPSEpro (stand alone) and with IPSEpro-MATLAB are almost identical. It means that optimization with MATLAB is precise enough and could be used in further calculations. It should be noted that the time of calculation for the last case takes about five minutes, which is much shorter in comparison with standard computations for all configurations, which takes about four hours.

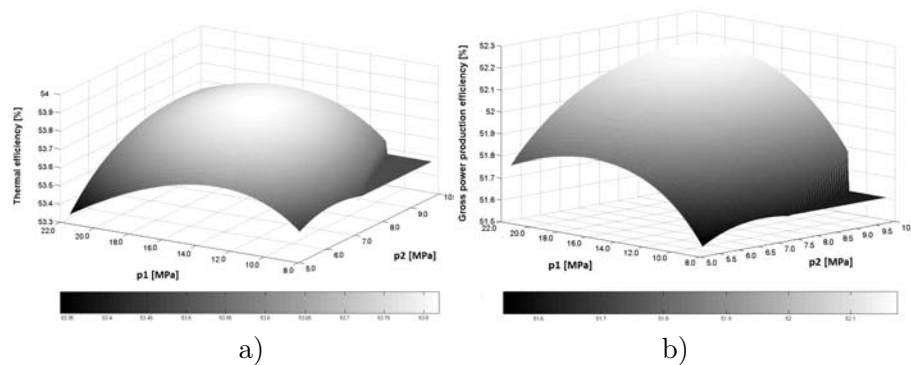

Figure 3. Thermal efficiency a) and gross power production efficiency b) as a function of  $p_1$  and  $p_2$ .

The similar analysis was performed for preheaters, Cases II and III. For both cases the analysis covers temperature difference at inlet ( $dt_{in}$ ) in the range 1–30 °C and temperature difference at the “hot” end ( $dt_{out}$ ) in the range 0.5–5 °C. For IPSEpro the step was equal 0.05 for  $dt_{out}$  and 0.1 for  $dt_{in}$ . For IPSEpro-MATLAB the step was assumed between  $1e^{-3}$  and 1. The results are given in Tab. 3, while Fig. 4 presents the surface

of gross power generation efficiency for W6 and W7, respectively. Also, for these calculations, it is seen that both methodologies give similar results. As might be expected, the optimal value is for the lowest available temperature differences, although the increase in efficiency is not significant. It is worth to consider the so-called *htc\_area*, which is defined as a product of heat transfer coefficient and heat transfer area. For the assumption that heat transfer coefficient does not vary with temperature, the *htc\_area* is a good estimation of heat transfer area. Figure 5 presents *htc\_area* as a function of  $dt_{in}$  and  $dt_{out}$ . It is seen that with the drop of these parameters the heat exchange area increases with power function. This leads to non-economical solutions. To avoid uneconomical solutions for all calculations the limitation of *htc\_area* must be included. It was assumed that the maximum value of *htc\_area* cannot be higher than 15% of the reference value.

Table 3. Comparison of optimal point between IPSEpro and IPSEpro-MATLAB fmincon.

Parameters	Starting point	Optimal point				Unit
		IPSEpro		IPSEpro-MATLAB fmincon		
		for $\eta_{th}$	for $\eta_{ge}$	for $\eta_{th}$	for $\eta_{ge}$	
Case I						
p1	13.461	15.7	20.2	15.76	20.08	MPa
p2	7.974	8.1	9.5	8.19	9.47	MPa
Case II						
W6 $dt_{in}$	10	6	6	6.13	6.13	°C
W6 $dt_{out}$	2	0.5	0.5	0.5	0.5	°C
Case III						
W7 $dt_{in}$	10	4.4	4.4	4.42	4.42	°C
W7 $dt_{out}$	2	0.5	0.5	0.5	0.5	°C

The last task was to perform multiobjective optimization, using IPSEpro-MATLAB, of high-pressure turbine and two chosen high-pressure feed water heaters (Case IV). The function variables were the same as used in previous steps, i.e.  $p_1$ ,  $p_2$ ,  $dt_{in}$  and  $dt_{out}$  for W6 and W7. Results for these analysis are presented in Tab.4.

For thermal efficiency the optimal value of  $p_1$  and  $p_2$  are 14.088 MPa and 8.293 MPa, what gives 1.672 MPa and 0.103 MPa discrepancy compared to the case were  $p_1$  and  $p_2$  were analysed, regardless of preheaters.

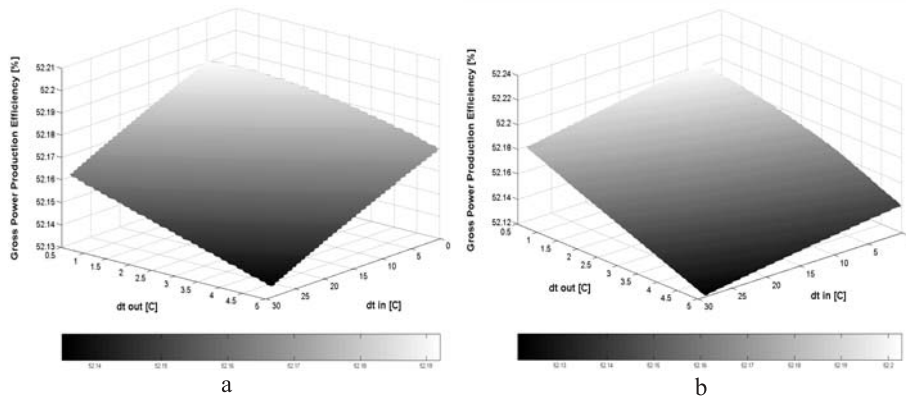

Figure 4. Gross power production efficiency for W6 a) and W7 b) as a function of  $dt_{in}$  and  $dt_{out}$  for W6.

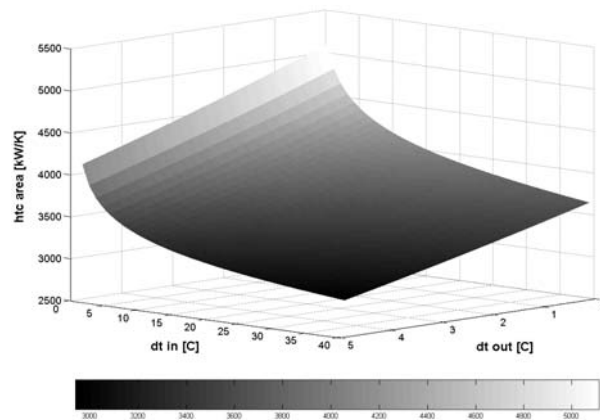

Figure 5.  $Htc\_area$  parameter as a function of  $dt_{in}$  and  $dt_{out}$ .

For the temperature,  $dt_{in}$  and  $dt_{ou}$ , the differences are less significant. The summary of this analysis are the data contained in Tab. 5, where comparison of efficiencies for consecutive cases is given. As it is seen gains are not stunning, however the tendency of increase in efficiency is evident. The aim of the research was, however, to show the possibilities of the developed computational framework, which allows in the further research to perform much more complex task. The obvious benefit is a reduction of computational time compared to the classical method. For the last case the optimization was done within less than 10 min, while using the IPSEpro



alone, it would be necessary to calculate more than  $2.38e^{12}$  elements, which would be impossible using the available computer resources.

Table 4. Optimal points for IPSEpro-MATLAB *fmincon* optimization process.

Parameters	Starting point	Optimal point		Unit
		IPSEpro-MATLAB <i>fmincon</i>		
		for $\eta_{th}$	for $\eta_{ge}$	
p1	13.461	14.088	14.396	MPa
p2	7.974	8.293	8.6	MPa
W6 dt_in	10	6.94	6.75	°C
W6 dt_out	2	0.5	0.5	°C
W7 dt_in	10	7.92	7.94	°C
W7 dt_out	2	0.5	0.5	°C

Table 5. Comparison of efficiency for considered cases.

Parameters	Optimal point		Unit
	IPSEpro-MATLAB <i>fmincon</i>		
	for $\eta_{th}$	for $\eta_{ge}$	
Reference case	53.84	52.18	%
Case I	53.86	52.35	%
Case II	53.88	52.22	%
Case III	53.90	52.24	%
Case IV	53.90	52.39	%

## 4 Summary

The aim of the analysis was to optimize a novel concept of super-critical coal fired power plant. The calculations were performed with IPSEpro (stand alone) and with IPSEpro-MATLAB and *fmincon* function. The connection between IPSEpro and MATLAB was made using PSExcel and a special macro file, which allows for efficient data exchange in both directions. Objective functions were the thermal cycle efficiency and the gross power generation efficiency. Such parameters as HP bleed pressure, HP exit pressure, *dt\_in* and *dt\_out* for preheaters W6 and W7 were under investigations.

It was shown that the results obtained with IPSEpro (stand alone) and with IPSEpro-MATLAB are almost identical. It means that optimization with MATLAB is precise enough and could be used in further calculations. The obvious benefit of the newly developed framework is the reduction of computational time compared to the classical method. Low time consumption is not the only advantage of IPSEpro-MATLAB method. It allows for the optimization with a number of function variables, in contrast to IPSEpro, which allows for two variables only.

For each considered case the optimal value differs from the starting point and is different for each analysed efficiency. For the preheaters the optimal value is for the lowest available temperature differences. However, with the drop of these parameters the heat exchange area increasing with power function, what leads to non-economical solutions. To avoid the increase in the cost of installation the limitation of *htc\_area* was included. Comparing the consecutive cases the tendency of the increase in efficiency is evident.

**Acknowledgements** The results presented in this paper were obtained from research work co-financed by the National Centre of Research and Development in the framework of Contract SP/E/1/67484/10 – Strategic Research Programme – Advanced technologies for energy generation: Development of a technology for highly efficient zero-emission coal-fired power units integrated with CO<sub>2</sub> capture.

*Received 1 August 2012*

## References

- [1] BLUM R., BUGGE J., KJAER S.: *Development of a PF Fired High Efficiency Power Plant (AD700)*.
- [2] ELSNER W., KOWALCZYK Ł., MAREK. M.: *Assessment of IPSEpro extended by MATLAB in Steam Turbine Cycle optimization*. *Nowa Energia* **26**(2012), 2, 154–155.
- [3] KJAER S., DRINHAUS F.: *A modified double reheat cycle*. Proc. ASME 2010 Power Conf., July 13-15, 2010, Chicago, Illinois.
- [4] ŁUKOWICZ H., DYKAS. S., RULIK S., STĘPCZYŃSKA K.: *Thermodynamic and economic analysis of a 900 MW ultra-supercritical power plant*. *Arch. Thermodyn.* **32**(2011), 3, 231–244
- [5] *Optimization Toolbox for use with MATLAB; User's Guide Version 2*. The Math Works.
- [6] <http://www.simtechnology.com/english/SimTech.php?page=sitemap.htm>