

dr inż. **Zdzisław SALAMONOWICZ**

dr inż. **Wojciech JAROSZ**

Szkoła Główna Służby Pożarniczej

ODŁAMKOWANIE PODCZAS WYBUCHU ZBIORNIKÓW Z LPG

Splinters forming during LPG tank explosion

Streszczenie

Działania ratownicze podczas zdarzeń z LPG wiążą się z wieloma zagrożeniami. Obecność zagrożeń zależy od sytuacji na miejscu zdarzenia jak również od podjętych działań gaśniczych i ratowniczych. Umiejętność obserwacji i prognozowania rozwoju sytuacji może zminimalizować ryzyko uszkodzenia i zniszczenia przyległych obiektów. Wcześnie podjęta decyzja o ewakuacji i wycofaniu na bezpieczną odległość może uratować życie wielu ludzi i strażaków. W artykule zostały opisane zagrożenia od odłamków powstających w trakcie wybuchu BLEVE. Opisano metodykę obliczania zasięgu odłamków powstających w trakcie wybuchów fizycznych zbiorników. Przedstawiono i omówiono wyniki eksperymentalnych wybuchów 11 kg zbiorników z LPG przeprowadzonych na poligonie. W większości przypadków typowa butla na „propan-butan” ulegała fragmentacji na kilka odłamków: w części cylindrycznej na 1-2 odłamki, dwie dennice oraz obręcz ochronną i zawór. Średnio w trakcie wybuchu butli 11 kg z LPG powstaje od 4 do 6 odłamków. Zasięg odłamków zależy w głównej mierze od kształtu i masy. Największe fragmenty przeleciały dystans około 70 m. Maksymalny zasięg rażenia odłamkami wynosił około 250 i 270 m dla płaskich części poszycia oraz zwartych elementów butli. W niektórych przypadkach zasięg przewyższał maksymalny obliczony promień rażenia, prawdopodobnie ze względu na wystąpienie zjawiska „frisbee”. W trakcie zdarzeń na otwartej przestrzeni Kierujący Działaniem Ratowniczym w sytuacji zagrożenia wybuchem 11 kg butli z propanem-butanem powinien wyznaczyć strefę niebezpieczną o promieniu nie mniejszym niż 300m.

Summary

The rescue operation during accidents with LPG vessels is connected with many threats. This threats depend from situation on accident place as well as firefighting and rescue activities. Skill of observation and forecasting of situation development can significantly minimise the risk of injury and destruction of objects. Early made decision about evacuation and withdrawal of attendance on safe distance can save many occupants and firefighter lives. The threats from splinters forming during BLEVE explosion was described in article. A method of calculating the range of fragments generated during physical explosions of tanks was called. The results of proving ground experiments with 11 kg LPG tank were showed and discussed. In most cases those type of vessels disrupt in cylindrical part of tank shell, which form few fragments of diversified shape and mass (1-2),

two end-caps and gas cylinder top. Average number of missiles for cylindrical tank is between 4 and 6. The range of fragments depend on shape and mass. The largest elements of tank could be found in distance 70 m from experimental position. Maximum range, 250 and 270 m, had flat pieces of tank shell and compact, small mass elements. In some cases maximum distance is longer than calculated maximum range, because “frisbee” effect for flat parts can occur. Incident commander during action in open space with typical 11 kg LPG tank, when exist high probability of explosion, should determine dangerous zone of at least 300 m.

Słowa kluczowe: LPG, odłamki, wybuch BLEVE

Keywords: LPG, splinters, missiles, BLEVE explosion

Introduction

The rescue operation during accidents with LPG vessels is connected with many threats. This threats depend from situation on accident place as well as firefighting and rescue activities. Depending on shape, size and type of breakdown, incident commander should consider during decision making process the possibility of:

- gas release to atmosphere and form of flammable vapour cloud with possibility of ignition mixture flammable gas - air,
- unconfined vapour cloud explosion (UVCE),
- jet fire (JF),
- boiling liquid expanding vapour explosion (BLEVE) [Salamonowicz, 2009].

Secondary effects of BLEVE will moreover:

- blast wave,
- fireball,
- splinters.

Skill of observation and forecasting of situation development can significantly minimise the risk of injury and destruction of objects. Early made decision about evacuation and withdrawal of attendance on safe distance can save many occupants and firefighter lives. Therefore, what distance is safe?

Theoretical

In majority BLEVE explosion is accompanied by blast wave, fireball (flammable gases) and fly splinters. Dangerous zones for every above mentioned threats are appointive

suitably from overpressure, radiant flux and kinetic energy of missiles. Zone in which life or health risks occur is defined by range of splinters formed during BLEVE explosion. Determination of zone in which overpressure and heat flux cause specified injuries is not difficult and is widely described in literature. Description of fragmentation and quantitative definition of danger zone is much more difficult.

The results of BLEVE explosion, being sequence of forming and spreading of splinters, depend from following factors:

- number and mass of splinters,
- velocity and range of missiles,
- direction of propagation of fragments,
- penetrative and destructive ability dependent on kinetic energy of splinters.

The number of missiles form from LPG vessels during BLEVE explosion depends type of destruction, shape of tank and energy of explosion. In general, vessel can disrupt as fragile failure and ductile failure. Typically, BLEVE will involve a ductile failure which will give less number of fragments than if it were fragile failure [Baum, 1999]. However, missiles formed during ductile failure have much greater potential to bring damage [Hauptmanns, 2001]. The number of splinters formed for cylindrical tank contains between two and fifteen and typically does not exceed five. Holden and Reeves (1985) analyzed 27 BLEVE events with cylindrical tanks. Four splinters were formed in 15% of events, three – in 37%, two - in 30% and one missile in 26% of events. In case of cylindrical vessels, initial damage usually follows in axial direction and tank is broken into two fragments. If there are three missiles, tank can be divided into two end-cap and central body or first can be divided into two pieces, one end-cap and the rest, and then the second projectile can be divided through the line between liquid and vapour phase (Fig. 1). Lees (1996) analyzed 7 events with spherical tanks in which number of formed missiles contained between 3 and 19.

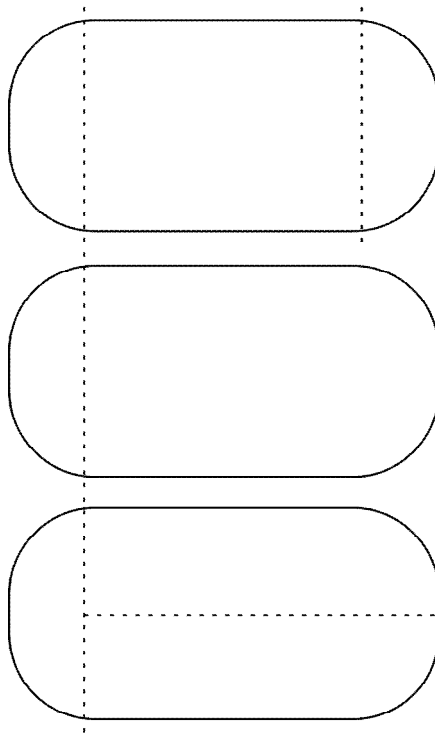

Fig. 1. General failure trend in cylindrical vessels [Figas, 2001].

Ryc. 1. Ogólna tendencja fragmentacji zbiorników cylindrycznych [Figas, 2001].

The total gas or vapour energy E inside pressure vessel is use up on formation blast wave and kinetic energy of splinters, which were formed as a result of separation individual elements from tank. For qualification of fragmentation effects accepts, then during BLEVE explosion form 4 missiles. The kinetic energy calculation of splinters is based on investigation, from which result that the coefficient of division of energy have value from 0,2 to 0,6 [Baum, 1988]. Therefore kinetic energy carries out:

$$E_k = 0,6 \div 0,2E \quad (1)$$

$$E = \frac{(p_1 - p_0)V}{\gamma - 1} \quad (2)$$

Next, from kinetic energy and mass of splinters, initial velocity of fragments carried out:

$$v_i = \left(\frac{2E_k}{m} \right)^{1/2} \quad (3)$$

where:

E_k kinetic energy

m	total mass of the empty tank	kg
p_0	ambient pressure outsider vessel	Pa
p_1	absolute pressure in vessel at failure	Pa
V	internal volume of tank	m^3
γ	ratio of specific heat	
v_i	initial missiles velocity	$m\ s^{-1}$

The simplest relationship for calculating missiles rang is:

$$R = \frac{v_i^2 \sin(2\alpha_i)}{g} \quad (4)$$

where:

g	gravitational acceleration	$m\ s^{-2}$
R	horizontal range	m
α_i	initial angle between trajectory and horizon	
v_i	initial missiles velocity	$m\ s^{-1}$

Splinters will travel on maximum distance when $\alpha_i = 45^\circ$.

$$R_{\max} = \frac{v_i^2}{g} \quad (5)$$

The above mentioned equation does not include air resistance coefficient. Some models include air resistance to range calculation, for example Clancey model (1976):

$$R = \frac{m^{1/3}}{ka} \ln \frac{v}{u} \quad (6)$$

where:

a	air resistance	(1,5 – 2,0)
k	empirical coefficient	(0,0014 – 0,002)
m_i	missiles mass	kg
u_i	end missiles velocity	$m\ s^{-1}$
v_i	initial missiles velocity	$m\ s^{-1}$

In some accidents distances were unexpectedly large. Baum (1999, 2001) explain this phenomenon as „rocketing” effect. If vapour forming from evaporating liquid remnant, escapes from open part of end-cap, then additional acceleration appears. This phenomenon is similar to gas release from rocket’s nozzle and it increase maximum distance. In case of flat splinters, range of their flight increases almost twice as the result of phenomenon called „frisbee”.

Experimental

Sensors to measure temperature and pressure were installed directly outside and inside tank. During experiments (heating to explosion) were measure temperature in vapour and liquid phase and pressure inside tank. Heating was performed with use of constructed burner stand and mounted burner of approx. 20 kW power, used during roof works.

The figure below present experimental vessel with sensor. Following parameters during investigation were measured:

- temperature liquid and vapour phase inside vessel,
- pressure inside vessel,
- test time,
- temperature outside vessel,
- temperature of vessel wall,
- splinters mass,
- distances between splinters and central point,
- pressure of blast wave.

Part of this parameters like splinters mass, pressure inside tank, distance and tank volume are used in this paper.

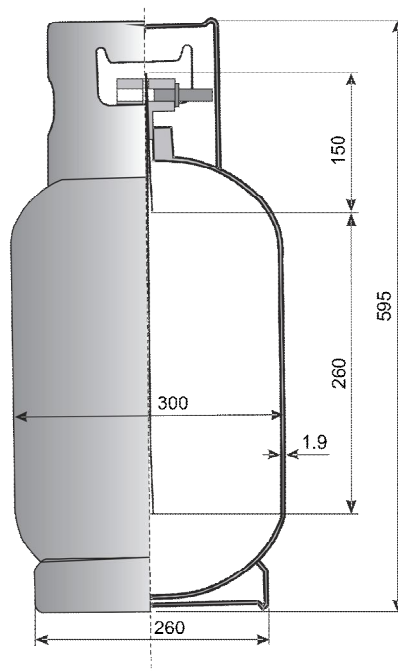

Fig. 2. Diagram of vessel with measuring sensors.

Ryc. 2. Zbiornik testowy z sensorami pomiarowymi.

Table below contain parameters our testing vessel.

Table. 1.

Technical parameters of vessel

Tabela. 1.

Parametry techniczne butli testowej

Parameter	Value
Capacity	27 dm ³ (11 kg)
Height	595 mm
Diameter	300 mm
Thickness of tank shell	1,9 mm
Material of tank shell	StE 355 DIN 17102
Maximum service pressure	2,5 MPa

Results and discussion

Carried out experiments show, that during BLEVE explosion, pressure vessel cracks into 5-6 parts (3-5 main missiles and few smaller fragments). All tanks were disrupt in similar way. In each case gas cylinder top with thread and two elliptic end-caps (heads) of vessel were ripped off. Whereat the upper part of tank break off with considerable fragment of tank

shell. Rest of tank shells formed 2 or 3 splinters. The direction and range of missiles was showed on figure 1 and 2. Pressure inside tanks before explosions were 42 bar and 72 bar.

The range of fragments depend on shape and mass. The largest elements of tank could be found in distance 70 m from experimental position. Maximum range, 250 and 270 m, had flat pieces of tank shell and compact, small mass elements (e.g. head on Fig. 3 and small piece on Fig. 4).

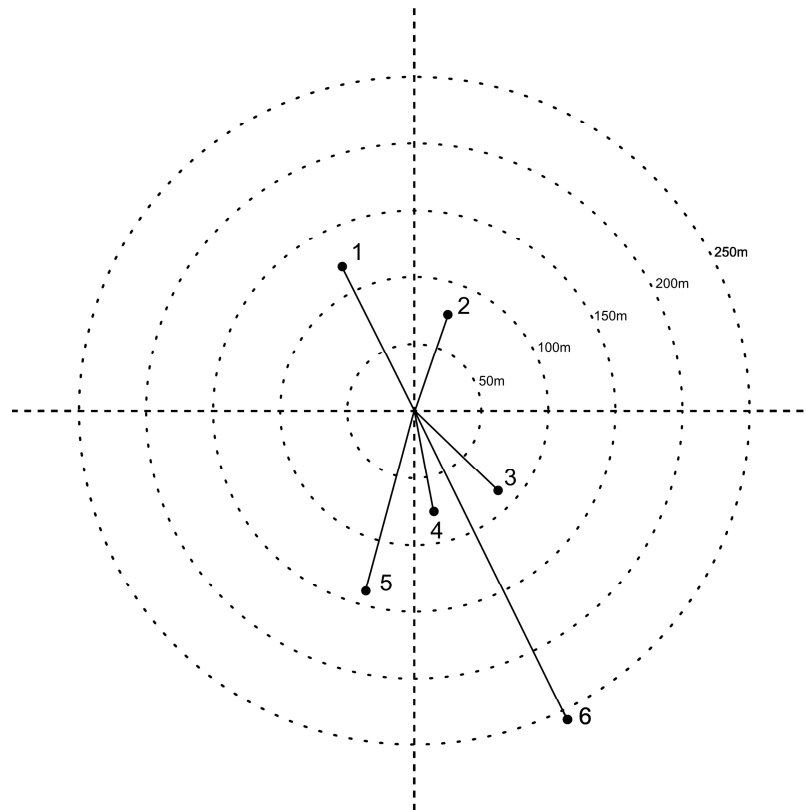

Fig. 3. Direction and range of missiles from LPG tank explosion – 1.

Rys. 3. Kierunek i zasięg odłamków po wybuchu zbiornika z LPG – 1.

Table. 2.

Splinters and range – 1.

Tabela. 2.

Odłamki i zasięgi – 1.

Nb.	Splinter	Range [m]	Mass [kg]	Theoretical max. range [m] ¹
1	part of the tank shell	122	2,34	49
2	safety collar	79	0,89	129
3	up head	91	2,10	55
4	down head	78	1,55	74

5	gas cylinder top	143	1,36	84
6	flat part of the tank shell	257	1,86	62

¹⁾ – from eq. (5); $E_k=0,6E$

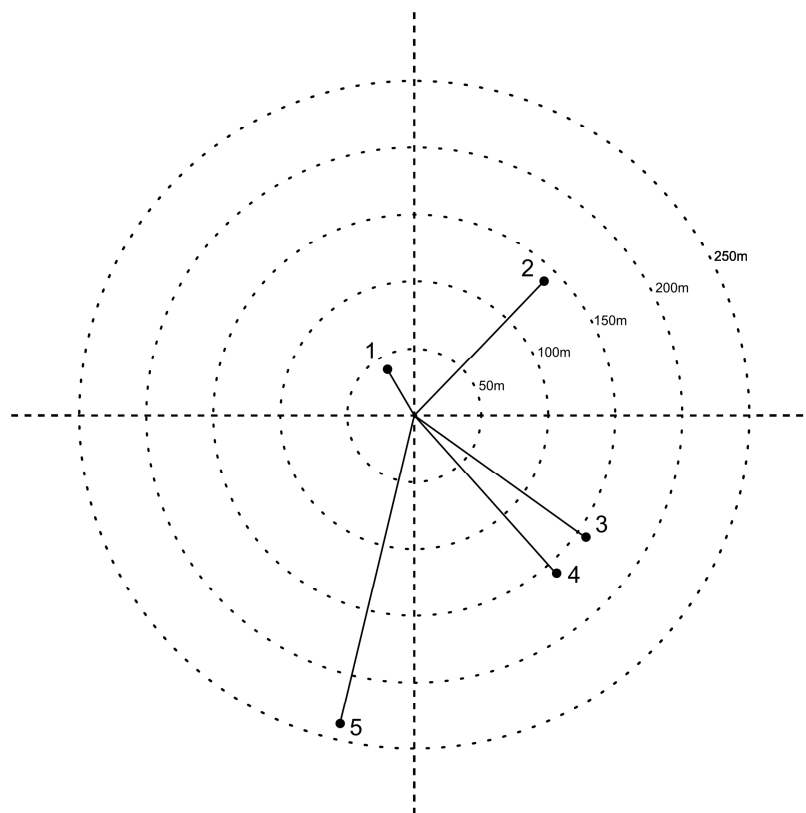

Fig. 4. Direction and range of missiles from LPG tank explosion – 2.

Ryc. 4. Kierunek i zasięg odłamków po wybuchu zbiornika z LPG – 2.

Table. 3.

Splinters and range – 2.

Tabela. 3.

Odłamki i zasięgi – 2.

Nb.	Splinter	Range [m]	Mass [kg]	Theoretical max. range [m] ¹
1	main part of the tank shell	44	5,68	34
2	down head	142	1,61	119
3	up head	154	2,37	81
4	safety collar	153	0,54	356
5	gas cylinder top	244	1,38	139



Fig. 5. Gas cylinder top with sensor outlet after explosion.

Ryc. 5. Głowica załadunkowa z czujnikami pomiarowymi po wybuchu.



Fig. 6. Safety collar after explosion.

Ryc. 6. Obręcz ochronna po wybuchu.



Fig. 7. Down head after explosion.

Ryc. 7. Dolna dennica po wybuchu.

Conclusions

The number of missiles formed during BLEVE explosion, as well as during other explosions, is impossible to foresee. All calculations and forecasts are based on statistical data, since main source of information about fragmentation is historical data assembled during many years.

However analysis of 11 kg cylindrical vessels splinters shows some regularities. In most cases those type of vessels disrupt in cylindrical part of tank shell, which form few fragments of diversified shape and mass (1-2), two end-caps and gas cylinder top. Average number of missiles for cylindrical tank is between 4 and 6.

In some cases maximum distance is longer than calculated from eq. 5, because “frisbee” effect for flat parts can occur.

Incident commander during action in open space with typical 11 kg LPG tank, when exist high probability of explosion, should determine dangerous zone of at least 300 m.

References

1. Baum, M.R. (1988). *Disruptive Failure of Pressure Vessel: Preliminary Design Guidelines for Fragment Velocity and the Extent of the Hazard Zone*. Journal of Pressure Vessel Technology, transaction of the ASME, 110, 168-176;

2. Baum, M.R. (1999). *Failure of a Horizontal Pressure Vessel Containing a High Temperature Liquid: the Velocity of End-cap and Rocket Missiles*. Journal of Loss Prevention in the Process Industries, 12, 137-145;
3. Baum M.R. (2001). *The velocity of large missiles from Arial rupture of gas pressurized cylindrical vessels*. Journal of Loss Prevention in the Process Industries, 14, 199-203;
4. Clansey V.J. (1976). *Liquid and vapour emission and dispersion, in: Course on Loss Prevention in the Process Industries*. Department of Chemical Engineering, Loughborough University of Technology;
5. Gubinelli G., Zanelli S., Cozzani V. (2004). *A simplified model for the assessment of the impact probability of fragments*. Journal of Hazardous Materials, 116, 175-187;
6. Hauptmanns U. (2001). *A procedure for analyzing the flight of missiles from explosions of cylindrical vessels*. Journal of Loss Prevention in the Process Industries, 14, 394-402;
7. Figas, M. (2001). *The Handbook of Hazardous Materials Spills Technology*. McGraw-Hill, New York;
8. Holden, P.L., Reeves, A.B. (1985). *Fragment hazards from failures of pressurized liquified vessels*. Chem. Eng. Symp. Ser., 93, 205-217;
9. Lees, F.P. (1996). *Loss Prevention in the Process Industries – Hazard Identification, Assessment, and Control*, 1-3, Butterworth-Heinemann, Oxford;
10. Leslie I.R.M., Birk A.M. (1991), *State of the art review of pressure liquified gas container failure models and associated projectile hazards*. Journal of Hazardous Materials, 28, 329-365;
11. Salamonowicz Z., *Rescue-firefighting actions during accidental collisions with Liquefied Petroleum Gas containing containers*, Polski Przegląd Medycyny Lotniczej, 15/1 (2009) 51-59;

st. kpt. dr inż. Zdzisław Salamonowicz ukończył Szkołę Główną Służby Pożarniczej w 2003 roku i uzyskał tytuł magistra inżyniera pożarnictwa w zakresie inżynierii bezpieczeństwa pożarowego. W 2005 roku ukończył studia na Wydziale Chemii Politechniki Warszawskiej z dyplomem inżyniera na kierunku technologia chemiczna, specjalność – materiały wysokoenergetyczne i bezpieczeństwo procesów chemicznych. W 2011 roku, na Wydziale Inżynierii Procesowej i Ochrony Środowiska Politechniki Łódzkiej otrzymał tytuł

doktora nauk technicznych w zakresie inżynierii chemicznej, specjalność - bezpieczeństwo procesowe. Obecnie pełni służbę w Szkole Głównej Służby Pożarniczej jako kierownik Zakładu Ratownictwa Chemicznego i Ekologicznego na Wydziale Inżynierii Bezpieczeństwa Pożarowego.

bryg. dr inż. Wojciech Jarosz jest oficerem PSP. W 1993 r. ukończył Szkołę Główną Służby Pożarniczej W Warszawie. W 2006 r. obronił doktorat Zagrożenia środowiska naturalnego powodowane przez zjawiska wykipienia i wyrzutu paliw w czasie pożarów zbiorników zawierających ciecze ropopochodne na Wydziale Inżynierii Środowiska Politechniki Warszawskiej. Od 1993 r. pracuje w Szkole Głównej Służby Pożarniczej zajmując kolejno stanowiska asystent, kierownik pracowni, adiunkt, prodziekan. Obszar zainteresowań naukowych to zagrożenia związane z materiałami niebezpiecznymi, szczególnie z ciekłymi węglowodorami oraz zagrożenia procesowe.

Recenzenci

dr inż. Adam majka

dr inż. Tadeusz Terlikowski, prof. nadzw.