

# A MODERNISED PROTOTYPE SYSTEM TO CONTROL THE SLIP OF DRIVING WHEELS (ASR) FOR VEHICLES WITH PNEUMATIC BRAKING SYSTEM

ADAM WOŚ<sup>1</sup>

The East European State Higher School

## Summary

The paper presents the construction of an ASR system that is to control the slip of driving wheels of a vehicle by making use of the construction, function and operation of the pneumatic braking system and the pneumatic suspension control equipment. The essence of the solution presented is the use of the piston-spring part of the spring brake chamber as an actuator in the anti-slip regulation system. In the modernised version of the prototype, the system is controlled by means of a pneumatic solenoid valve, which performs the functions of an ASR modulator. The above concept may be implemented in trucks, buses, or other vehicles provided with pneumatic braking systems. The prototype ASR system proposed was verified by computer simulation tests.

**Keywords:** pneumatic braking system, traction control systems ASR, pneumatic suspension system of a vehicle.

## 1. Introduction

In the existing ASR designs, the braking torque is obtained by operating the diaphragm part of the spring brake actuator of the appropriate rear driving wheel brake. A new concept of the ASR system was presented at the 9th International Brake Conference in Lodz in 2009. The proposed modification to the ASR system consisted of the use of the piston-spring part of the spring brake chamber to obtain the braking torque applied by the ASR system. Additionally, the system could cooperate with the engine control system, which reduced the vehicle driving torque. The main objective of the modernisation of the prototype ASR

---

<sup>1</sup> The East European State Higher School, Institute of Mechatronics, 4 Tymona Terleckiego Street, 37-700 Przemyśl, e-mail:adamwos@wp.pl

system as presented in this paper is to raise the speed of response of the ASR system proposed in 2009, as this speed is considered the basic parameter determining the system effectiveness.

## 2. Idea of the modernised prototype ASR system

The ongoing development in the engineering of automotive pneumatic system components, which may now be electrically controlled, has made it possible to modernise the construction of the ASR system presented in 2009. The new solution of the system under consideration has been shown in Fig. 1. In the new design, each of the two pairs consisting of the ASR modulator and the relay-control valve has been replaced with one electrically controlled relay-control valve (25), which simultaneously performs the functions of an ASR modulator. Thanks to this, one component in the control circuit has been eliminated and a pointless electric-to-pneumatic control signal conversion has been avoided. Thus, the system delay time has been reduced, i.e. the speed of response of the ASR system has been raised. As a result of development in the engineering and technologies of automotive vehicle suspension systems, pneumatic suspension systems have become increasingly popular in commercial vehicles. Therefore, active cooperation of the pneumatic suspension system with the ASR system has been additionally proposed. Development in the field of control of pneumatic suspension systems, enabling the systems to be electrically controlled as well, has provided the possibility for cooperation of such suspension systems with the anti-slip regulation within the ECAS (Electronically Controlled Air Suspension) system. The cooperation between the suspension and ASR system would consist in rapid growth of pressure in suspension bellows (controlled by the ECU ASR) during the operation of the ASR system. When designing the system presented, the engineers considered it important that commercially available elements should be used to build the prototype system, without the necessity to devise new units. The elements needed could be found in product catalogues of Wabco and Knorr-Bremse, which are leading manufacturers in this field. The elements proposed have been presented in a subsequent part of this paper.

A schematic diagram of the pneumatic system of a vehicle with the modernised traction control system (ASR) has been presented in Fig. 1.

## 3. Description of operation of the modernised ASR system

The modernised ASR system (see Fig. 1) includes the following major components:

- ECU ASR (item 18);
- ASR modulator (item 25);
- Relay-control valve to control the pneumatic suspension system (item 26);
- Diaphragm-spring brake actuator (item 13);
- Pneumatic suspension system components (item 27).

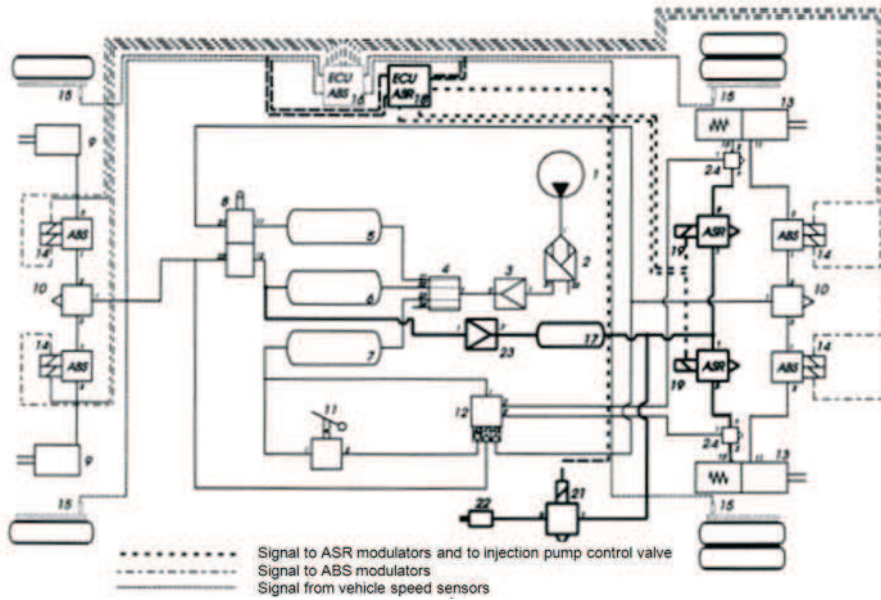


Fig. 1. Schematic diagram of a pneumatic braking system with the modernised ASR system.

Legend:

Item	Q-ty	Description
1	1	Air compressor
2	1	Air dryer with pressure regulator
3	1	Pressure limiter, 0.8 MPa
4	1	Four-circuit protection valve
5	1	Compressed air reservoir, 40 dm <sup>3</sup> , service brake, rear axle circuit
6	1	Compressed air reservoir, 40 dm <sup>3</sup> , service brake, front axle circuit
7	1	Compressed air reservoir, 20 dm <sup>3</sup> , secondary brake circuit
8	1	Brake foot valve
9	2	Piston chamber
10	2	Quick-release valve
11	1	Parking brake hand control valve
12	1	Relay valve
13	2	Diaphragm-spring chamber
14	4	ABS modulator
15	4	Vehicle wheel speed sensor
16	1	ECU (electronic control unit) ABS
17	1	Compressed air reservoir, 20 dm <sup>3</sup> , engine control system
18	1	ECU (electronic control unit) ASR
20	2	Two-way valve
21	1	Control valve to operate the actuator of the injection pump control rack
22	1	Actuator of the injection pump control rack
23	1	Pressure limiter, 0-0.6 MPa
25	2	ASR modulator (electrically controlled relay-control valve)
26	2	Electrically controlled relay-control valve of the pneumatic suspension system
27	2	Pneumatic suspension system components

In the version as presented in 2009, the ASR system operated, via a complex electro-pneumatic control system, the spring part of the rear wheel brake actuator, which normally (without the intervention of the ASR system) performed the functions of a parking or emergency brake.

In the modernised version proposed here (see Fig. 1), each of the two pairs consisting of the ASR modulator and the air-operated relay control valve has been replaced with a new relay-control valve (25), which is electrically controlled. When the ASR system is active, the spring part of the brake actuator is operated as follows. Based on the logics of the control algorithm, the electric signal generated by the ASR electronic control unit (18) is fed to the control terminal of the relay-control valve (25), which performs the functions of an ASR modulator. The relay-control valve (25) having been actuated causes de-aeration of the piston-spring part of the brake actuator (13). As a result of expansion of the actuator spring, a force is generated in the piston rod, which causes a braking torque to be applied to the appropriate driving wheel. This in turn reduces the slip and improves the traction properties of the driving wheels. When the signal operating the relay-control valve (25) disappears then the valve reopens the supply of compressed air to the chamber of the piston-spring part of the brake actuator (13), the actuator spring is compressed back, and the wheel brake is released.

A advantage of this solution as against that proposed in 2009 is the fact that one component in the control circuit has been eliminated and, simultaneously, the electric control signal does not have to be converted anymore into a pneumatic one. Thus, the system delay time has been reduced by about 40%, i.e. the speed of response of the ASR system has been considerably raised. In addition to this, active cooperation of the pneumatic suspension system of the vehicle with the ASR system has been proposed in this prototype system version. Within this cooperation, the control pulses generated when the ASR system is active are fed not only to the ASR modulator but also to the pneumatic suspension control valve. This causes a rapid growth of pressure in the appropriate suspension bellows, which results (according to d'Alembert's principle) in a temporary extra load on the driving wheels and, in consequence, an improvement in the traction properties of the vehicle.

The pneumatic suspension springs and spring control valves operate to non-linear performance curves; therefore, the extra load on the driving axle is difficult to be precisely predicted. However, it may be easily determined on a weighing stand. Measurements have shown that the active cooperation between the ASR system and the suspension system may temporarily increase the driving axle load by up to 20%.

Wabco uses the pneumatic suspension system to improve the traction properties of a starting truck by temporarily raising the lift axle, in order to increase the force of adhesion between the driving wheel and the road surface.

The modernised ASR system was subjected to simulation tests, with the following differences in comparison with the system version of 2009 having been introduced to the simulation program, according to the above:

- Reduction of the system delay time by about 40%;
- Increase in the load of the driving axle by up to 20%.

The other parameters that might affect the process were kept unchanged. The simulation results have been presented in Fig. 3, to compare with Fig. 2, where the simulation results obtained for the system version of 2009 have been shown.

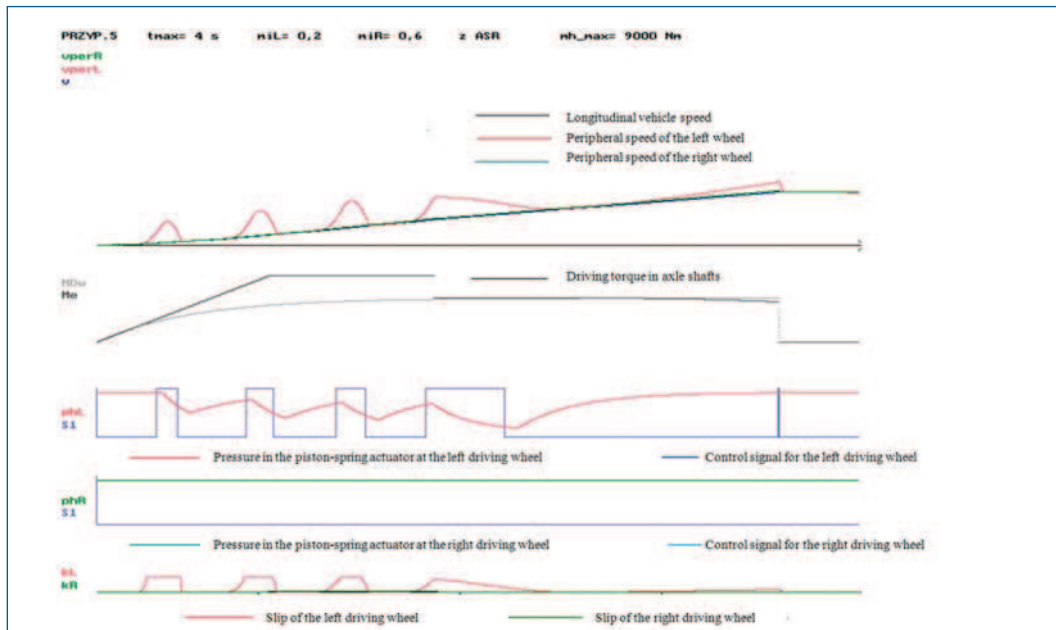


Fig. 2. Simulation of a vehicle start, in second gear, on a "μ-split" road surface, at an adhesion coefficient of  $\mu_x = 0.2/0.6$ , with the ASR system in the 2009 version.

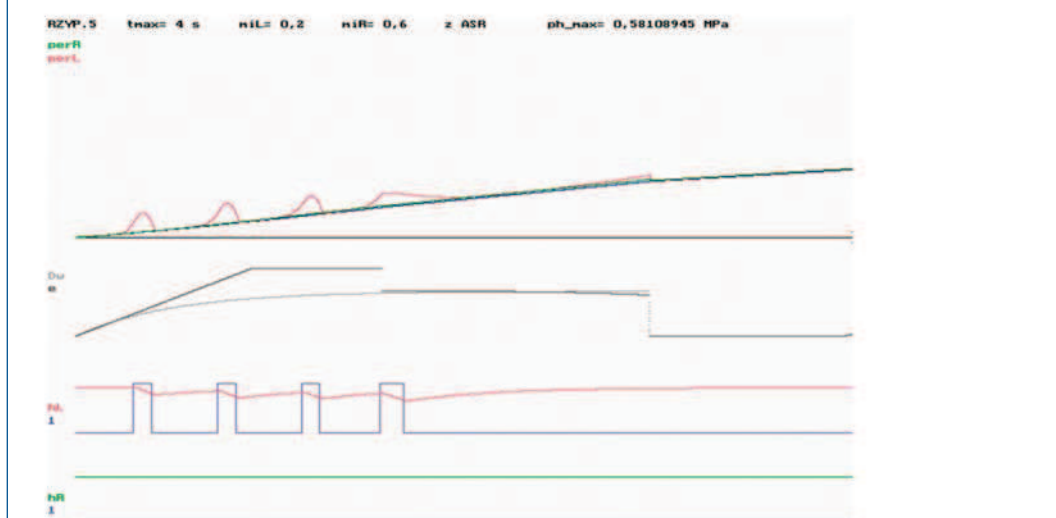


Fig. 3. Simulation of a vehicle start, in second gear, on a "μ-split" road surface, at an adhesion coefficient of  $\mu_x = 0.2/0.6$ , with the modernised ASR system, for the parameters as described herein.

A comparison between the two graphs reveals the following:

- Shortening of the regulation time;
- Reduction of the total slip of the wheel moving on the road surface with a low adhesion coefficient;
- Reduction of the pressure drop in the spring part of the brake actuator during the regulation process.

Attention should be paid to the fact that simulation tests are not very accurate because of the inherent program simplifications. As a result result of such tests, only the system design may be generally checked for correct functioning and the process parameters may be roughly estimated. Better accuracy may be achieved when road tests are carried out in actual field conditions with the use of a vehicle provided with appropriate measuring equipment.

## 4. Components of the modernised ASR system

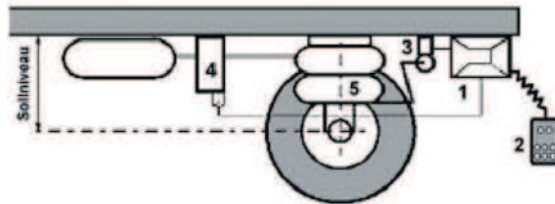
The elements used as components of the ASR system proposed are standard parts selected from manufacturer's catalogue.

### 4.1. The valve that may serve as an electrically controlled ASR modulator

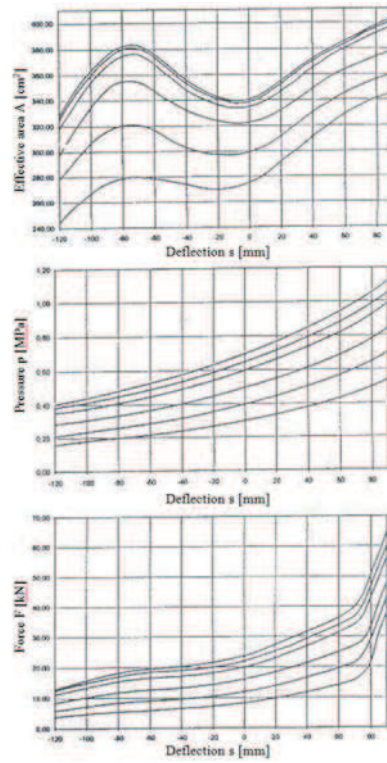


Fig. 4. Control valve 480 204 ... 0 (Wabco).

#### 4.2. Pneumatic suspension system of the vehicle



**Fig. 5. Schematic diagram of the ECAS (Electronically Controlled Air Suspension) system:**  
1 - controller; 2 - manual control unit; 3 - position sensor; 4 - pneumatic solenoid valve;  
5 - pneumatic suspension bellows.



**Fig. 6. Static performance curves of pneumatic suspension bellows.**

## 5. Conclusions

The work on the modernised ASR system to control the slip of driving wheels provided grounds to formulate conclusions as given below.

1. The simulation test results have shown the functioning of the system designed as proposed to be correct.
2. The simulation has confirmed the expectations that the application of electro-pneumatic components would improve the anti-slip regulation process.
3. The active cooperation of the pneumatic suspension system with the ASR system has been found to be possible. However, the simulation tests have shown the effect of this cooperation to be rather limited.
4. Efforts should be made to build a real functioning prototype ASR system.
5. At the final stage of the research work, road tests should be carried out on a vehicle provided with a prototype of the ASR system developed.

## References

- [1] BURCKHARD M.: *Fahrwerktechnik: Bremsdynamik und Pkw-Bremsanlagen*, Vogel Buchverlag Wuerzburg 1991.
- [2] BURCKHARDT M.: *Fahrwerktechnik: Radschlupf-Regelsysteme* Vogel Buchverlag Wurzburg 1993.
- [3] GOŁASZEWSKI A., SURMIŃSKI K., SZCZEPANIAK C., SZOSLAND A.: *ASR, jako kontynuacja rozwoju ABS dla pojazdów z pneumatycznym układem uruchamiania hamulców*, Konferencja Hamulcowa 2001 Łódź 2001.
- [4] SZCZEPANIAK C.: *Podstawy modelowania systemu: człowiek - pojazd - otoczenie*, PWN Warszawa 1999.
- [5] SZCZEPANIAK C.: *Urządzenia przeciwblokujące. Studium teorii i konstrukcji*, Zeszyty Naukowe nr 76, Instytut Transportu Samochodowego Warszawa 1992.
- [6] SZCZEPANIAK C., SZOSLAND A., SURMIŃSKI K.: *Prace nad rozwojem urządzeń ABS i ASR prowadzone w Instytucie Pojazdów Politechniki Łódzkiej*, Archiwum Motoryzacji 1 - 2/2001.
- [7] SZOSLAND A., DYCHTO R.: *Wpływ parametrów dynamiki pojazdu na działanie układu ESP*, Konferencja Hamulcowa, Łódź 2004.
- [8] SZOSLAND A., WOŚ A.: *Prototyp urządzenia dla pojazdu z pneumatycznym układem hamulcowym*, Konferencja Hamulcowa, Łódź 2009.
- [9] WICHER J.: *Zagadnienia bezpieczeństwa samochodu*, Oficyna Wydawnicza Politechniki Warszawskiej, Warszawa 1998.
- [10] WRZESIŃSKI T.: *Hamowanie pojazdów samochodowych*, WKiŁ W-wa 1978.
- [11] KNORR - BREMSE - materiały firmowe 2011.
- [12] WABCO Inform 2011 - materiały firmowe.