

Energy efficiency for the transcritical compression CO₂ cycle with the use of the ejector as the first stage of the compression

JOACHIM KOZIOŁ*
WIESŁAW GAZDA
ŁUKASZ WILŻYŃSKI

Silesian University of Technology, Institute of Thermal Technology,
Konarskiego 22, 44-100 Gliwice, Poland

Abstract An analysis of energy efficiency for transcritical compression unit with CO₂ (R744) as the refrigerant has been carried out using empirical operating characteristics for the two-phase ejector. The first stage of the refrigerant compression is carried out in the ejector. The criterion adopted for the estimation of energy efficiency for the cycle is the coefficient of performance COP. The analysis is performed for the heat pump and refrigeration systems. The results of COP for the systems with the ejector has been compared with the COP_L values for the single stage Linde cycle.

Keywords: Transcritical CO₂ cycle; Ejector; Energy efficiency

Nomenclature

A	–	minimum area of cross-section, m ²
COP	–	coefficient of performance
d	–	diameter, mm
h	–	specific enthalpy, kJ/kg
\dot{m}	–	mass flow rate, kg/s
P	–	power, kW
p	–	pressure, MPa
t	–	temperature, °C
T	–	temperature, K
\dot{Q}	–	capacity, kW

*Corresponding author. E-mail address: joachim.kozioł@polsl.pl

Greek symbols

ρ	–	density, kg/m ³
χ	–	mass ejection ratio
φ	–	velocity coefficient
Π	–	dimensionless compression ratio
η	–	efficiency
Δ	–	distance between the output of the nozzle and the input of the mixing chamber, mm

Subscripts

<i>com</i>	–	compressor
<i>cond</i>	–	condenser
<i>d</i>	–	nozzle
<i>D</i>	–	diffuser
<i>ej</i>	–	ejector
<i>el</i>	–	electric motor
<i>ev</i>	–	evaporator
<i>HP</i>	–	heat pump
<i>is</i>	–	isentropic
<i>L</i>	–	Linde cycle
<i>ls</i>	–	liquid separator
<i>m</i>	–	mixing chamber
<i>R</i>	–	refrigerating unit (refrigerator)
<i>tv</i>	–	throttling valve
<i>v</i>	–	volumetric

1 Introduction

In the years 2008–2010 the Institute of Thermal Technology in collaboration with the SINTEF Institute in Trondheim (Norway), carried out research for the estimation of energy and technical efficiency of the use of transcritical compression unit with CO₂ (R744) as the refrigerant for compression heat pumps and/or refrigerating units. The theoretical analysis has been carried out at the Institute of Thermal Technology and the experimental measurements were carried out at the SINTEF Institute in Trondheim.

One of the research aims was to determine the influence of selected constructional parameters of the ejector and operating parameters of the transcritical compression cycle with CO₂ on the energy efficiency of the cycle [4]. The effects have been estimated by the coefficient of performance COP_{HP} of the heat pump and the COP_R of the refrigerating unit.

In the performed investigations the ejector is the first compression stage. The second compression stage is performed in the typical compressor [6,7].

2 The analysed transcritical CO₂ cycle

The scheme of the installation in which the analysed cycle takes place is shown in Fig. 1 and the p-h diagram of the thermodynamic cycle is shown in Fig. 2. The numbers in the figures indicate the characteristic points of the cycle. They are also the symbols of the thermal parameters of the refrigerating agent: pressure, temperature, enthalpy, density, mass flow rate. These symbols have been further used in the equations in the text.

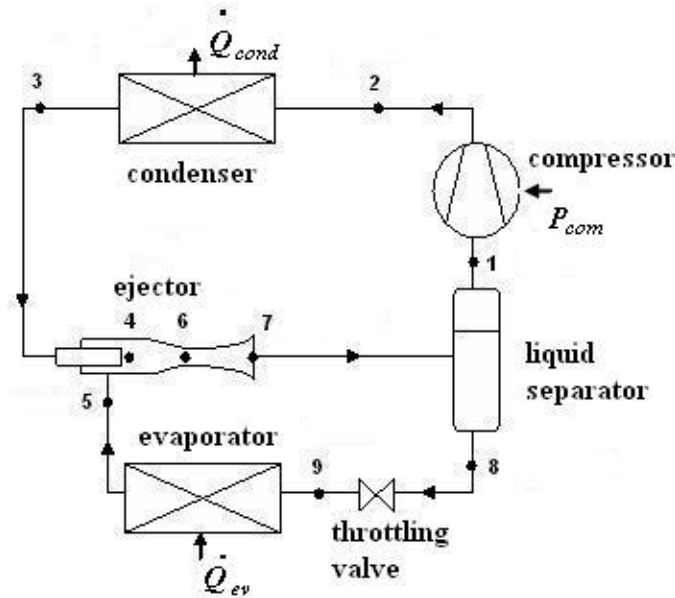

Figure 1. Schematic diagram of the refrigerating system with a two-phase ejector as the first compression stage.

3 Operating characteristics of the ejector

The operating characteristics of the ejector is determined by the dimensionless relationship between the compression ratio and the ejection ratio and by the parameters which influence the velocity coefficients of the refrigerant in the nozzle, mixing chamber and diffuser. The compression ratio of the refrigerant is defined as:

$$\Pi = \frac{p_7 - p_5}{p_3 - p_5}. \quad (1)$$

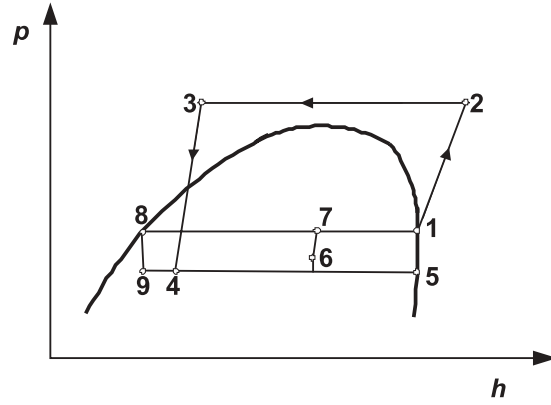

Figure 2. Cycle of the refrigerating system with a two-phase ejector as the first compression stage in the pressure-enthalpy diagram.

In [1] the following equation has been proposed to describe the ejector performance line:

$$\Pi = 2 \frac{\varphi_d}{\varphi_m} \frac{A_d}{A_m} \left[\varphi_d \varphi_m \varphi_D - \left(1 - \frac{\varphi_D}{2\varphi_d} \right) \frac{A_d}{A_m} (1 + \chi_v)^2 \right], \quad (2)$$

where:

$$\chi_v = \chi \frac{\rho_3}{\rho_5}. \quad (3)$$

Equation (2) is applicable for the water-air ejector. It is also relatively often used [2,3] in the calculations for the ejectors with the two-phase flow of the fluid.

For the assumption that the velocity coefficients are constant, Eq. (2) may be transformed into [5]:

$$(1 + \chi_v)^2 = A + B\Pi, \quad (4)$$

where:

$$A = \frac{2\varphi_d^2 \varphi_m \varphi_D}{(2\varphi_d - \varphi_D) \frac{A_d}{A_m}} \quad \text{and} \quad B = - \frac{\varphi_m}{\left(\frac{A_d}{A_m} \right)^2 (2\varphi_d - \varphi_D)}. \quad (5)$$

Coefficients A and B in Eq. (4) have been determined by statistic methods with the use of the measurements results obtained at SINTEF. In the analysis various values of the following measured parameters have been taken

into consideration: p_3 , p_5 , and p_7 (influencing the dimensionless compression ratio Π), and $\dot{m}_1, \dot{m}_5, t_3, t_5$ (influencing the volumetric ejection ratio). Additionally, various values of the distance Δ between the output of the nozzle and the input of the mixing chamber have been taken into consideration in the analysis. A linear approximation of Eq. (4) and non-linear influence of Δ on $(1 + \chi_v)^2$ has been confirmed [5].

Finally, in [5] the following empirical characteristics of the ejector has been obtained:

$$(1 + \chi_v)^2 = 3.8818 + 62.565\Delta/d_d - 7.2568 (\Delta/d_d)^2 + \left(52.993 + 586.15\Delta/d_d - 66.52 (\Delta/d_d)^2\right) \Pi \quad (6)$$

for $R^2 = 0.655$.

Equation (6) has been determined with 97 measurement points. It is applicable to the following range of changes of the parameters: $p_5 = 3.6\text{--}5.2$ MPa, $p_3 = 7.3\text{--}10.8$ MPa, $p_7 = 4.1\text{--}5.5$ MPa, $t_3 = 25\text{--}44$ °C, $t_5 = 4\text{--}19$ °C, $\Delta/d_d = 1\text{--}6$, $\Pi < 0.1$, $A_d/A_m = 0.0625$.

4 Methodology of calculations

Calculations have been carried out with the following assumptions:

- specified value of the condenser capacity \dot{Q}_{cond} ;
- specified value of Δ/d_d ratio;
- specified cycle parameters p_3, p_5, p_7 ;
- degree of refrigerant quality is: $x_3 = 0, x_5 = 1, x_8 = 0$;
- equal enthalpies in the throttling process in the valve: $h_8 = h_9$.

For the assumed pressures, the compression ratio Π for the ejector has been calculated from Eq. (1) and the volumetric ejection ratio χ_v has been calculated from Eq. (6). The mass ejection ratio χ has been calculated from the transformed Eq. (3). The mass flow rate has been calculated from the balance of the condenser:

$$\dot{m}_3 = \frac{\dot{Q}_{cond}}{h_2 - h_3} \quad (7)$$

with

$$\dot{m}_5 = \chi \dot{m}_3 . \quad (8)$$

The evaporator capacity has been calculated from the energy balance:

$$\dot{Q}_{ev} = \dot{m}_5 (h_5 - h_9) = \dot{m}_5 (h_5 - h_8) . \quad (9)$$

The enthalpy of the refrigerant on the input of compressor has been calculated from the balance of the liquid separator:

$$h_1 = (1 + \chi) h_7 - \chi h_8 . \quad (10)$$

The enthalpy of the refrigerant on the output of ejector has been calculated from the energy balance of the ejector:

$$h_7 = \frac{h_3 - \chi h_5}{1 + \chi} . \quad (11)$$

The input power to the compressor is calculated from the equation:

$$P_{com} = \frac{\dot{m}_3 (h_2 - h_1)}{\eta_{el}} , \quad (12)$$

where

$$h_2 = h_1 + \frac{(h_{2is} - h_1)}{\eta_{is}} . \quad (13)$$

It is proposed to calculate the isentropic efficiency from the equation:

$$\eta_{is} = 2.8 - 1.8 \frac{T_{cond}}{T_{ls}} . \quad (14)$$

Finally, the values of the coefficient of performance have been calculated from the equations:

$$COP_{HP} = \frac{\dot{Q}_{cond}}{P_{com}} , \quad (15)$$

and

$$COP_R = \frac{\dot{Q}_{ev}}{P_{com}} . \quad (16)$$

5 Results and discussion

The calculations have been carried out with the use of the Engineering Equation Solver program. The following constant values have been assumed: $p_3 = 9$ MPa , $t_3 = 35$ °C, $\dot{Q}_{cond} = 5$ kW and different values p_5 , p_7 and ratio Δ/d_d . The calculation results have been shown in respective

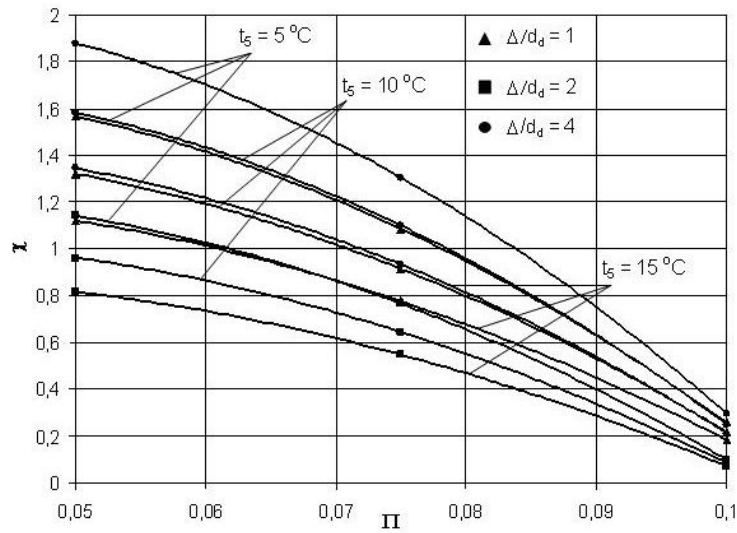

Figure 3. The ejection ratio χ for the refrigerating system with a two-phase ejector as the first compression stage.

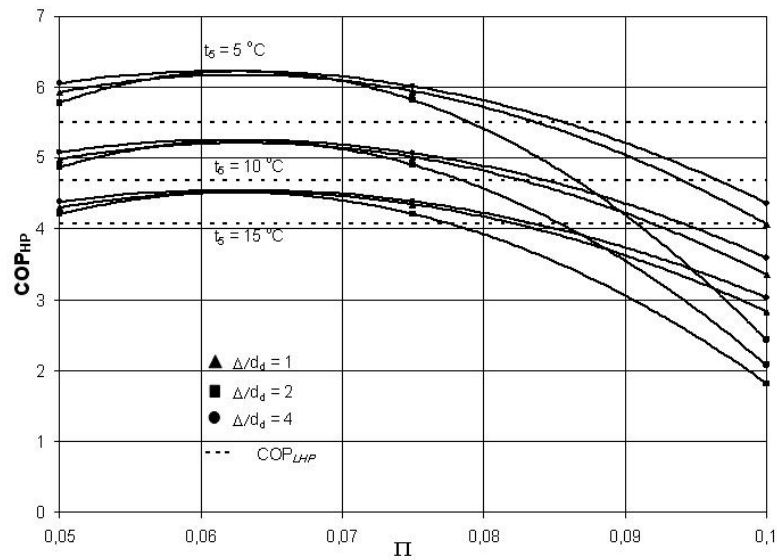

Figure 4. Coefficient of performance for a heat pump with a two-phase ejector as the first compression stage.

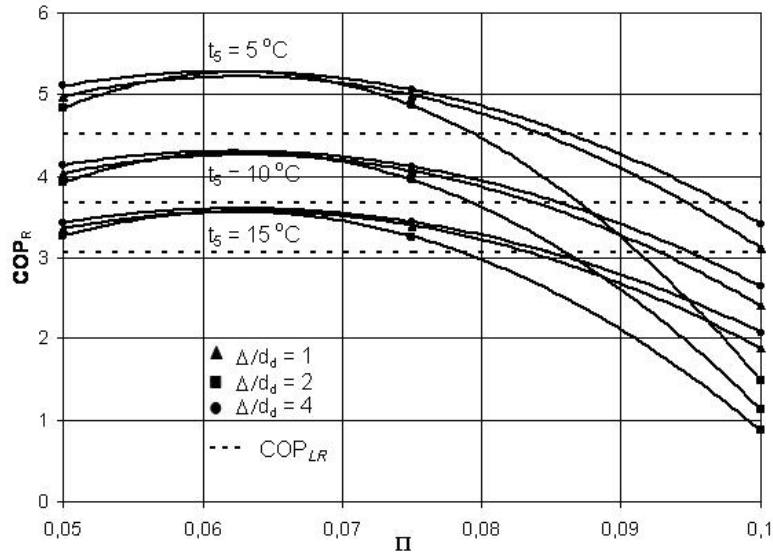

Figure 5. Coefficient of performance for a refrigeration system with a two-phase ejector as the first compression stage.

figures. Figure 3 shows the influence of the parameters in point 5 and 7 of the cycle and the value of Δ/d_d ratio on the ejection ratio χ . The obtained values COP_{HP} and COP_R have been shown in Fig. 4 and 5, respectively.

In order to compare the energy efficiency in cycles equipped with the ejector and the typical Linde cycles, COP_{LHP} and COP_{LR} have been additionally determined, which correspond to the condensing pressure of the refrigerant $p_3 = 9$ MPa and different evaporating parameters. The values COP_{LHP} and COP_{LR} are also given in Fig. 4 and Fig. 5.

Figures 4 and 5 show that the best coefficient of performance (COP) is obtained for Π from the range $[0.06, 0.07]$. The use of the Linde cycle is better for the discussed range of value of Δ/d_d ratio than using a cycle with ejectors for $\Pi > 0.085$.

Acknowledgements The paper is supported by a grant PNRF-150-AI-1/07 from Norway through the Norwegian Financial Mechanism.

Received 28 August 2010

References

- [1] SOKOŁOW J.J., ZINGER N.M.: *Ejectors*. WNT, Warsaw, 1965.
- [2] BERGANDER M., BUTRYMOWICZ D., KARWACKI J., WOJCIECHOWSKI A.: *Application of two-phase ejector as second stage compressor in refrigeration cycles*. 7th World Conf. on Experimental Heat Transfer, Fluid Mechanics and Thermodynamics, Kraków 2009.
- [3] BUTRYMOWICZ D., KARWACKI J., TRELA M.: *The application of two-phase ejectors*. Proceedings of XXXIII Refrigeration's Conference, Poznań 2001.
- [4] KOZIOŁ J., SKŁADZIEŃ J., GAZDA W.: *Measurement identification and comparative thermal analysis of transcritical CO₂ cycles with two-phase ejector for heat pump units*. Presentation of the Workshop meeting, SINEF – Trondheim, May 2010.
- [5] KOZIOŁ J., HAFNER A., WILŻYŃSKI Ł.: *Theoretical-empirical characteristic of ejector as an element of the transcritical R 744 cycle of heat pump unit* (unpublished).
- [6] DAQING LI, GROLL E.A: *Transcritical CO₂ refrigeration cycle with ejector-expansion device*. International Journal of Refrigeration **28**(2005) 766–773.
- [7] JIAN-QIANG DENG, PEI-XUE JIANG, TAO LU, WEI LU: *Particular characteristics of transcritical CO₂ refrigeration cycle with an ejector*. Applied Thermal Engineering **27**(2007), 381–388.