

NOWE MOŻLIWOŚCI OSZCZĘDZANIA ENERGII LOKOMOTYW NEW LOCOMOTIVE ENERGY MANAGEMENT SYSTEMS

W artykule zostały przeanalizowane nowe możliwości oszczędzania energii lokomotyw. Autor rozpatruje możliwości rekuperacji energii pociągów z napędem elektrycznym do sieci kontaktowej przy dużych szybkościach i gromadzenia energii przy małych szybkościach. Przedstawione są propozycje wariantów struktury lokomotyw hybrydowych z zastosowaniem tendera, w którym znajdują się baterie. Zgromadzona w tych bateriach energia może być w dalszym ciągu wykorzystana do trakcji, oświetlenia, klimatyzacji, itd. Przedstawiono schematy, diagramy, wykresy charakteryzujące możliwości rekuperacyjnego hamowania.

Słowa kluczowe: możliwości rekuperacji energii pociągów, struktura lokomotyw hybrydowych, tender, sieć kontaktowa.

Economic indicators of electrodynamic braking have not been properly estimated. Vehicles with alternative power trains are transitional stage between development of pollution – free vehicles. According to these aspects the investigation on conventional hybrids drives and their control system is carried out in the article. The equation that allow evaluating effectiveness of regenerative braking for different variants of hybrid drive are given. Presenting different type locomotive energy savings power systems, which are using regenerative braking energy any form of hybrid traction vehicles systems, circuit diagrams, electrical parameters curves.

Keywords: locomotive regenerative braking possibilities, hybrid technology locomotive structure, tender, catenary

1. Introduction

Different evaluations vehicles type 20–40 % of mechanical tractive power is lost during braking. Estimation of recovered energy is very important [3,4,5]. When a vehicle brake, energy is released to date, most of this energy has been lost in air. The challenging alternative is to store the braking energy on the train use it during acceleration of operation of the vehicle. Conventional diesel locomotives powered electrical transmission cannot use regenerative brake energy. High interest and the onrush of hybrid vehicle are conditioned by a number of hybrid drive advantages: decreasing of fuel consumption and of exhaust emissions; possibility of breaking energy regeneration; possibility of using in hybrid vehicles with decreased volume preserving dynamic characteristics; increasing of efficiency coefficient due to serial and multiple energy conversion; high percentage of recovered energy. Estimation of recovered energy is very important. It is needed to reduce electric demand, it is used new energy savings and power supply optimization, hybrid traction vehicles systems, which are using regenerative braking energy.

2. Locomotive energy savings systems

For the time being locomotives new energy [2,7] savings technologies include: 1 – optimized desing vehicle; 2 – energy management control system; 3 – energy storage system; 4 – low energy climate system; 5 – clean diesel motor power pack; 6 – new technogies traction motor. Energy savings up to 8–15 % using aeroefficient otimized train, up to 10–15 % using energy management control system, up to 25–30 % using energy storage system, up to 25–30 % using low energy climate system. Clean diesel motor power pack reduced particle emission 70–80 %. New

technologies traction motor increased energy efficiency 2–4 % at reduced volume and weight. New technogies can create energy savings up to 50 %. Figure 1 shows new energy savings technogies possibilities.

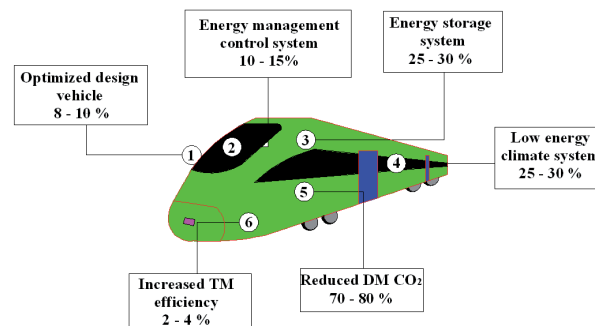

Fig. 1. Circuit diagram of locomotive energy savings structure

3. New locomotives regenerative braking possibilities

Locomotive electric braking system may be divided into dynamic, and regenerative [1]. The energy generated in the dynamic braking mode is typically transferred to resistans girds mounted on the locomotive housing. Thus, the dynamic braking energy is converted to heat and dissipated from the system. In other words, electric energy generated in the typically wasted. In a typical prior art AC locomotive, however, the dynamic braking grids are connected to the DC traction bus because eath traction grids is normally connected to the bus by way of autonomous inverter. Figure 2 shows that conventional structures electric locomotive AC traction energy transformed in to heat through a braking resistor – R_b or returned to the energy supply.

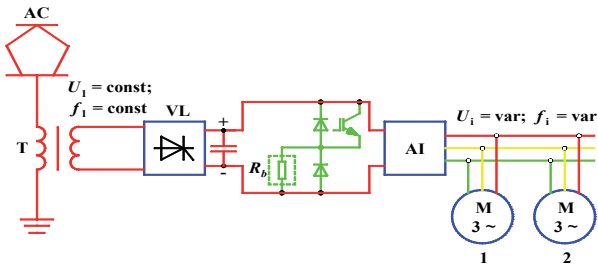

Fig. 2. Circuit diagram of AC/AC conventional electric locomotive dynamic braking: VL – controlled rectifier; AI – autonomous inverter; R_b – braking resistor; M – asynchronous traction motor

Regenerative braking is more energy effective because power given to catenary power system is either used by another electric train or returned to power system. Thus, the conditions for the motor at idle to exceed point n_0 of torque-speed characteristic $n = f(M)$, which is required in regenerative braking, cannot be satisfied (see Fig. 3). Locomotive traction motor regenerative braking energy is possible returned in to energy supply system then AC traction motor's speed is above no-load speed n_0 . The traction motor goes to the generator mode, while electromagnetic moment, becomes a braking moment, and the power produced by generator is given to the catenary (energy power supply system).

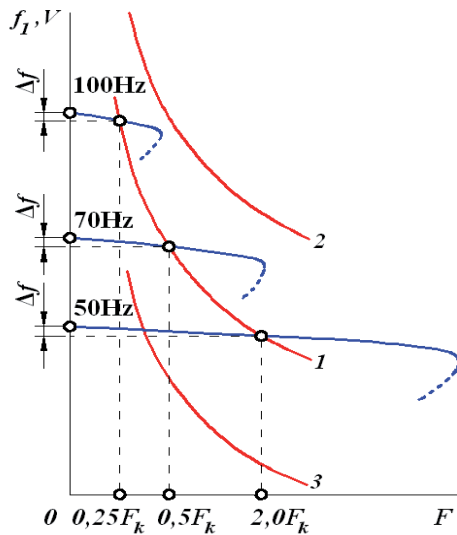

Fig. 3. Torque-speed characteristic of induction traction motor's traction modes by changing mains frequency $f_1 - f_1$ - parameters

4. Optimal asynchronous traction motor speed control

The most modern kind of speed control of three-phase induction motors is the control by changing frequency f_1 . It ensures a wide control of range of the speed and causes only little additional losses.

Relative slip expressed by the formula:

$$s = \frac{n_1 - n_2}{n_1} \quad (1)$$

where n_1 – the speed of the rotary field; n_2 – speed of the rotor (rotor speed on load).

f_1 – mains frequency is: $f_1 = \frac{pn_1}{60}$, f_2 – frequency of the rotor voltage, $f_2 = \frac{pn_2}{60}$ (there p – is number of pole pairs). Then:

$$s = \frac{f_1 - f_2}{f_1} \quad (2)$$

Asynchronous motors rotor speed:

$$n_2 = n_1(1-s) = \frac{60f_1}{p}(1-s) \quad (3)$$

may be adjusted in the following ways: by adjusting supply voltage U_1 ; by adjusting mains frequency f_1 ; by varying the number of pole pairs – p , speed of the of the rotor's rotating field can be discretely changed; by adjusting slip s (not using slip energy), the nature of the speed-torque characteristic can be changed; by adjusting slip s (using a part of slip energy – cascade speed control circuits of asynchronous motors). Asynchronous motors with squirrel-cage rotors and their parameters expressed by the formula:

$$M = \frac{p_1 m_1 U_1^2 \frac{f_1}{s}}{2\pi f_1 \left(r_2' + \frac{r_1}{s} \right) + (x_1 + x_2')} \quad (4)$$

where p_1 and m_1 – are numbers of the stator's poles and phases; r_1 and x_1 – denote resistance and inductive impedance of stator; r_2' and x_2' – denote resistance and inductive impedance of rotor reduced in accordance with the stator's parameters; U_1 – is supply voltage of the stators windings.

Optimal mode of operation of asynchronous motors with squirrel-cage rotors [5]:

$$\frac{U_1}{U_1'} = \frac{f_1}{f_1'} \sqrt{\frac{M_1}{M_1'}} \quad (5)$$

Hence, an optimal mode of operation of asynchronous motors with squirrel-cage rotors is defined by the relationship between their three parameters – amplitude of voltage U_1 , frequency f_1 and the developed torque M_1 . A mode of operation of a locomotive can be described by the locomotive speed V and traction or braking force F_k of wheel-set. It was found that:

$$V = 0,188 \frac{D}{\mu} \frac{60f_1}{p}(1-s) \quad \text{or} \quad V = 0,188 \frac{D}{\mu} \frac{60f_1}{p} = C_1 f_1, \quad \text{and}$$

$$F_k = \frac{2M}{D} \mu \eta_p = C_2 M \quad (\text{here: } D - \text{ is diameter of the locomotive}$$

wheel-set; μ – is gear ratio; η_p – is gear efficiency). On the basis of the formula (6), we can determine mode control of locomotives with asynchronous motors:

$$\frac{U_1}{U_1'} = \frac{V_1}{V_1'} \sqrt{\frac{M_1}{M_1'}} \quad \text{or} \quad \frac{U_1}{U_1'} = \frac{V_1}{V_1'} \sqrt{\frac{F_k}{F_k'}} \quad (6)$$

In this case, speed V_1 and traction or braking force F_1 correspond frequency f_1 , and supply U_1 , or V_1' and F_k' – traction or braking force in presence of frequency f_1' and voltage U_1' .

When the supply voltage voltage increased, the characteristics move the area of higher speed (Fig. 3, line 2). By changing simultaneously the supply voltage U_1 and its frequency f_1 , depending on mode regulation, any flat characteristics can be obtained.

The frequency controlled squirrel-cage induction motor can be easily showed down by reducing the supply frequency. If, by

that, the motor is drive by the load, it changes to the generator operation and begins to feed back energy. This energy must by either fed back into three-phase supply network or transformed into head trough a braking resistor.

When the AC traction motor load moment changes the speed n of the AC traction motor rotor speed exceeds n_0 , the traction motor goes to the generator mode, while electromagnetic braking moment is developed. Traction motor's no-load speed n_0 is possible by changing the frequency f_1 and to receive more regenerative braking characteristics and regenerative braking energy returned to network supply or charging storage battery. Figure 4 shows AC traction motors operate new possibilities traction and regenerative braking mode.

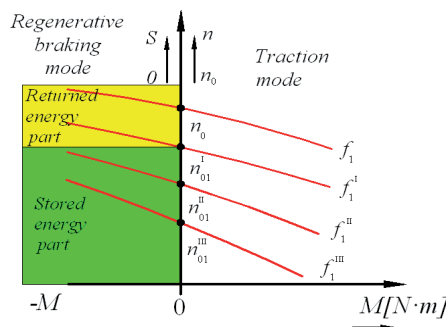

Fig. 4. Torque-speed characteristic of induction traction motor's regenerative braking and traction modes by changing mains frequency $f_1 - f_i$ - parameters: $n_{01} - n_{0i}$ is AC traction motor's no-load speed

Authors suggested in to conventional electric locomotive to install storage battery. Figure 5 shows principle of the braking energy management system used AC/AC electric locomotive, when part of regenerative braking energy returned in to energy supply system and part of energy stored storage battery.

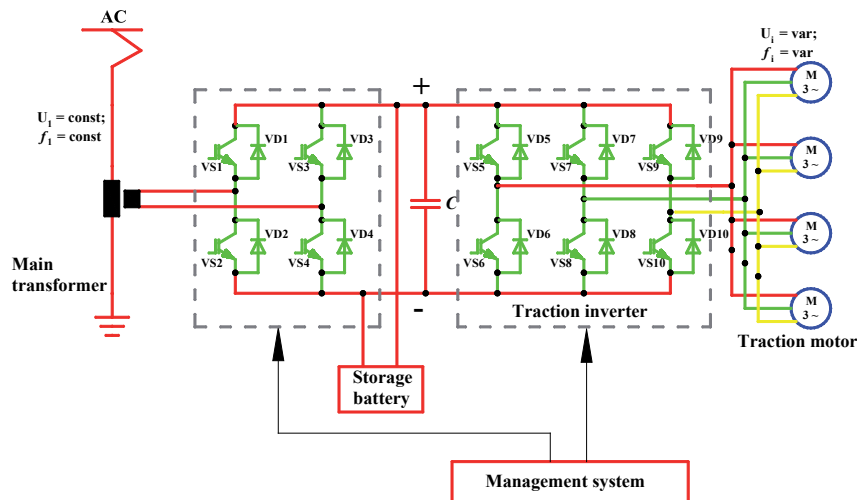

Fig. 5. Circuit diagram of AC/AC electric locomotive regenerative braking energy management system

5. Hybrid traction propulsion system

Hybrid traction energy saving propulsion system using storage-battery technology. As the train using its traction motors the authors suggest use a hybrid propulsion system combining an engine generator with storage batteries. A hybrid energy loco-

otive system having an energy storage and regeneration system. The traction batteries store the regenerated electrical power that would have otherwise been wasted in heat using friction/dynamic braking. Using regenerative braking, fuel consumption is minimized. Peak levels of energy efficiency are regulated by the energy management system. The energy storage and regeneration system captures dynamic braking energy, excess motor energy, and externally supplied energy, and stores the energy in one or more energy storage subsystem, including a flywheel, a battery, an ultra - capacitor, or combination of such subsystems. The energy storage and regeneration system can be located in a separate energy tender vehicle. The energy management system controls the storage and regeneration of energy accordingly. Any recovered energy can be used for traction. This system provides regenerative braking not previously possible on conventional diesel-powered trains, and this makes it possible to increase energy savings via regenerated energy. In one form, the system can be retrofitted into existing locomotives or installed as original equipment. We are offering to use a hybrid traction technology. Conventional diesel locomotives powered electrical transmission can not use regenerative braking energy. As the train using its traction motors, the storage batteries store the regenerated electrical power that would have otherwise been wasted in heat using friction/dynamic braking. Using regenerative braking, fuel consumption is minimized. Peak levels of energy efficiency are regulated by the energy management system. Any recovered energy can be used for traction.

This is expected to give fuel savings of approximately 20–25 % compared with conventional diesel-powered trains. This system uses a series-hybrid configuration (see Fig. 6) that first converts the engine output into electrical power and then uses only motors for propulsion. Diesel engine energy is converted by the synchronous traction alternator (generator – GS). The AC (alternating current) output generated by the engine is converted into a VVVF (variable voltage variable frequency converter). Storage

batteries are located on the intermediate DC section of the main converter. The charging and discharging of the storage batteries are controlled using output adjustments of the converter and inverter. Storage batteries charging and discharging processes are controlled of the converter and inverter output for management

system. When using DC traction motors, output of the alternator is typically rectified to provide appropriate DC power. When using AC traction motors, the alternator output is typically rectified to DC and traction inverter inverted to three-phase AC before being supplied to traction motors. Under braking, the engine is stopped. The traction motors act as generators, and recovered energy is used to charge the batteries. Storage battery operation of charging mode.

Upon departure, the train accelerates using recovered energy only. Storage battery is operation of discharging mode.

Authors suggested to use externally supplied energy system with energy tender.

Timing diagram is illustrating locomotive energy management system, traction and regenerative braking mode. Timing diagram illustrating the hybrid traction system energy storage possibilities: $0 - t_1, t_2 - t_3$ – time cycles of using powered storage energy traction and auxiliary equipment mode; $t_1 - t_2$ time cycles of stored energy mode.

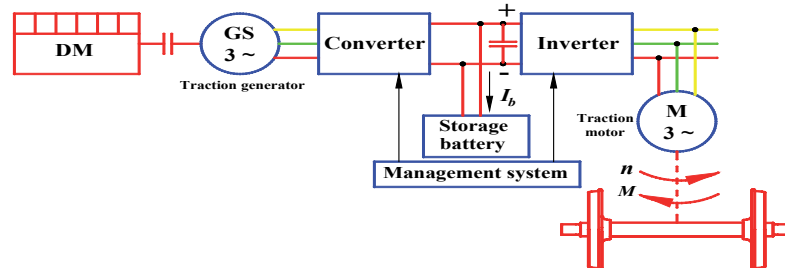

Fig. 6. A circuit diagram of hybrid traction system (regenerative braking mode): DM – diesel engine; G – synchronous traction alternator (generator); I_b – regenerative braking current; SB – storage battery; M – induction traction motor

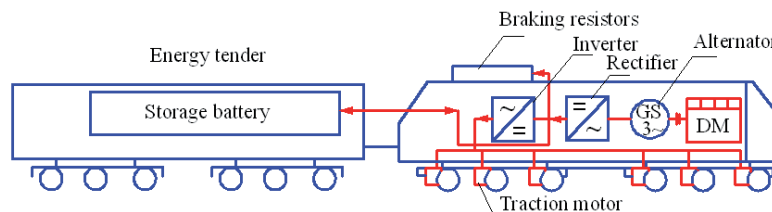

Fig. 7. Circuit diagram of hybrid energy traction system using energy tender vehicle

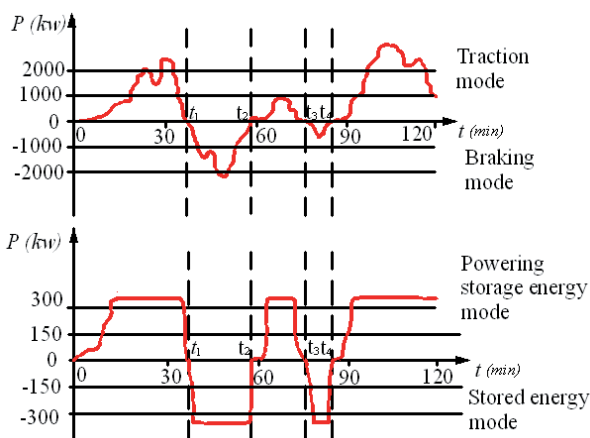

Fig. 8. Timing diagram of hybrid energy traction system using energy tender vehicle

6. Energy savings and power supply optimization possibilities

The most challenging operating for storage devices on board of traction vehicle are high number of load cycles during the vehicle lifetime, relatively short charge and discharge times as well as high charge and discharge power values. In contrast to high-maintenance, flywheel based, mechanical energy storage used in vehicles. Energy savings and power supply optimization system operates on purely electrical basis. The battery will be charging when line voltage tends to go up so that it limits the line voltage increase. Regenerative braking energy is normally limited, when the line voltage goes up to a limit. Trains can unlimitedly generate regenerative braking energy when capacitors (see Fig. 10) conventional store batteries CCSB operated. The regenerative braking energy is consumed by the train itself and by other powering trains. Excessive power will be stored in the battery. The charging voltage at the batteries is higher than that of the substation. It is considered that all charged energy come from the regenerative braking.



Fig. 9. High-performance double layer technology capacitor (ultra capacitor)

The innovative double layer ultra capacitors store the energy released each time a vehicle brakes and reduced it during acceleration or operation. Energy savings (optimization) system where is used conventional storage battery which capacitor is offered (see Fig. 10).

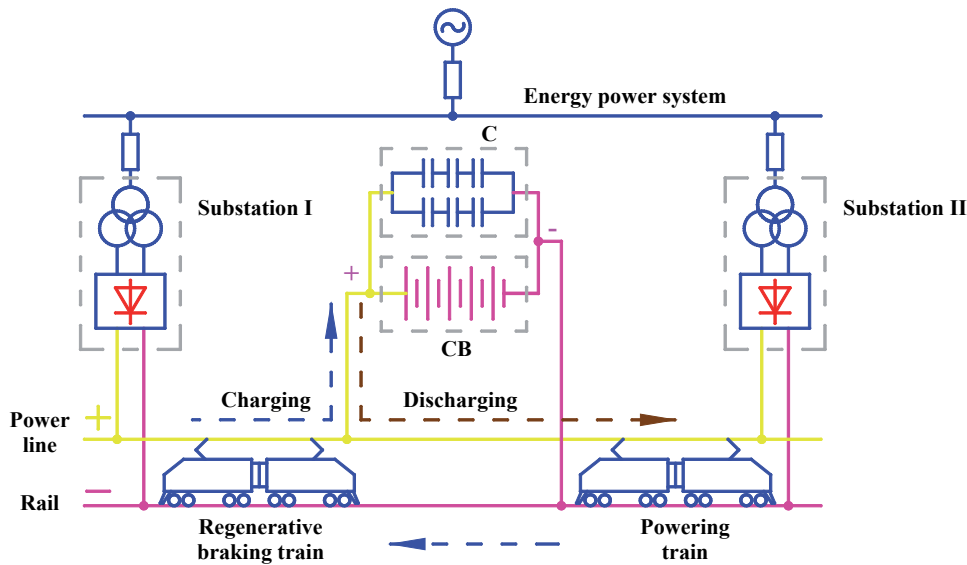

Fig. 10. A circuit diagram of using regenerative braking returning energy: C – capacitors; CB – conventional batteries

Prevent losing effect of regenerative braking energy with limited line voltage drop. Regenerative braking energy will lose its effect when the line voltage goes up to 900 V (when nominal 750 V) and when substations operated with no batteries. The CCSB enables to limit the voltage increase when charging. In case of our proof test, line was 830 V when the CCSB operated so that it could prevent losing regenerative braking energy. When powered trains are congested at rush hours, since the line voltage tends to drop, the batteries discharge to make voltage balance between those of the CCSB and the substation. Receiving electricity can be reduced around 110 kW when battery/substation is connected by parallel operation, and 175 kW when the CCSB is operating (see Fig. 10) by itself. Prevent line voltage drop with discharging batteries. The lowest voltage of the power line was up to 680 V from when the CCSB operated. The new technical solution is used by conventional batteries with high-performance double layer capacitors (ultra-capacitors). Energy-saving system can be used when provides vehicles with an energy source that allows frequent starting and braking. The system works by charging up these storage devices with electrical energy released when braking. This stored energy can be used in many ways. Energy-saving system can be used in conjunction with any traction converter. Energy savings and power supply optimization system can be reduced the energy consumption of a light rail or metro system by up to 30 percent. Using power supply optimization system for diesel multiple units allows energy savings can be even up to 35 percent. Alternatively, the stored energy can be used as performance booster: enhances the performance of vehicle by adding extra power during acceleration.

7. Vehicle Catenary – Free Operation

In addition to these well – known factors, municipal authorities are increasingly facing visual pollution caused by power poles and overhead lines obstructing the visibility of landmark buildings and squares. With catenary – free operation trams can even run through heritage – protected areas, such as parks and gardens, historic market and cathedral squares, where conventional catenary systems are not permitted, thus preserving natu-

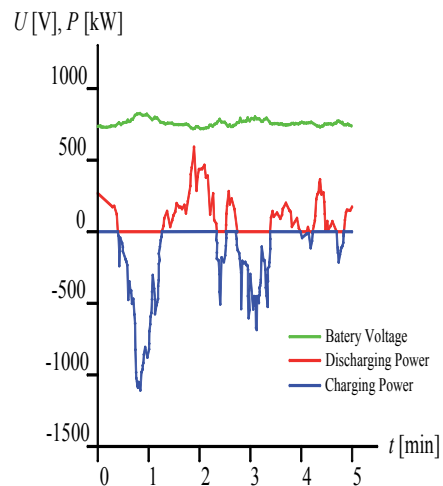

Fig. 11. A capacitors-conventional store batteries CCSB parameters curves: charging (regenerative braking) and discharging (acceleration) mode, battery voltage

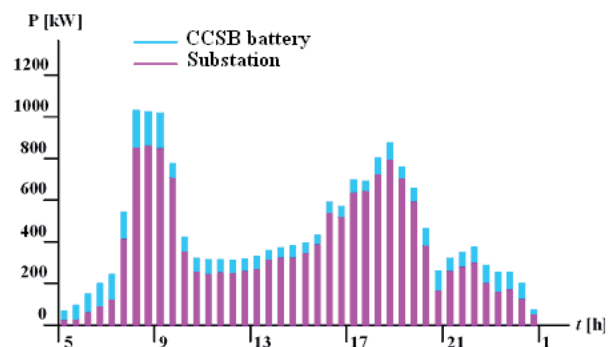

Fig. 12. Reduced electric power demand, when capacitors-conventional store batteries CCSB parallel connected with substation

ral and historic environments. Authors suggest use catenary free system for trams, light rail vehicles, trolleybuses. In many city centre overhead lines and their surrounding infrastructure contri-

bute to visual pollution of historic streets, parks or architectural landmarks. Catenary – free tracks for trams and light rail vehicles heighten the attractiveness of a city and provide for unobstructed views. The new system allows catenary – free operation of trams over distances of varying lengths and in all surroundings as well as on underground lines – just like any conventional system with overhead lines. Catenary – free system traction inverter is connected to the storage battery. Storage battery is charging during vehicle traction motor operation in regenerative braking mode and discharging as traction motor operation in traction mode, there conventional energy lines is discontinued. Energy saver, which stores electrical energy that is gained during operation and braking on board the vehicle by using high – performance double layer capacitor technology. Doing so optimizes power supply and saves energy. How does the catenary free operation system work? When running on conventional system, trams and light rail vehicles take energy from an overhead electrical line. The authors suggest to install to the vehicle (inside or outside) storage battery (ultra-capacitors block) which store the energy gained during regenerative braking operation and is constantly charged up, either when the vehicle is in motion or waiting at a stop, picking up the power from the storage battery. Fig. 13–16 shows vehicle configuration and catenary free operation possibilities. Catenary free operation necessary power provided from the battery.

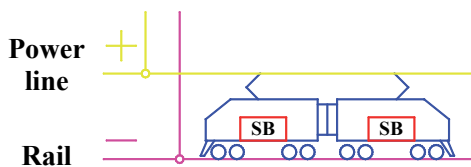

Fig. 13. A circuit diagram of the vehicle configuration: SB- storage battery

formance than conventional batteries. High-performance storage cells are connected in series to create a storage unit. They store the electrical brake energy with relatively low losses.

7. Hybrid locomotive energy balance

Within the bounds of the present research the question of qualitative evaluation of regenerative power during hybrid vehicle braking is of fundamental importance.

Vehicle power during braking on horizontal road P_{br} can be expressed by the following equation:

$$P_{br} = k_m \cdot m \cdot a \cdot V \quad (7)$$

where: k_m – coefficient of rotational masses; m – vehicle mass; a – vehicle acceleration (deceleration); V – vehicle velocity.

The power, that can be received during regenerative braking is:

$$P_{regen} = k_m \cdot m \cdot a \cdot V \cdot \eta_{regen} \quad (8)$$

where: k_m – coefficient of rotational masses; m – vehicle mass; a – vehicle acceleration (deceleration); V – vehicle velocity; η_{regen} – efficiency of regenerative braking (can be defined as rate of energy, received during braking up to decrease of vehicle kinetic energy).

At the same time, regenerative braking power can be considered as electric power, that finally receives the storage element (in this case storage battery):

$$P_{regen} = P_{el} = I_{bat} \cdot U_{bat} \quad (9)$$

where: P_{el} – electric power that receives battery; I_{bat} – battery current; U_{bat} – battery voltage.

The effectiveness of regenerative braking can be estimated using these equations:

$$\eta_{regen} = \frac{P_{regen}}{P_{br}} = \frac{I_{bat} \cdot U_{bat}}{k_m \cdot m \cdot a \cdot V} \quad (10)$$

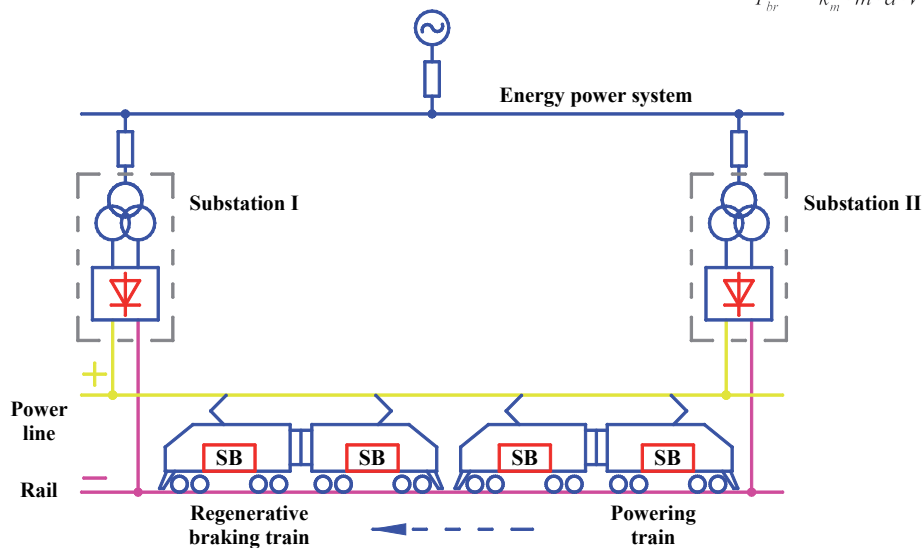

Fig. 14. A circuit diagram the electric train configuration: then is possible to regenerative braking energy returning to the energy network or stored using storage battery: SB – storage battery

The innovative double layer ultra – capacitors store the energy released each time a vehicle brakes and reduce it during acceleration or operation. New technical solution is based on double layer capacitors with along service life and ten times higher per-

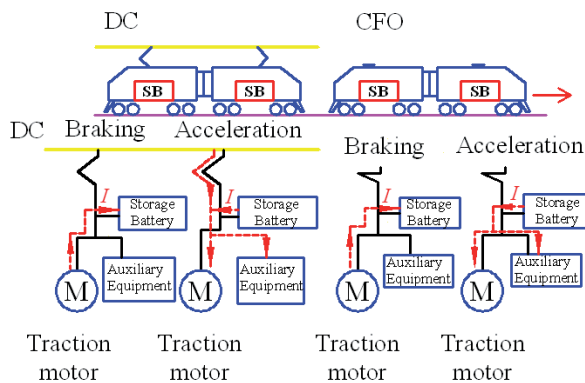

Fig. 15. Vehicle catenary free operation: DC – catenary system; CFO – catenary free operation

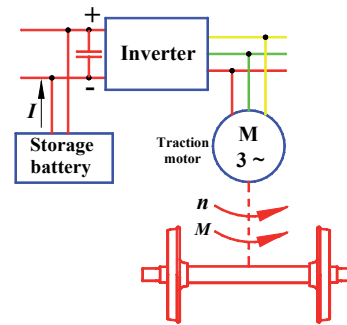

Fig. 16. A circuit diagram of the vehicle catenary free operation (traction mode)

8. Conclusions

1. Electrodynamic braking is the main braking technique used for modern electrically-driven locomotives.
2. Electric locomotives use regenerative braking of high-speed trains under the conditions of heavy railway traffic allows 25–40 % of electric power to be returned to the power system. The required regenerative braking forces can be obtained in a wide range, with possibilities returned energy to energy supply in a high-speed range and stored energy-in a low-speed range.
3. All diesel electric powered locomotives must use hybrid traction technology.
4. Hybrid traction technology locomotives can be use regenerative braking of high-speed and a low-speed range.
5. Hybrid traction technology locomotives are reducing 25–30 % energy.

9. References

1. Braess, H. H., Seiffert U. Vieweg Handbuch Kraftfahrzeugtechnik. Friedrich Vieweg & Sohn Verlagsgesellschaft GmbH, Wiesbaden, 2000.
2. Inarida S. et al. Train Traction Systems for Passenger Comfort and Easier Maintenance, Hitachi Review 50, 2001, p. 134–138.
3. Liudvinavičius L., Lingaitis L. P: Electrodynamic braking in high-speed rail transport. Transport 2007; 22(3): 178–186.
4. Lingaitis L. P., Liudvinavičius L. Electric drives of traction rolling stocks with AC motors. Transport 2006; 21(3): 223–229.
5. Strekopytov V. V., Grishchenko A. B., Kruchek V. A. Electric drives of the locomotives. Moscow: Marshrut, 2003.
6. Takashi Kaneko et al. Easy Maintenance and Environmentally-friendly Train Traction System Hitachi Review 2004; 53(1): 17–19.
7. Yamaguchi J. Blue skies at Makuhari. Automotive Engineering International 2006; 1: 55–62.

6. The regulation algorithm offered allows us to obtain various type of flat characteristics enabling asynchronous traction motor to be extensively used in traction, recuperation and dynamic braking modes of operation.
7. A circuit scheme of using hybrid traction technology with energy storage tender and catenary-free operation is offering.
8. The regenerative braking power it possible use in diesel electric locomotives for starting engine, acceleration, and operation mode.
9. The power stored in the locomotive in traction is completely utilized. When ordinary mechanical braking is applied, no useful work is done by the power and it is not used in braking.
10. Energy savings and power supply optimization possibilities is offering.

Mgr. inž. Lionginas Liudvinavičius
Prof. Leonas Povilas Lingaitis

Dept of Railway Transport
 Vilnius Gediminas Technical University
 J. Basanavičiaus g. 28,
 LT-03224 Vilnius, Lithuania
 e-mails: liong@ti.vgtu.lt; leonasl@ti.vtu.lt