

Rotor Power Loss in a PM SM by Calculation, Simulation and Measurements, Mutual Verification of Methods

Jean Claude VANNIER¹⁾, Robert KACZMAREK¹⁾,
Zhu-Yun WANG¹⁾, Andry RANDRIA²⁾

1) Supélec, France, 2) Alstom, France

Summary: The subject of the paper is the comparison of four complementary methods of the rotor loss estimation in a PM SM, supplied by a PWM voltage source. An ANSYS based finite element model produces values of W , the magnetic energy stored, and P , the rotor losses. On analytical level the machine is represented by a parallel two elements equivalent circuit for each voltage harmonic. Its parameters are estimated using P and W values. Finally, the eddy current losses representation in the ANSYS code is verified for magnets under study by direct losses measurements. The calculation results are compared with some measured values resulting from analysis and harmonic decomposition of the machine total losses.

Key words:
synchronous machine,
permanent magnet,
eddy current loss,
equivalent circuit

1. INTRODUCTION

The design of electrical machines is a matter of several complementary approaches, as no single method is able to produce a satisfactory explanation of the system's behaviour. For example, the finite element software permits the precise field calculation, but the lack of effective moving-boundary FE package incites studies with space harmonics limited to the fundamental one and the rotor at standstill [1], which does not correspond exactly to an actual machine conditions. On the other hand, if the FE calculated space distributions can be controlled to a high level of precision, their practical exploitation depends on parameters' values or on adopted formulae as well. These to be effective, a pertinent range of parameters should first be determined.

Here the analytical approach can be useful, providing the designer with some qualitative indications. Nowadays, solving the field equations leads to a good knowledge of field distribution. A sensitivity analysis for several parameters' values shows, for example [2], that the influence of stator slotting decays quickly with distance from the stator core.

The simulation and analysis can be verified by measurements not only at the final stage of overall system's performances, but also with specific questions, like the basic laws of magnetic losses in systems being well described by the FE calculated field distribution.

We have tried such a multiple approach [3] to evaluate the magnetic losses in the surface mounted permanent magnet synchronous machine supplied by a PWM voltage source.

2. ANALYTICAL MODEL

An analysis of the machine under study proves [4] an essentially sinusoidal space disposition of the stator magneto-motive force mmf. The higher order space harmonics are strongly attenuated through the coils arrangement. On the other hand the associated field time harmonics rotate at a

relatively low speed in the rotor reference frame. In the time domain only harmonics $k = 5, 7, 11$ and 13 should be accounted for. They generate non negligible eddy currents in the rotor's magnets, as they rotate at rather high angular velocities of $-6\Omega, 6\Omega, -12\Omega$ and 12Ω in relation to the rotor.

Under assumptions that the machine is magnetically not saturated and that the eddy currents in magnets are the magnet's only dissipative phenomena we can admit the principle of superposition of harmonic fluxes, each one of them generating in magnets the corresponding eddy currents.

Then a study of a simple equivalent circuit for each harmonic of order k can be tempted, representing the machine steady state harmonic response, i.e. the magnetic energy stored in an inductance L_k and the dominant losses dissipated in a loss resistance R_k . For a voltage supplied machine this will be a two element parallel circuit (Fig. 1) under harmonic voltage V_k .

In case of large PM SM, with stator laminated, coils resistance negligible and good quality of stator and rotor iron, we can take the circuit as representing the stator coils magnetic energy and the rotor PM magnetic losses.

This circuit can be identified as a part of the Park transform extension for surface-mounted permanent magnet synchronous motors in rotor domain (Equ. 1)

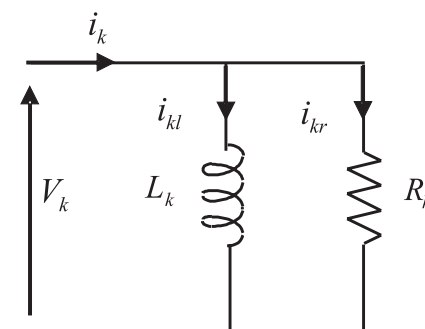

Fig. 1. An equivalent harmonic model of a PM SM

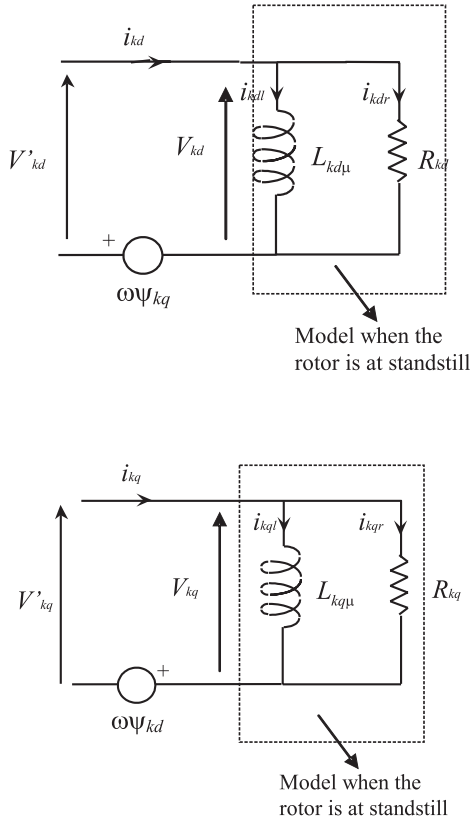

Fig. 2. The surface mounted PM SM Park transform extension

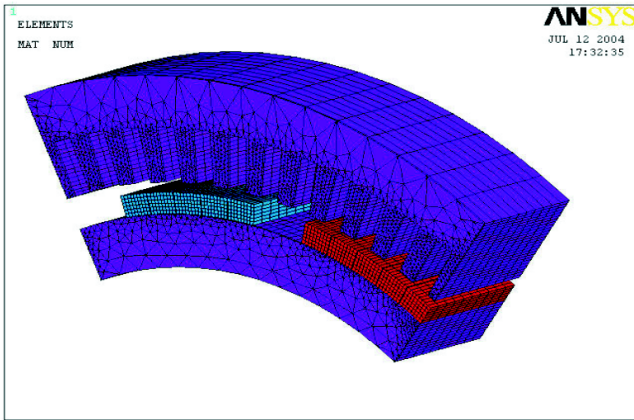

Fig. 3. Finite element model 3D

$$V'_{kd} = \frac{d\psi_{kd}}{dt} - \psi_{kq}\omega$$

$$V'_{kq} = \frac{d\psi_{kq}}{dt} + \psi_{kd}\omega$$

The rotor anisotropy is represented with different losses resistances added in parallel and the rotational voltage present (Fig. 2) in d - q co-ordinate system rotating in step with the rotor flux at electrical velocity $\omega = d\theta/dt$.

In the expressions above the indexed voltages V'_{kd}, V'_{kq} concern the stator windings and include the corresponding components $\omega\varphi_{kd}$ and $\omega\varphi_{kq}$ involving the

machine fundamental electrical speed ω , whereas the voltages applied to the d - q model at standstill are V_{kd}, V_{kq} . The latter generate harmonic flux rotating at the speed ω_k in relation to immobile rotor and creating the eddy currents.

Using the complex plane representation:

$$\bar{i}_k = i_{kd} + j i_{kq}$$

$$\bar{V}'_k = V'_{kd} + j V'_{kq} \quad (1)$$

$$\bar{\psi}_k = \psi_{kd} + j \psi_{kq}$$

we get for the Park transform (1) a complex form:

$$\bar{V}'_k = \frac{d\bar{\psi}_k}{dt} + j\omega \bar{\psi}_k = j(\omega_k + \omega)\bar{\psi}_k \quad (2)$$

and for \bar{V}_k we have:

$$\bar{V}_k = \frac{d\bar{\psi}_k}{dt} = j\omega_k \bar{\psi}_k \quad (3)$$

The relation between \bar{V}'_k and \bar{V}_k can be written as:

$$\bar{V}_k = \left| \frac{\omega_k}{\omega_k + \omega} \right| \bar{V}'_k$$

At load the actual d - q harmonic voltages V'_k differ from the standstill voltages V_k by $\pm \omega\Psi$, so that for amplitudes we have:

$$\bar{V}_k = \frac{6m}{6m-1} \bar{V}'_k \quad \text{for } 5^{\text{th}}, 11^{\text{th}} \dots,$$

and:

$$\bar{V}_k = \frac{6m}{6m+1} \bar{V}'_k \quad \text{for } 7^{\text{th}}, 13^{\text{th}} \dots$$

When assuming identical parameter values in both d and q axes, the parallel circuit represents one of two identical Park models of the machine at standstill. Then for each harmonic the average energy and loss values are:

$$\langle W \rangle = \frac{1}{2} L_k \hat{I}_{kl}^2 \quad \langle P \rangle = R_k \hat{I}_{kr}^2 \quad (4)$$

with an additional information on current I_k feeding it:

$$I_k^2 = I_{kL}^2 + I_{kR}^2$$

In order to evaluate L and R we have to know currents, energy and losses. This will come with the FE simulation.

3. FINITE ELEMENTS SUPPORTING THE PARALLEL CIRCUIT

In the FE modelling, the rotor is at standstill and equivalent travelling current sheet rotates around it. These are conditions of the parallel analytical model if it is supplied by previously measured voltage harmonics adapted to this configuration.

Then, for each harmonic, the parallel circuit's parameters R and L can be estimated by the FE based calculation of the stator coils magnetic energy W and of the rotor PM magnetic losses.

The calculation have been first established on a 2D FE model, taking one pair of poles in tangential direction and one segment length of the magnet in the axial direction, and then extruded to a 3D model (Fig. 3) with a three phase current harmonics injected into slots, the -6ω , $+6\omega$, -12ω and $+12\omega$ for, respectively, the 5th, 7th, 11th and the 13th stator time harmonics.

Thus the equivalent circuit's elements can be identified for a given rotor topology at several harmonics permitting easy extension of frequency characteristics which disclose tendencies to be reckoned with Figures 4 and 5.

The losses in the ANSYS FE package being calculated as eddy current in volume $P_v = \rho j^2(t, x, y, z)$, the question arises on the pertinence of this formula in specific SmCo 2-17 magnets under study. A confirmation may be expected by measurements on magnet specimen, if only we find losses as proportional to $B^2 f^2$ in response to a harmonic excitation.

4. MAGNETIC SPECIMEN MEASUREMENT AND SIMULATION

The benchmark is a no-load transformer in form of a symmetrical laminated U circuit with magnets located in air-gaps. With the U-iron losses negligible, the flux in the magnets as well as the flux dispersion are evaluated with aid of measured input current and voltage as well as the open voltage in magnets area (Fig. 6).

The measurements having been repeated and the results averaged we have found the smaller magnets' losses better approaching the $B^2 f^2$ law (Table 1).

The benchmark has then been modelled in ANSYS with one quarter of the circuit represented in 3D code, which permits to take into account the magnet's reaction, which is visualized on Figure 7.

In the case of "large magnets" the losses law simulated has been found:

$$P \propto f^{1.64} B^{2.1}$$

to be compared with the benchmark-based values:

$$P \propto f^{1.68} B^{2.07}$$

The machine simulation and the measurements on specimen produce close results, witnessing the same distortion on the $B^2 f^2$ law. The exponents dispersion relative to the basic ANSYS rule $P_v = \rho j^2(t, x, y, z)$ may perhaps be explained by magnet's reaction reducing the excitation field, or by imprecision of parameters' values, like magnet's resistivity.

Table 1. Power indices for the losses law in magnet specimen.

	α	β
Large magnet	1.68	2.07
Small magnet	1.98	1.92

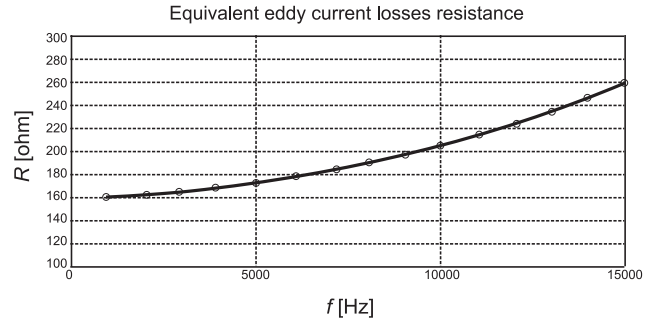

Fig. 4. An example of equivalent rotor resistance

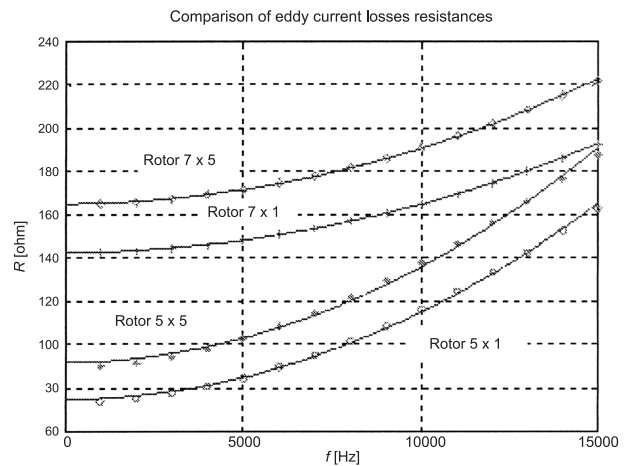

Fig. 5. Loss resistance for different rotor types, an industrial study

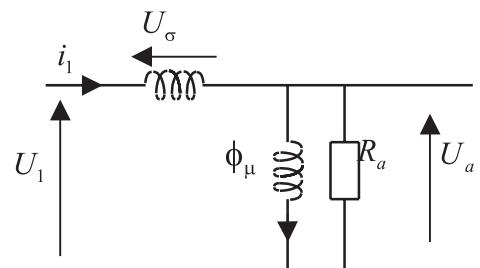

Fig. 6. Vector diagram to loss evaluation

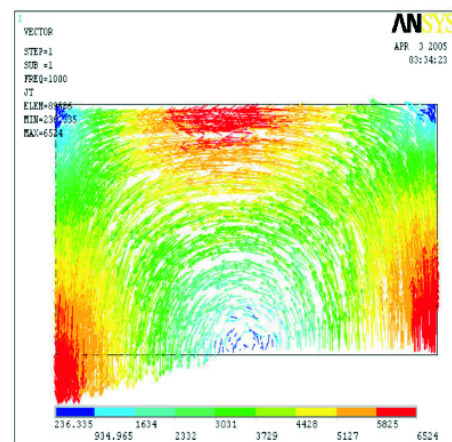

Fig. 7. FE simulated eddy currents in half a magnet under excitation

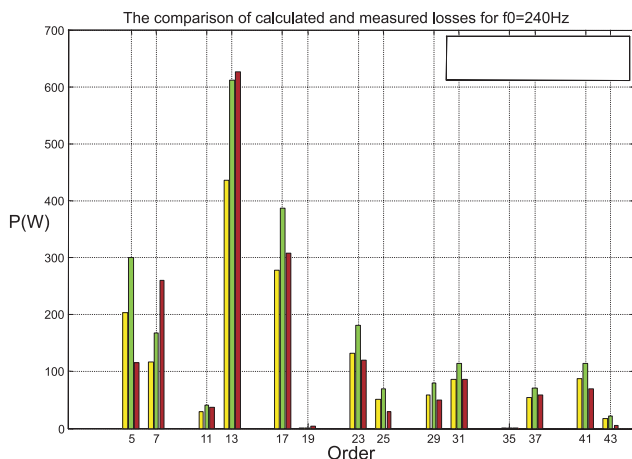

Fig. 8. Left to right: calculated rotor and total losses, measured total losses

Nevertheless, the FE simulation producing parameters values for the parallel circuit, the measurements seem to confirm them both.

5. MACHINE MEASUREMENTS AND SIMULATION

The SM measurements of harmonic voltage, current and power factor were used to identify the harmonic power losses and to isolate losses in magnets. Comparing to simulation results, a good agreement has been found except for certain harmonics; here we present (Fig. 8) an example with the 5th and the 7th harmonics deviating.

These discrepancies are boring, particularly when compared with quite a good accord of higher order harmonics. This should mainly be the problem of identification of active power components in the rotor consumed power. The simulation with rotor at standstill gives here the loss dissipation, whereas the machine measurements include the power generated by harmonics, which can be positive (for those rotating at +6kw) or negative, undistinguishable by measurements. This factor diminishes with harmonic order.

6. CONCLUSIONS

We think the equivalent circuits may be useful and the measurements necessary for efficient FE modelling. The problem here is with linking together the formal complexity of the latter with apparent simplicity of both synthesis in equivalent circuits and analysis in treatment of measurement data.

REFERENCES

1. Abu Sharkh S.M., Harris M.R. and Taghizadeh Irenji N.: *Calculation of rotor eddy current loss in high speed PM Alternators*. IEE Int Conf. Electrical Machines and Drives, 1997, Conference Publication n° 444, pp. 170–174.
2. Zhu Z.Q., Howe D., Chan C.C.: *Improved Analytical Model for Predicting the Magnetic Field Distribution in Brushless Permanent-Magnet Machines*. IEEE Trans. Magn. Vol. 18 n°1, Jan 2002, pp. 229–238.
3. Wang Z.Y.: *Analyse et mesures de pertes dans le rotor d'une machine synchrone a aimants permanents pour en optimiser la structure*. These de doctorat Paris XI-Supélec, 2005.
4. Wang Z.Y., Vannier J.C., Randria A., Kaczmarek R.: *Improvement of permanent magnet synchronous motor performances reducing the rotor losses*. All Electric Ship AES 2005, Versailles oct. 2005.



Jean-Claude Vannier

professor and Head of Department of Energy and Power Systems in the Ecole Supérieure d'Electricité (Supelec) in France. His research interest is with energy conversion systems (motors, actuators, generators) and concerns the modeling, the design and the optimization of these equipments for specific applications.

Address:

Supélec, Département Energie,
91192 Gif sur Yvette, France

E-mail: jean-claude.vannier@supelec.fr



Robert Kaczmarek

professor in the Ecole Supérieure d'Electricité (Supelec) in France. His research interest is with power networks (fault detection, network protection, parameters identification), with magnetism (domain observation, loss prediction and measurements in soft and hard magnetic materials) and design of electric machines.

Address:

Supélec, Département Energie,
91192 Gif sur Yvette, France

E-mail: robert.kaczmarek@supelec.fr



Zhu Yun WANG

born in Zhejiang, P.R. China, on June 18, 1979. He received the B.S. degree in electrical engineering from Shanghai Jiao Tong University, P.R. China, in 2001. He received the M.S. degree in electrical engineering from University Paris XI, France, in 2002. He received his PhD. in electrical engineering from "Ecole Supérieure d'Electricité (Supélec)" and University Paris XI, France, in 2005.

Address:

Supélec, Département Energie,
91192 Gif sur Yvette, France

E-mail: wangzhuyun@hotmail.com



Andry RANDRIA

Technical Project Manager in ALSTOM Transport. His research interest concerns design and validation of electric machines for Railways Applications.

Address:

Alstom
65000 Tarbes, France

E-mail: andry.randria@transport.alstom.com