

DYNAMICS OF MINEHUNTERS SHAFTS LINES

Andrzej GRZĄDZIELA

Naval University of Gdynia, Mechanical – Electrical Faculty
Ul. Śmidowicza 69, 81-103 Gdynia, Poland, e-mail: agrza@amw.gdynia.pl

Summary

Ships' propulsion plant usually works in a hard environment caused by static forces and permanent dynamic loads. Exceeding of tolerated values of shaft alignments causes a damage of radial and thrust bearings in relative short time. Modeling of dynamical reactions could bring information to the designer for recognizing the level of hazard for propulsion system. A paper presents a proposal of identification of a degree of hazard to ship shaft line due to forces of shafts misalignment. A theoretical analysis was made of influence of changes in co-axiality of shafts resulting from elastic deformations of hull structure in vicinity of shaft bearing foundations. The main problem of naval vessels is a lack of dynamical requirements of stiffness of the hull. Modelled signals were recognized within sensitive symptoms of two sub models: model of propulsion system and model of shafts misalignment. Both sub models allow testing forces and their responses in vibration spectrum using SIMULINK software.

Keywords: ship shaft lines, technical diagnostics, modelling, vibrations, underwater explosion.

DYNAMIKA LINII WAŁÓW OKRĘTÓW ZWALCZANIA MIN

Streszczenie

Jednym z podstawowych problemów w konstrukcji okrętów jest brak precyzyjnych wymagań w zakresie sztywności kadłuba. Oddziaływania dynamiczne mogą powodować elastyczne odkształcenia, które oddziałują na łożyska linii wałów. Referat prezentuje propozycję identyfikacji zagrożeń dla linii wałów okrętowych wynikających z przekroczenia parametrów współosiowości. Przedstawiono analizy teoretyczne dynamiki wału śrubowego z uwzględnieniem zagadnienia przesunięcia osi wału wynikającego z obciążeń dynamicznych kadłuba. Modelowanie reakcji dynamicznych może umożliwić budowę bazy danych dla potrzeb systemu monitoringu. Przedstawione modele wykonane w środowisku SIMULINK pozwalają testować reakcje dynamiczne spotykane w rzeczywistych warunkach eksploatacji okrętu.

Słowa kluczowe: linia wałów okrętowych, diagnostyka techniczna, modelowanie, drgania, wybuch podwodny.

1. INTRODUCTION.

Minehunters propulsion systems are subjected to specific sea loads due to waving and dynamical impacts associated with underwater explosion. Sea waving can be sufficiently exactly modeled by means of statistical methods. Much more problems arise from modeling impacts due to underwater explosion. Knowledge of a character of impulse loading which affects ship shaft line, can make it possible to identify potential failures by means of on-line vibration measuring systems.

2. ANALYSIS OF FORCES ACTING ON SHAFT-LINE BEARINGS

Ship shaft lines are subjected to loads in the form of forces and moments which generate bending, torsional and axial vibrations. In most cases strength calculations of driving shafts are carried out by using a static method as required by majority of ship classification institutions. Moreover they

require calculations of torsional vibrations which have to comply with permissible values, to be performed. Calculation procedures of ship shaft lines generally amount to determination of reduced stresses and safety factor related to tensile yield strength of material. The above mentioned methods do not model real conditions of shaft-line operation, which is confirmed by the character of ship hull response, i.e. its deformations under dynamic loads. Much more reliable would be to relate results of the calculations to fatigue strength of material instead of its yield strength [5].

In static calculation procedures no analysis of dynamic excitations, except torsional vibrations, is taken into consideration. In certain circumstances the adoption of static load criterion may be disastrous especially in the case of resonance between natural vibration frequencies and those of external forces due to dynamic impacts.

To analyze the dynamic interaction a simplified model of shaft line is presented below, Fig. 1.

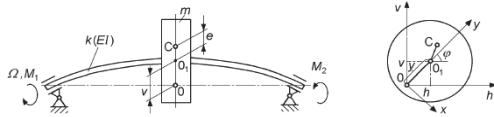

Fig. 1. A simplified shaft-line model for critical speed calculation [4]

Let us note: M_1 - torque, M_2 - anti-torque. The system can be represented by the following set of equations:

$$\begin{aligned} m\ddot{h} + kh &= me(\ddot{\varphi} \sin \varphi + \dot{\varphi}^2 \cos \varphi), \\ m\ddot{v} + kv &= me(-\ddot{\varphi} \cos \varphi + \dot{\varphi}^2 \sin \varphi), \\ (J + me^2)\ddot{\varphi} &= me(h \sin \varphi - v \cos \varphi) + M_1 - M_2 \end{aligned} \quad (1)$$

The presented form of the equations is non-linear. Considering the third of the equations (1) one can observe that the variables h , v and φ are mutually coupled. It means that any bending vibration would disturb rotational motion of the shaft. The third of the equations (1) can be written also in the equivalent form as follows:

$$J\ddot{\varphi} = ke(v \cos \varphi - h \sin \varphi) + M_1 - M_2 \quad (2)$$

To obtain the shaft angular speed Ω_w constant to use time-variable torque is necessary:

$$M = M_1 - M_2 = ke(h \sin \varphi - v \cos \varphi) \quad (3)$$

Theoretical analysis indicates that shaft bending deformation continuously accumulates a part of shaft torque. However the quantity of torque non-uniformity is rather low since shaft-line eccentricity is low; it results from manufacturing tolerance, non-homogeneity of material, propeller weight and permissible assembling clearances of bearing foundations. For minehunters propulsion system the torque pulsation expressed by means of Fourier series is much more complex. It additionally contains components resulting from number of propeller blades, kinematical features of reduction gear as well as disturbances from main engine and neighbouring devices. In general case occurrence of only one harmonic does not change reasoning logic. For long shaft lines of ships the influence of gravity forces on critical speeds should be taken into consideration [7]. According to Eq. (4) the generated vibrations will be then performed respective to static deflection axis of the shaft.

$$\begin{aligned} m\ddot{h} + kh &= me\Omega^2 \cos \varphi \\ m\ddot{v} + kv &= me\Omega^2 \sin \varphi \\ \ddot{\varphi} &= 0 \end{aligned} \quad (4)$$

Hence the equations obtain the following form:

$$\begin{aligned} \ddot{h} + \omega_0^2 h &= e \cdot \Omega^2 \cos \varphi \\ \ddot{v} + \omega_0^2 v &= e \cdot \Omega^2 \sin \varphi - mg, \\ J\ddot{\varphi} &= -mge \cos \varphi. \end{aligned} \quad (5)$$

Since in the third equation of the set (1), i.e. that for Ω_{3KR} , appears the exciting torque of the frequency/angular speed ratio $\beta=1$ it means that one has to do with the critical state of 2nd kind for $\beta=1$, namely:

$$\Omega_{KR(2)} = \frac{1}{2} \omega_0 \quad (6)$$

Occurrence of such kind vibrations is conditioned by non-zero value of e , which – in the case of ship shaft line – appear just after dislocation of a weight along ship, a change of ship displacement or even due to sunshine operation on one of ship sides. A similar situation will happen when e varies due to dynamic excitations resulting from e.g. sea waving or explosion. In this case the critical speed will vary depending on instantaneous value of e and damping.

Theoretical analysis of operational conditions of intermediate and propeller shafts indicates that static and dynamic loads appear. In a more detailed analysis of dynamic excitations of all kinds the following factors should be additionally taken into consideration:

- disturbances coming from ship propeller (torsional, bending and compressive stresses);
- disturbances from propulsion engine (torsional and compressive stresses);
- disturbances from reduction gear (torsional stresses);
- disturbances from other sources characteristic for a given propulsion system or ship mission.

3. UNDERWATER EXPLOSION

Knowledge of loads determined during simulative explosions is helpful in dimensioning ship's hull scantlings [3]. Another issue is possible quantification of explosion energy as well as current potential hazard to whole ship and its moving system. From the point of view of shock wave impact on shaft line, underwater and over-water explosions should be considered in two situations:

- when shock wave (or its component) impacts screw propeller axially,
- when shock wave (or its component) impacts screw propeller perpendicularly to its rotation axis.

The axial shock-wave component affects thrust bearing and due to its stepwise character it may completely damage sliding thrust bearing. Rolling thrust bearings are more resistant to stepwise loading hence they are commonly used on naval ships [3]. The shock wave component perpendicular to shaft

rotation axis is much more endangering. Shock wave can cause: damage of stern tube, brittle cracks in bearing covers and tracks, plastic displacement of shaft supporting elements including transmission gear and main engine, and even permanent deformation of propeller shaft. The problem of influence of sea mine explosion on hull structure is complex and belongs to more difficult issues of ship dynamics. Underwater explosion is meant as a violent upset of balance of a given system due to detonation of explosives in water environment. The process is accompanied with emission of large quantity of energy within a short time, fast running chemical and physical reactions, emission of heat and gas products. The influence of underwater explosion does not constitute a single impulse but a few (2 to 4) large energy pulsations of gas bubbles [2, 8, 9].

The pulsation process is repeated several times till the instant when the gas bubble surfaces. Hence the number of pulsations depends a.o. on immersion depth of the explosive charge. The character of changes of pressure values in a motionless point of the considered area is shown in Fig. 2.

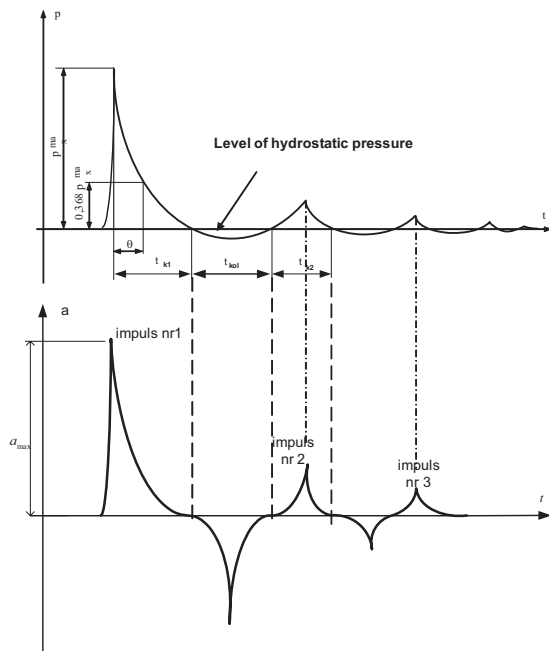

Fig. 2. Run of changes of shock wave pressure and ship hull acceleration measured on hull surface during underwater explosion

In the subject-matter literature can be found many formulae for determining maximum pressure value, based on results of experiments, however data on a character of pulsation and its impact on ship structures are lacking. To identify underwater explosion parameters a pilotage test was performed with the use of the explosive charge having the mass $m = 37,5$ kg. The schematic diagram of the experiment is shown in Fig. 3.

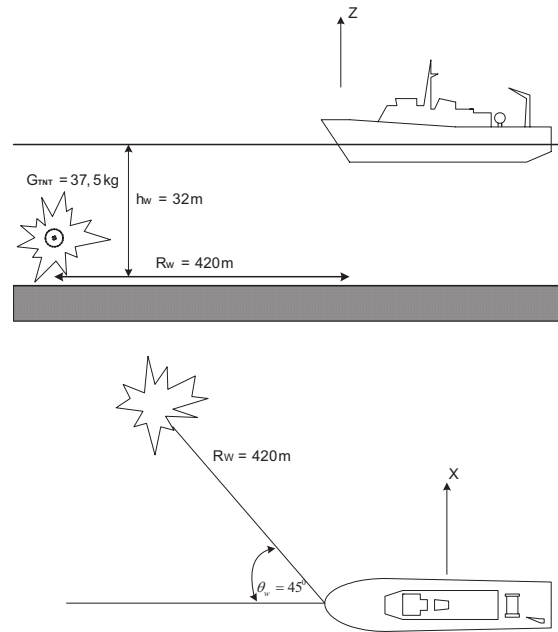

Fig. 3. Schematic diagram of the performed experimental test

During the test were measured vibration accelerations of casings of intermediate and thrust bearings in the thrust direction and that perpendicular to shaft rotation axis. The ship course relative to shaft rotation axis was 45^0 and the shaft line rotated with the speed $n_{LW} = 500$ rpm. Ship's distance from the mine and its immersion depth was determined by using a hydro-location station and ROV underwater vehicle – figure 4. The vibration gauges were fixed over the reduction gear bearing as well as on the intermediate shaft bearing.



Fig. 4. ROV vehicle with TNT charge

The measurement directions (X and Z axes) are presented in Fig. 5 as well. The time lag of the recorded signals was the same in all measurement points, as shown in Fig. 5 and 6.

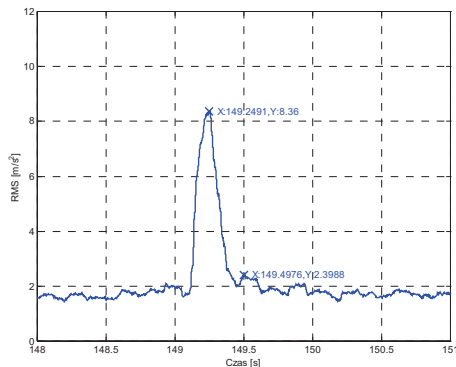

Fig. 5. Explosion, Port side (LB), Thrust bearing, X axis

The performed test was aimed at achieving information dealing with :

- character of shock wave impact on shaft-line bearings, in the form of recorded vibration parameters;
- assessment of time-run of vibration accelerations with taking into account dynamic features of the signals in set measurement points;
- assessment of possible identification of influence of pulsation of successive gas bubbles during the time-run of vibration accelerations;
- identification of features of the signals by means of spectral analysis.

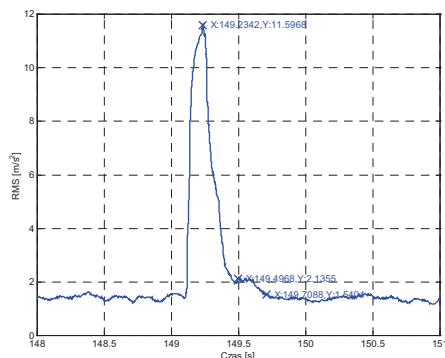

Fig. 6. Explosion, Starboard (PB), Intermediate bearing, Z axis

Since the mass of the explosive charge was small, to reliably identify the effect of only first and second pulsation was possible during the test.

4. MODELS OF EXCITATION DUE TO UNDERWATER EXPLOSION

Analysis of dynamic impacts including impulse ones should take into account basic parameters which influence character of time-run of a given signal as well as its spectrum. The basic parameters which identify impulse impact resulting from explosion are the following:

- form of impulse which identifies kind of impulse;
- impulse duration time t_1 at the ratio A/t_1 maintained constant, which identifies explosive charge power (time of propagation of gas bubble);
- influence of damping on spectrum form, which identifies distance from explosion and - simultaneously - epicentre depth
- number of excitation impulses, which informs on distance from explosion, combined with explosive charge mass;
- time between successive impulses, which characterizes explosive charge mass;

The possible recording of measured shock wave pressure and accelerations on intermediate and propeller shaft bearings enables to identify some explosion parameters hence also hazards to power transmission system. Analysing the run of underwater shock wave pressure one is able to assume its time-dependent function (Fig. 8 and 8):

$$A = at^{kb} \cdot e^{kct} \quad (7)$$

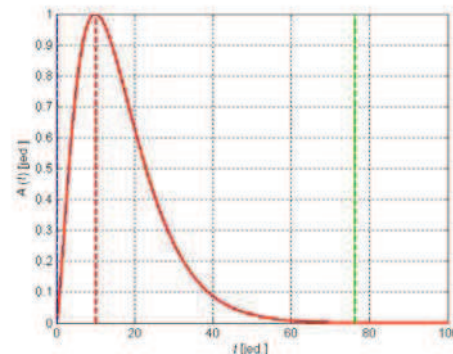

Fig. 8. Example of the function form for $b=1,5$, $c=-0,15$ and $k=1$

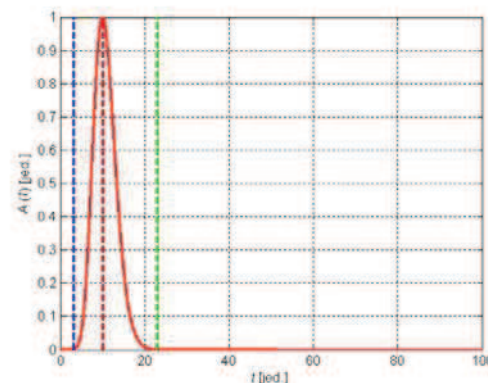

Fig. 9. Example of the function form for $b=1,5$, $c=-0,15$ and $k=10$

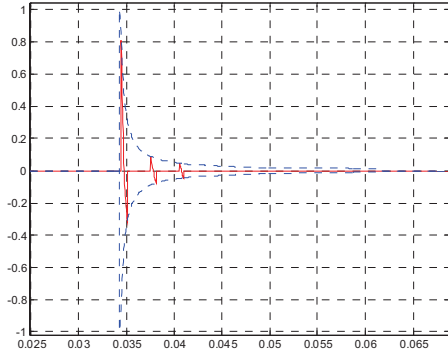

Fig. 10. Run of the assumed vibration acceleration model

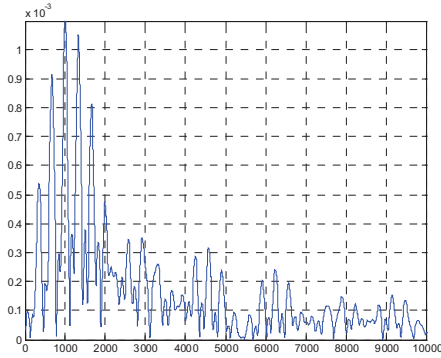

Fig. 11. Spectrum of the assumed vibration acceleration model

For the assumed mathematical model of the first shock wave impulse the run of vibration accelerations recorded on ship hull - for the example function given in Fig. 8 - can be presented as shown in Fig. 10 and 11.

5. MODEL OF SHAFTLINE

The model of shaft line is nonlinear and it is presented in Fig. 12.

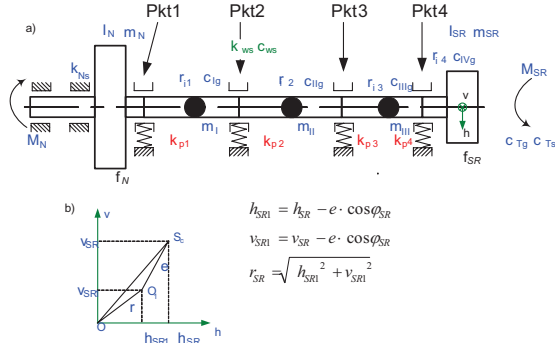

Fig. 12. Scheme of shaft line of minehunter where:

I_N ; m_N - reduced moment of inertia of the propulsion part,
 I_{SR} ; m_{SR} - reduced moment of inertia of the propeled part,
 M_N ; M_{SR} - torque and anti torque - propeller,
 m_I ; m_{II} ; m_{III} - reduced mass of shaft between bearings,

k_{Ns} - torsional stiffness of propulsion system,
 r_{I1} ; r_{I2} ; r_{I3} ; r_{I4} ; - coefficients of bending stiffness elements of shaft between bearings,
 c_{Ilg} ; c_{IIlg} ; c_{IIIlg} ; c_{IVg} - coefficients of bending damping elements of shaft between bearings,
 k_{ws} ; c_{ws} - coefficients of torsional stiffness and damping of the shaft,
 φ_N ; φ_{SR} - angles of rotation propulsion system and propeller,
 h_{SR} ; v_{SR} - horizontal and vertical coordinates of centre of gravity S_c (after the shaft deflection),
 h_{SR1} ; v_{SR1} - horizontal and vertical coordinates of centre of rotation O_1 ,
 h_N ; h_I ; h_{II} ; v_N ; v_I ; v_{II} - horizontal and vertical coordinates for masses m_N ; m_I ; m_{II} ,
 c_{Tg} ; c_{Ts} - resistance of water bending and torsional damping

The model fulfill following requirements:

- it allows to insert the environmental loads,
- it allows to insert to the model the impulse of underwater explosion,
- the model reacts to changes of rotational speed of shaft line,
- the model reacts for axes misalignment,
- it keeps concordance in spectral and time domains with real object.

The kinetic energy of the model of shaft line can be represented by the following equation:

$$E_k = \frac{1}{2} I_N \dot{\varphi}_N^2 + \frac{1}{2} I_{SR} \dot{\varphi}_{SR}^2 + \frac{1}{2} m_I (\dot{v}_I^2 + \dot{h}_I^2) + \frac{1}{2} m_{II} (\dot{v}_{II}^2 + \dot{h}_{II}^2) + \frac{1}{2} m_{SR} (\dot{v}_{SR}^2 + \dot{h}_{SR}^2) + \frac{1}{2} m_N (\dot{v}_N^2 + \dot{h}_N^2) \quad (7)$$

The potential energy is written as follows:

$$E_p = \frac{1}{2} k_{NS} \varphi_N^2 + \frac{1}{2} k_{ws} (\varphi_{SR} - \varphi_N)^2 + \frac{1}{2} k_{lg} (h_I^2 + v_I^2) + \frac{1}{2} k_{IIg} (h_{II}^2 + v_{II}^2) + \frac{1}{2} k_{IIIg} (h_{III}^2 + v_{III}^2) + \frac{1}{2} k_{IVg} (h_{SR1}^2 + v_{SR1}^2) \quad (8)$$

and the dissipated energy in form:

$$E_R = \frac{1}{2} c_{ws} (\dot{\varphi}_{SR} - \dot{\varphi}_N)^2 + \frac{1}{2} c_{Ts} \dot{\varphi}_{SR}^2 + \frac{1}{2} c_{lg} (\dot{h}_I^2 + \dot{v}_I^2) + \frac{1}{2} c_{IIg} (\dot{h}_{II}^2 + \dot{v}_{II}^2) + \frac{1}{2} c_{IIIg} (\dot{h}_{III}^2 + \dot{v}_{III}^2) + \frac{1}{2} c_{IVg} (\dot{h}_{SR1}^2 + \dot{v}_{SR1}^2) \quad (9)$$

It allows obtaining the second kind of Lagranges set of equations which can be represented as follow:

$$\begin{aligned} I_N \ddot{\varphi}_N + c_{ws} (\dot{\varphi}_N - \dot{\varphi}_{SR}) + k_{NS} \varphi_N + k_{ws} (\varphi_N - \varphi_{SR}) &= M_N \\ m_I \ddot{h}_I + c_{Ilg} \dot{h}_I + r_{11} h_I + r_{12} h_{II} + r_{13} h_{III} + r_{14} h_{SR} &= 0 \\ m_I \ddot{v}_I + c_{Ilg} \dot{v}_I + r_{11} v_I + r_{12} v_{II} + r_{13} v_{III} + r_{14} v_{SR} &= 0 \\ m_{II} \ddot{h}_{II} + c_{IIlg} \dot{h}_{II} + r_{21} h_I + r_{22} h_{II} + r_{23} h_{III} + r_{24} h_{SR} &= 0 \\ m_{II} \ddot{v}_{II} + c_{IIlg} \dot{v}_{II} + r_{21} v_I + r_{22} v_{II} + r_{23} v_{III} + r_{24} v_{SR} &= 0 \\ m_{III} \ddot{h}_{III} + c_{IIIg} \dot{h}_{III} + r_{31} h_I + r_{32} h_{II} + r_{33} h_{III} + r_{34} h_{SR} &= 0 \\ m_{III} \ddot{v}_{III} + c_{IIIg} \dot{v}_{III} + r_{31} v_I + r_{32} v_{II} + r_{33} v_{III} + r_{34} v_{SR} &= 0 \\ I_{SR} \ddot{\varphi}_{SR} + c_{ws} (\dot{\varphi}_{SR} - \dot{\varphi}_N) + c_{Ts} \dot{\varphi}_{SR} + c_{IIIg} (\dot{h}_{SR} \sin \varphi_{SR} - \dot{v}_{SR} \cos \varphi_{SR} + e^2 \dot{\varphi}_{SR}) + k_{ws} (\varphi_{SR} - \varphi_N) + r_{44} (h_{SR} \sin \varphi_{SR} - v_{SR} \cos \varphi_{SR}) &= M_{SR} \\ m_{SR} \ddot{h}_{SR} + c_{IVg} (\dot{h}_{SR} + \dot{\varphi}_{SR} \sin \varphi_{SR}) + r_{41} h_I + r_{42} h_{II} + r_{43} h_{III} + r_{44} (h_{SR} - e \cos \varphi_{SR}) &= 0 \\ m_{SR} \ddot{v}_{SR} + c_{IVg} (\dot{v}_{SR} - \dot{\varphi}_{SR} \cos \varphi_{SR}) + r_{41} v_I + r_{42} v_{II} + r_{43} v_{III} + r_{44} (v_{SR} - e \sin \varphi_{SR}) &= 0 \end{aligned} \quad (10)$$

The model of shaft line is implemented to the MATLAB SIMULINK software with accordance of mentioned requirements – Fig. 13.

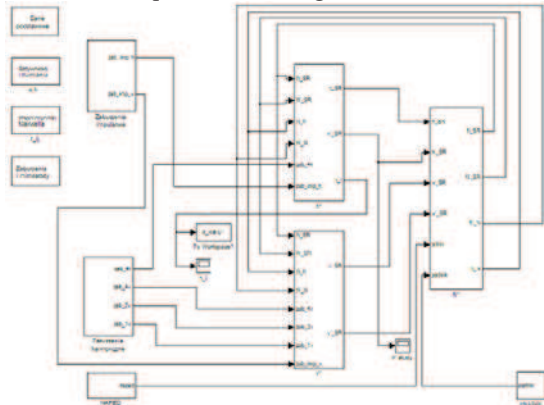

Fig. 13. Scheme of structure shaft line model in the MATLAB SIMULINK

Typical dangers for minhunter propulsion system are stresses coming from underwater explosion. Presented model allows calculating reactions in time and frequency domain. The example of spectrum of vibration acceleration in the point 3 of model (Fig. 12) during the simulated explosion is presented in the Fig. 14.

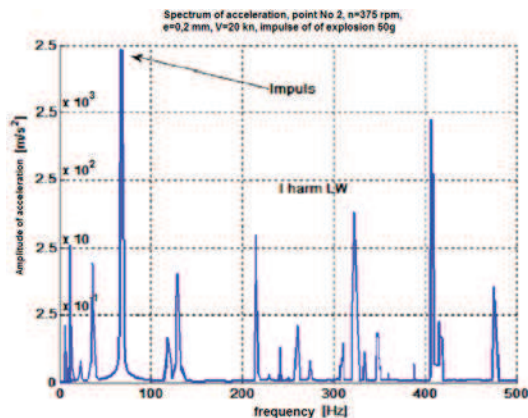

Fig. 14. The spectrum of acceleration with the inserted simulation of underwater explosion

6. FINAL CONCLUSIONS

It's common knowledge that failure frequency is the most hazardous factor in marine industry, just after aeronautics. Dynamic reactions which occur on ships in service at sea are rarely able to produce wear sufficient to cause a failure. The possible application of an on-line monitoring system of vibration parameters of the propulsion system of minehunter makes it possible to perform the typical technical diagnostic tests of torque transmission system and to identify possible plastic deformations of hull plating as a result of underwater explosion.

The modelling of impulse impact form and next its identification makes it possible additionally: to identify explosion power by using an analysis of the first vibration impulse amplitude and its duration time, to identify distance from explosion epicentre

(hence a degree of hazard) by analysing signal's damping, to identify a kind of explosion and even characteristic features of type of used mine, to select dynamic characteristics of a measuring system which has to comply with requirements for typical technical diagnostics and for a hazard identification system, to identify elastic or plastic deformation of shaft line by using spectral assessment of its characteristic features from before and after underwater explosion.

The presented results of modelling related to the performed experimental test do not make it possible - due to strongly non-linear character of interactions occurring in sea environment - to assign unambiguously the modelled signal features to those of the recorded ones during the real test.

Successive experimental tests will make it possible to verify features of the signals assumed for the analysis, to be able to build reliable models.

The wide range of stochastic dynamic loads acting on ships during its life-time makes that in the nearest future the application of on-line diagnostic techniques to ship propulsion systems, based on analysing vibration signals, will constitute an obvious tactical and technical necessity.

BIBLIOGRAPHY

- [1] Cempel Cz., Tomaszewski F. (Ed.): *Diagnostics of machines. General principles. Examples of applications* (in Polish), Publ. MCNEM, Radom 1992.
- [2] Cole R. H.: *Underwater Explosions*. Princeton University Press, Princeton 1948.
- [3] Cudny K., Powierża Z.: *Selected problems of shock resistance of ships* (in Polish) Publ. Polish Naval University, Gdynia 1987.
- [4] Dąbrowski Z.: *Machine shafts* (in Polish), State Scientific Publishing House (PWN), Warszawa 1999
- [5] Dietrych I., Kocańda S., Korewa W.: *Essentials of machine building* (in Polish). Scientific Technical Publishing House (WNT), Warszawa 1974.



Dr inż. **Andrzej GRZĄDZIELA** jest Kierownikiem Zakładu Napędów Okrętowych w Instytucie Konstrukcji i Eksploatacji Okrętów Wydziału Mechaniczno – Elektrycznego Akademii

Marynarki Wojennej w Gdyni. W swojej działalności zawodowej zajmuje się problemami oceny niewyrównowazenia i oceny współosiowości w okrętowych układach napędowych a także projektowaniem okrętów i doborem układów napędowych. Członek PTDT i PTNSS.