

*Jun Xie**, *Sheng Xue**, *Weiming Chen***, *Gang Zhou***

AN ENCLOSED DUST REMOVAL SYSTEM WITH DUCTING

1. Introduction

Roadway development with fully-mechanized technologies in underground coal mines greatly improves drivage rate, drive distance and productivity. However, dust produced with the technologies is quite high. At present, dust control in roadway development is mainly through water or mist spray and dust scrubber, however their effectiveness is not satisfactory [1]. For example, when mist spray is used the dust at the face of a developing roadway is measured between 1200 and 1500 mg/m³ and the dust exposed by a roadheader operator can reach as high as 500 mg/m³ [2], these dust levels are far too high above the allowable dust level of 10 mg/m³ set out in the Coal Mine Safety Regulation in China. One of main reasons resulted to these high dust levels is lack of To develop such technologies detailed understanding of on dust sources and its distribution at the face of a fully-mechanized roadway, and development of effective dust control technologies based on the understanding.

This paper describes the studies on the relationship between air flow and dust distribution at the face of a fully-mechanized roadway, establishment of an integrated gas-dust particle turbulent flow model, and numerical simulations of dust at the face with the model. Based on the results of these studies, an enclosed dust removal system with ducting was developed. The system was trialed in an underground coal mine. The system and the results of the trial are also presented in this paper.

2. Numerical modeling

A force-exhaust ventilation system is widely used in roadway development in underground coal mines. With this type of ventilation system, two electric fans (a forcing fan and an

* CSIRO, PO Box 883, Kenmore, QLD, Australia

** Shandong University of Science and Technology, Qingdao, China

exhausting fan) are installed. The forcing fan is located in intake air, forcing fresh air into the face. The exhausting fan is located close to the face, exhausting dust-laden air at the face via ducting. Not all of the dust-laden air at the face can be exhausted via ducting, and some of the dust-laden air is ventilated out along the roadway.

2.1. Mathematical model

With the force-exhaust ventilation system, the flow at the face is turbulent gas-solid (air and dust particle) flow. The gas flow can be modeled with a two-equation $k - \varepsilon$ model of high Reynolds number [3]. The solid particle flow can be described with the Eulerian-Lagrangian model [4]. Modeling of the two-phase gas-solid turbulence flow is complex. In this study, the gas-solid turbulent flow at the roadway development face is modeled with the $k - \varepsilon - \Theta - k_p$ model [5] which is the integration of the $k - \varepsilon$ model (gas-phase flow model) with the Eulerian-Lagrangian model (solid particle flow model). The model is suitable for simulation of gas-solid (dust) flow at the face [6].

The general expression of gas phase control equation flow in polar coordinates can be described as:

$$\begin{aligned} & \frac{\partial}{\partial x}(\alpha_g \rho_g u \varphi) + \frac{\partial}{r \partial x}(r \alpha_g \rho_g v \varphi) + \frac{\partial}{r \partial \theta}(\alpha_g \rho_g w \varphi) = \\ & = \frac{\partial}{\partial x} \left(\Gamma_\varphi \frac{\partial \varphi}{\partial x} \right) + \frac{\partial}{r \partial r} \left(r \Gamma_\varphi \frac{\partial \varphi}{\partial r} \right) + \frac{\partial}{r^2 \partial \theta} \left(\Gamma_\varphi \frac{\partial \varphi}{\partial \theta} \right) + S_\varphi + S_{\varphi g} \end{aligned} \quad (1)$$

The general formulation of solid phase control equation is:

$$\begin{aligned} & \frac{\partial}{\partial x}(a u_p \varphi_p) + \frac{\partial}{r \partial x}(r a v_p \varphi_p) + \frac{\partial}{r \partial \theta}(a w_p \varphi_p) = \\ & = \frac{\partial}{\partial x} \left(\Gamma_{\varphi p} \frac{\partial \varphi_p}{\partial x} \right) + \frac{\partial}{r \partial r} \left(r \Gamma_{\varphi p} \frac{\partial \varphi_p}{\partial r} \right) + \frac{\partial}{r^2 \partial \theta} \left(\Gamma_{\varphi p} \frac{\partial \varphi_p}{\partial \theta} \right) + S_{\varphi p} + S_{\varphi p g} \end{aligned} \quad (2)$$

2.2. Physical model

The roadway development model is set as 25 m in length (direction X), 3.5 m in width (direction Y), and 4 m in height (direction Z). A duct of 0.8 m in diameter installed near the rib of the roadway (force duct) is for forcing fresh air into the development face. Another duct of 0.8 m in diameter placed in the middle of the roadway is for exhausting contaminated air away from the face (exhaust duct). One end of the exhaust duct is 2.5 m away from the face. The physical model of the roadway is shown in Figure 1. Main boundary conditions and input parameters of the model are listed in Table 1. FLUENT (CFD software) is used in the simulation.

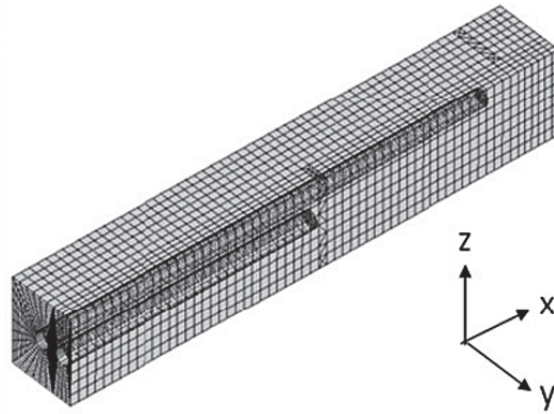

Fig.1. The physical model of roadway

TABLE 1

Main boundary conditions and input parameters

Entry type	VELOCITY_INLET
Outlet type	OUTFLOW
Inflow flow velocity, m/s	0.3
turbulent dynamic energy, m^2/s^2	0.8
Turbulent diffusion ratio, m^2/s^3	0.8
Dust size distribution	Rosin-Rammler
Median diameter of dust, m	4.57×10^{-6}
Maximum size of dust, m	2.185×10^{-5}
Minimum size of dust, m	0.85×10^{-6}
Initial velocity of dust, m/s	0
Mass flow rate of dust, kg/s	0.021

2.3. Modeled results

Simulated dust concentrations at cross sections in X , Y and Z directions, are discussed in this section.

Figure 2 shows the simulated results of dust concentration at several cross sections in X direction at 0 m, 15 m, and 25 m from the exit end of the exhaust duct.

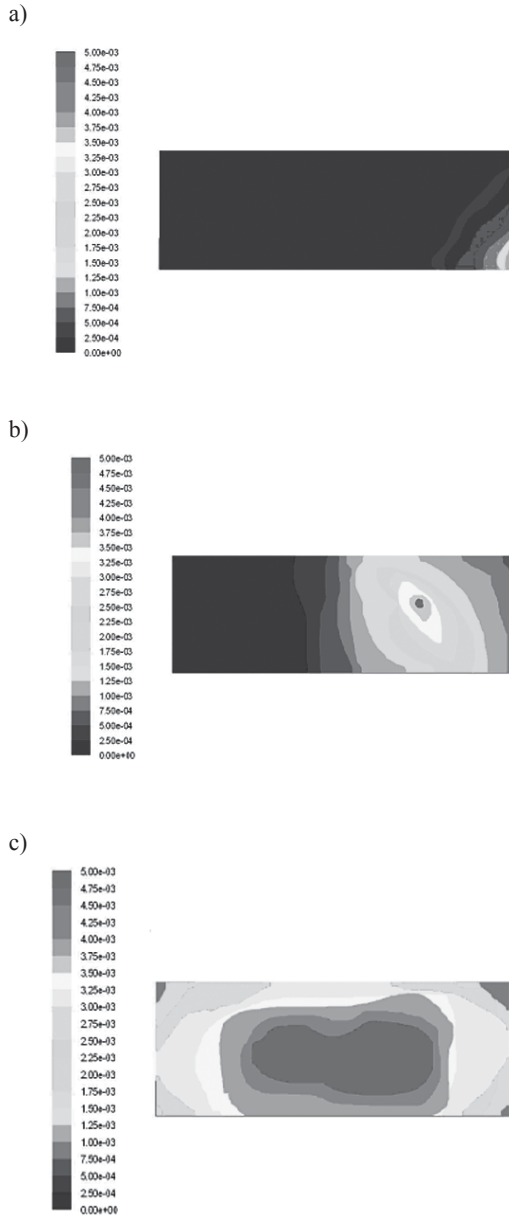

Fig.2. Dust concentrations at several cross sections along X direktion:
a) $x = 0$; b) $x = 15$ m; c) $x = 25$ m

Results in figure 2 show that:

- The maximum dust concentration reaches 4800 mg/m^3 during coal cutting operation of the face;
- At the 25 m cross section, dust concentration reaches 3700 mg/m^3 , this high concentration is resulted from the operation of coal cutting machine at the face and a short distance (2.5 m) between the exhaust duct and the face;
- Some large particles (dust) undergoing irregular diffusion movement are gradually settled on ground, this is effected by air flow and exhaust ventilation;
- At the 0 m or the exit end of exhaust duct the dust generated in previous locations is gradually mixed and diffused in the entire roadway, and the dust concentration at this location is reduced to 240 mg/m^3 .

Figure 3 shows the simulated results of dust concentration at several cross sections in Y direction at 0 m, 1.8 m, and 3.5 m from the air-intake rib of the roadway.

Results in Figure 3 show that:

- At the 0 m cross section, dust concentration is reduced to 1600 mg/m^3 because it is on the air-intake side and dust generated during coal cutting operation undergoes turbulent flow under the influence of air flow;
- The dust concentration along the middle of the roadway or the middle line of the exhaust fan is relatively high, exceeds 3800 mg/m^3 , because of the influence of negative pressure generated by the exhaust fan;
- The dust concentration in the return rib side increases as the distance to the air intake rib side decreases, reaching between 1640 and 2400 mg/m^3 .

Figure 4 shows the simulated results of dust concentration at several cross sections in Z direction at 0 m, 2 m, and 4 m from the floor of the roadway.

Results in Figure 4 show that:

- As the distance from the floor of the roadway increase, dust concentration increases, reaching a maximum at the location of exhaust duct, and then gradually reducing until the roof of the roadway is reached;
- dust concentration at the face is the largest, reaching 4300 mg/m^3 , and it dust gradually decrease as the distance from the face increases;
- At the height of 1.6 m where miner breathes air, the dust concentration is between 1500 and 2000 mg/m^3 .

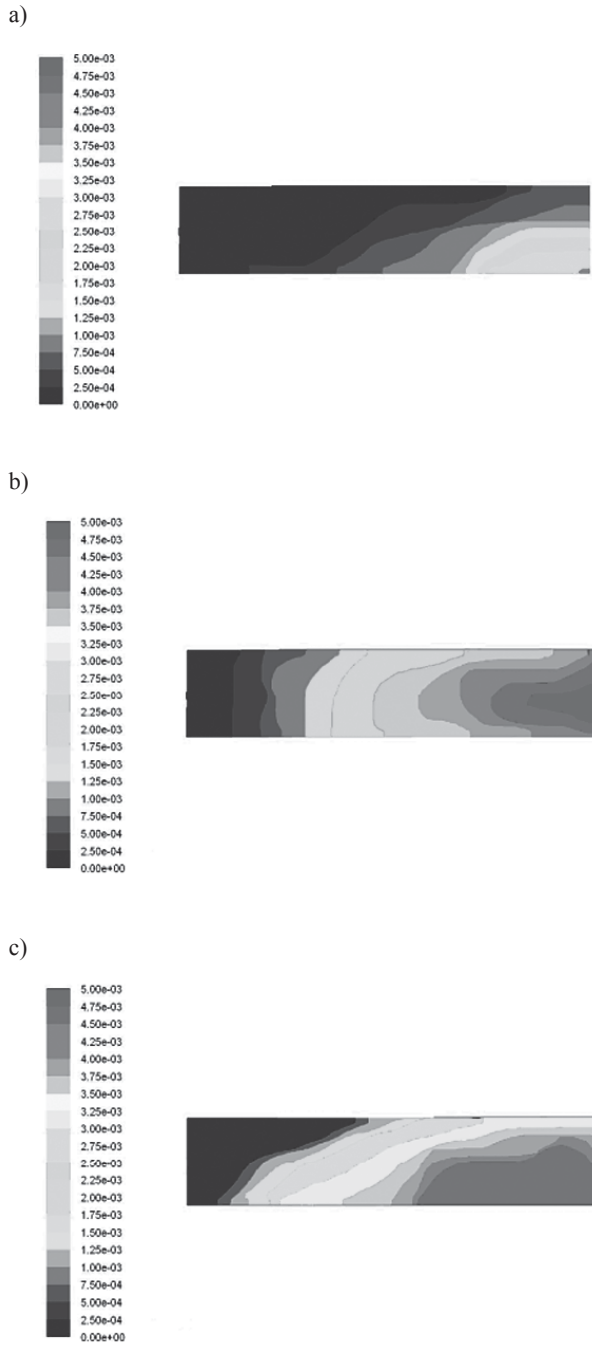

Fig. 3. Dust concentrations at several cross sections along Y direction:
 a) $y = 0$; b) $y = 1.8$ m; c) $y = 3.5$ m

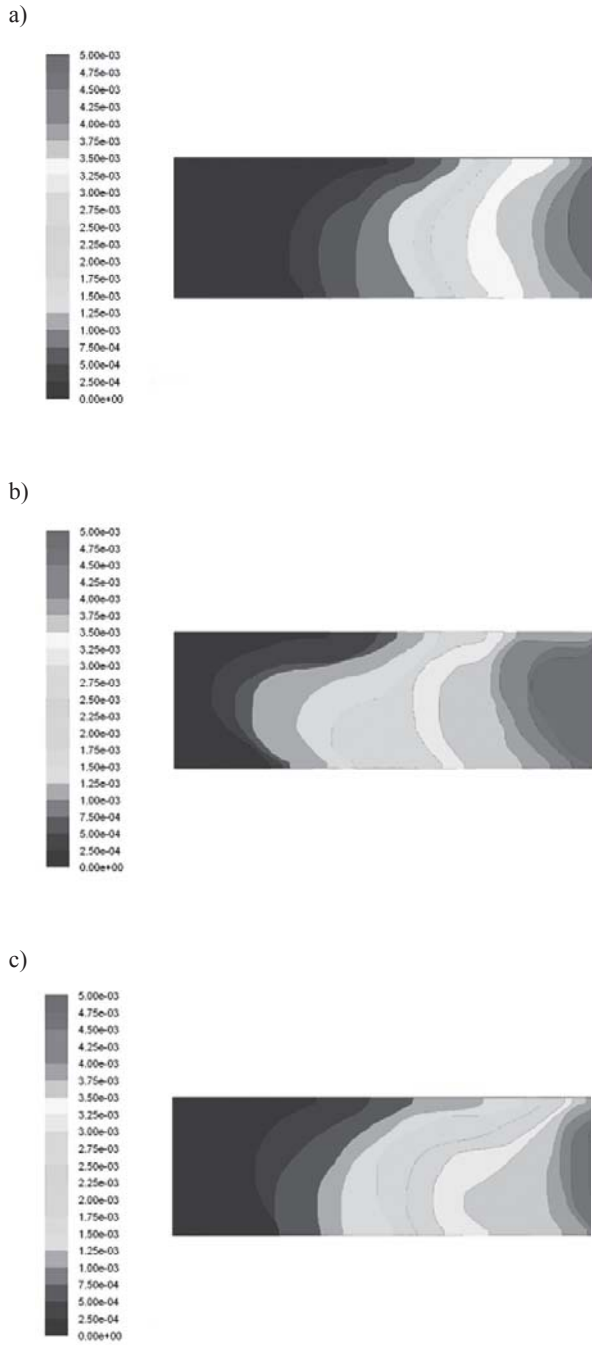

Fig. 4. Dust concentrations at several cross sections along Z direction:
 a) $z = 0$; b) $z = 2$ m; c) $z = 4$ m

3. Design of an enclosed dust control system

The results from the numerical modeling show that dust concentration in the middle of the roadway or the breathing zone of miners or 1 to 2 m above the floor of the roadway is the highest, and it should be the focus of dust control, i.e. should be the focus of dust control, i.e. the inlet of an exhaust fan should be positioned about 1 to 2 m above the floor. For the convenience of face operation, the exhaust duct should be fitted in coal cutting machine. In consideration of practical circumstances, the upper end of the inlet of the exhaust duct is set at 1.7 m above the floor and the inlet end is 2.5 m away from the face.

3.1. Principle of the system

An enclosed dust control system (EDCS) consists mainly of wet vibration dust removal fan, wire muffler, high-strength vacuum duct, rotating suction device, rib attaching duct. The schematics of the system are shown in Figure 5.

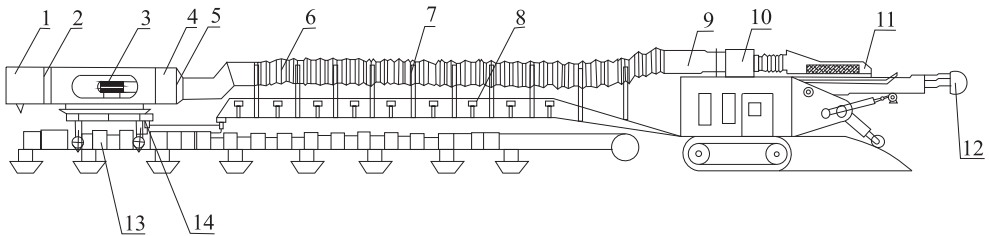

Fig. 5. Schematics of the enclosed dust control system:

- 1 — outlet of dust scrubber, 2 — filtering plate, 3 — electric motor, 4 — wire muffler,
- 5 — duct connector, 6 — vacuum duct, 7 — support frame, 8 — coal conveyor,
- 9 — coal cutting machine, 10 — rib attaching duct, 11 — suction device,
- 12 — cutting head, 13 — track, 14 — movable base

The main principle of the system includes three aspects:

- As dust-laden air flows through vibration filtering plate, water sprayers mounted in the inlet air flow direction spray mist to the plate. The mist-containing fiber produces vibration under the impact of the air flow, strengthening conflict between mist particle and dust in the air and increasing capture of tiny dust. The vibration also increases self-cleaning capability of the filtering plate.
- As water from the sprayers continuously mists the filtering plate, the dust-laden air passed through the plate becomes a mixture of mist and clouds of wet dust particles. Some of the dust particles are captured as mist curtain thickens, and flow with water under their own gravity. The clouds of dust particles are separated from water in a dust-water separator, water from separator is discharge or enters into a circulation tank for reuse, and air is cleaned and discharged.

- The rotating suction device takes advantage of rib-attaching effect of the rib-attaching duct to change the flow rotation of air along the rib of the roadway, enabling the dust-laden air to be sucked into the dust scrubber and cleaned and this increases dust capture efficiency at the face of a developing roadway.

3.2. Design of some components of the system

Under dual action of the rib-attaching effect of air flow and axial velocity generated by sucking dust-laden air into the dust scrubber, a spiral air flow from rib-attaching duct can be formed and an air curtain in front of the operator of a coal cutting machine at the face can be produced to block dust generated during coal cutting at the face from diffusing outward [7]. The rib-attaching duct is designed to be mounted on a movable base to enable it moving with development face. The duct has a controllable vent door. During coal cutting operation the door is closed to force fresh air to flow out along the sidewall of the duct into the face in a spiral form. When there is no coal cutting operation, the door is open to allow fresh air to flow out from the duct to the face. In designing the rib-attaching duct, considerations have also been given to avoid the occurrence of air recirculation by keeping a certain distance between the exit of the dust scrubber and the rib-attaching duct.

The dust scrubber is mounted on the movable device at the rear of coal conveyor, enabling the scrubber moves simultaneously with the conveyor and coal cutting machine. The scrubber uses highly efficient wet-based vibration dust removal device. A small and high efficient centrifugal fan is selected. The device uses interactive contact between water and dust-laden air, to separate dust from air. Meanwhile an umbrella-shaped stainless steel spray nozzle of 1.5 mm is installed to create water mist. Water pressure used for mist spray is 3 MPa.

The dust cover is mounted at the top of a coal cutting machine and between the drum of the machine and the protection plate of air curtain. The cover is connected with a rotating air inlet device through a flexible duct to form a rotating suction device. The cover can rotate or move forward with the cutting arm of the coal cutting machine to ensure that the suction device is a certain distance from the source of dust to enable effective suction of dust.

4. Field trial of the system

The system was trialed during a roadway development in 1101 panel at Gaozhuang coal mine in China. Dust concentrations at three locations of the roadway (working face, operator's position, and the end of conveyor) were measured with and without the enclosed dust control system. The measurement locations are shown in Figure 6 and the measured results are shown in Table 2.

It can be seen from the measured dust concentrations that dust concentration in working area was dramatically reduced with the use of the enclosed dust control system. At the cutting face, the dust concentration was reduced from 1184.3 mg/m³ to 142.1 mg/m³, a drop of more than eight times or dust capture ratio of 88%; at the operator's position, the reduction was

nearly 20 times or dust capture ratio of 95%; and at the end of coal conveyor, dust concentration was suppressed by 16 times or dust capture ratio of 94%.

TABLE 2
Measured dust concentrations

Location	Without EDCS, mg/m ³	With EDCS, mg/m ³
1	1184.3	142.1
2	303.9	15.8
3	199.6	12.6

5. Conclusions

The main conclusions from the study can be drawn as follows:

- In roadway development, dust control should focus in the area where the operator of coal cutting machine works;
- The enclosed dust control system is effective in dust removal in the working area of roadway development, a field trial of the system indicates that with the use of the system dust concentration in the working area can be reduced by 8 to 20 times or dust capture ratio of between 88 to 95%;
- The enclosed dust control system can be easily integrated into coal cutting machine and coal conveyor, making the system easy to be applied in roadway development.

Nomenclature:

- k — Turbulence kinetic energy,
- k_p — Stokes number,
- S_ϕ — source term,
- u — component of velocity in direction x ,
- v — component of velocity in direction y ,
- w — component of velocity in direction z ,
- α — fraction of gas volume,
- ϕ — a generalized dependent variable,
- ρ — den sity,
- ε — rate of dissipation of turbulence energy,
- Θ — temperature,

Γ_ϕ — coefficient of diffusion,
 g — gas phase subscript,
 p — solid phase subscript.

REFERENCES

- [1] *Liu Y.*: A study on dust flow and dust removal with high-pressure mist spray at a fully-mechanised coal mining face. Beijing University of Science and Technology, 2006.
- [2] *Nie W., Cheng W.M., Guo Y.*: Safety in Coal Mines 2009 (3), p. 19–21.
- [3] *Launder B.E., Spalding D.B.*: Computer Methods in Applied Mechanics and Engineering, Vol. 3 (1974), p. 269–289.
- [5] *Berlemont A., Desjonqeres P., Gouesbet G.*: International Journal of Multiphase Flow, Vol. 16(2) (1990), p. 16–34.
- [6] *Wang X.Z., Jiang Z.A., Wang S., Liu Y.*: Journal of China Coal Society, Vol. 32 (2007), p. 386–390, 2007.
- [7] *Yang S.L.*: Dust Distribution at a Fully Mechanized Working Face and Computer Simulation. China University of Mining and Technology, Beijing, 1995.