

*Jacek Jarosz\**

## ESTIMATION OF THE RANGE OF FRACTURED ZONE IN THE ROOF OF UNDERGROUND ROADWAYS USING THE SEISMIC METHOD

---

### 1. Introduction

The disadvantageous conditions (mining and geological) prevailing in Polish underground mines are responsible for a number of natural hazards (rock bursts, rock slides, rock and gas outbursts, water seepage, methane accumulations etc.). Despite the advances in exploitation technology, these hazards continue to be a significant hindrance to safe and efficient underground work. In the most cases, the danger is associated with rock mass fractures surrounding the mine workings, where the natural fractures and cracks are overlaid with a system of fractures caused by mining. These fractures are in the consequence of the disturbance of the existing equilibrium in the rock mass and the primary stress field changes. By this reason the new stress field forms where the stresses (tensile or compression) exceed the strength of the rock, which leads to a spreading process of rock destruction.

One can find examples of theories attempting to describe the shape and dimensions of the fractured zone around mine excavations [1]. According to the most widely promulgated theory of “pressure arches”, the fractured zone in the rock medium surrounding the workings has an elliptical boundary [12]. The size of the ellipse can be determined analytically for a given depth and a given type of rock, based on the compression parameters [2, 3]. Such analytical solutions pertain to a homogenous rock medium and can be used to work out a preliminary estimate of the extent of a fractured zone. In order to explore this zone more precisely (for engineering purposes) measurement and observation methods are widely used in the mining practice [4, 11, 5]. These methods are based on an analysis of changes of the appropriate physical parameter of the rock medium. It should be obvious that as a result of structural transformation the physical properties of the fractured zone are differed from the unfractured rock mass. The essence of the changes taking place in the vicinity of a fractured zone provides a basis for using the seismic method to explore this zone. The fractured zone is differentiated from the unmined coal by the values of the com-

---

\* Polish Academy of Sciences, Mineral and Energy Economy Research Institute, Cracow, Poland

pression parameters (which in turn determine the propagating wave parameters). This makes it possible for the space in the vicinity of a mine excavation to be treated as a system of two media with different properties. In such a system, as in the case of surface waves, it is possible that Love and Rayleigh interference waves may arise and propagate [6]. These waves are dispersed along the length of the mine excavation at velocities that differ from the velocities of other waves observed in the medium. If a proper measurement methodology is used, it is possible to identify and analyse these waves. The parameters of the interference waves (velocity and frequency) depend on the parameters of the fractured zone where these waves propagate. The wave analysis gives a chance to identify the range of the fractured zone.

In point of view of the extensive discussion of the theoretical basis for the appearance and propagation of Love-type interference waves [7, 4], only the most important properties have been presented in the paper. These parameters are essential to their utilization in mining practice. Among the basic parameters that differentiate these waves from the others components of wave packet are dispersion of velocity and concentration of energy.

## 2. The use of Love-type wave in field measurements

Dispersion is a phenomenon that comes into play when the velocities of dispersion of monochromatic waves that makes up a wave group depends on the frequencies of these waves. The particular components of a wave packet that differ slightly in terms of wave length can interfere with and amplify each other. This phenomenon, depending on the geometry of the rock medium in which the waves are propagating, may lead to the formation of new types of waves. In the case of a planar parallel stratum (such as a coal bed), channel waves known as “seam waves” can be formed as a result of interference [9]. In the fractured zone around mine workings, however, Love-type interference waves may propagate as the result of a superposition of incident and SH reflected lateral horizontal polarized waves [6].

As a result of interference of components having similar frequencies one may observe in a record of a wave packet a marked amplification of the amplitude of vibrations, the maximum of which is called the “Airy phase”. The frequency at which the wave amplitude resulting from the interference reaches its maximum is known as the “Airy frequency”. The wave packet associated with the Airy phase can be observed at significant distances from the source. This results from the fact that the wave amplitude in the Airy phase goes down with the distance at the rate of  $x^{1/3}$ , whereas for other frequencies at the rate of  $x^{1/2}$  [10]. The basic parameters of the packet in the section containing the Airy phase are the velocity, which the packet moves with, and the suitable packet frequency. The wave packet in the Airy phase propagates with a velocity equal to the minimum group velocity, which value can be read from the dispersion curve. This velocity is smaller than the velocity of the SH-type transverse wave in a fractured medium.

Love-type interference waves can be described using the so-called “dispersion curve” [7]. Sample dispersion curves corresponding to the seismo-geological model of a roadway in a coal mine are presented in Figure 1.

The shape of dispersion curves, and thus also the position of the characteristic points, depends on the parameters of both the fractured and unfractured rock-mass. This dependence can be tracked by constructing velocity dispersion curves for successive models of the medium [4].

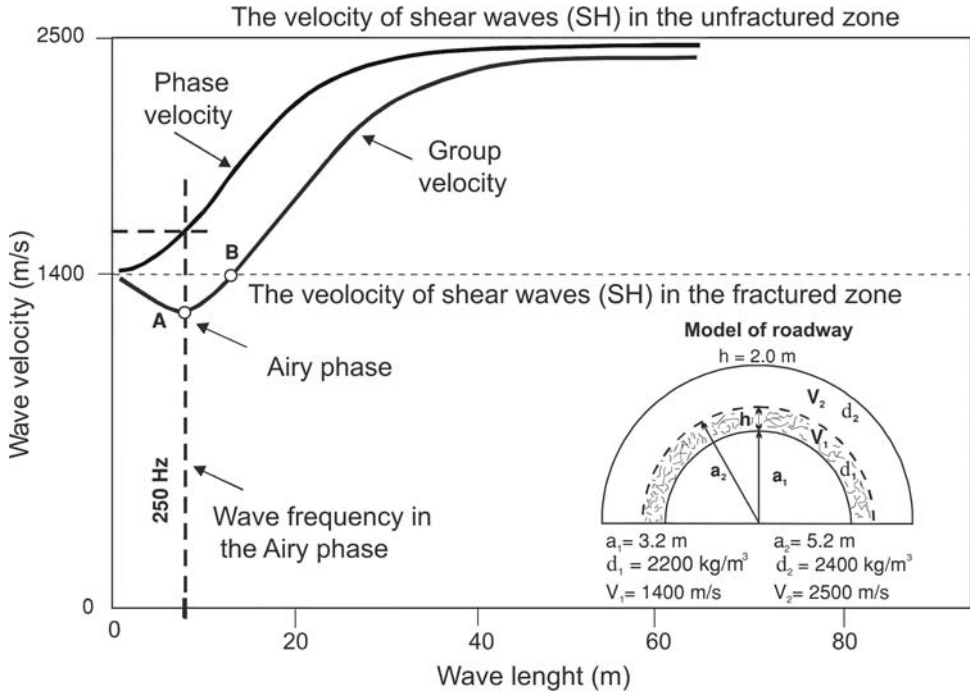
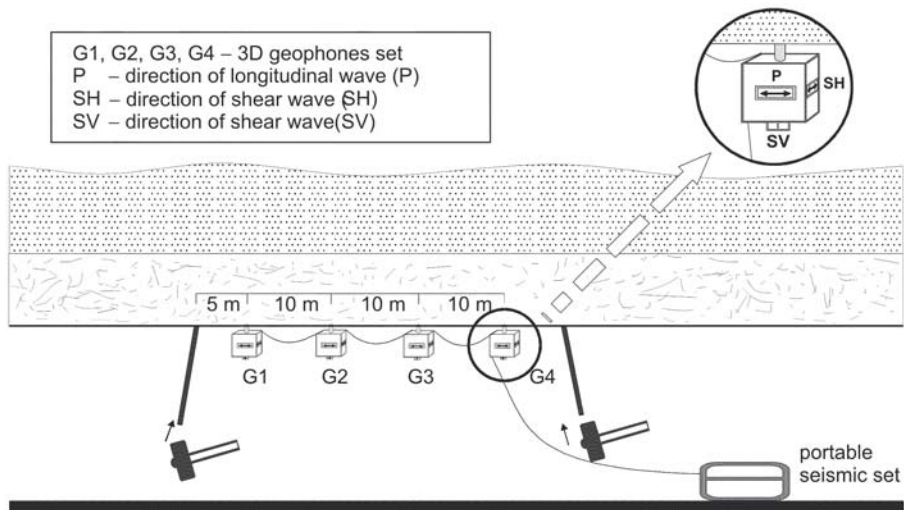

**Fig. 1.** Phase and group velocity waves calculated for a hypothetical model of roadway

An analysis of these curves makes it possible to define two basic rules:

- 1) For rising values of: the range of the fractured zone, the velocity of the transverse wave in the unfractured medium and the density of the unfractured rock-mass — the wave frequency in the Airy phase goes down.
- 2) For rising values of: the SH-type wave velocity in the fractured zone, the density of the fractured zone and the diameter of roadways — the wave frequency in the Airy phase goes up.

In terms of measurement, the method can be reduced to performing a seismic profile in the roof along the workings, using a 3-D geophones system (depending on the type of the apparatuses) to register the waves aroused by a mechanical stroke. The geometry of the seismic profile (the distance between the geophones and the value of source-receivers offset) is established in dependence on the parameters of the medium [4]. A sample diagram of a measuring system is presented in Figure 2.



**Fig. 2.** Scheme of a measurement layout used to register Love-type waves

The essence of the interpretive aspect of the method is to identify Love-type waves in the recorded signals. Their obvious peaks in the upper frequency bands mark out these waves. Figure 3a presents a signal along with the spectrum recorded in the roof of a roadway in a coal mine.

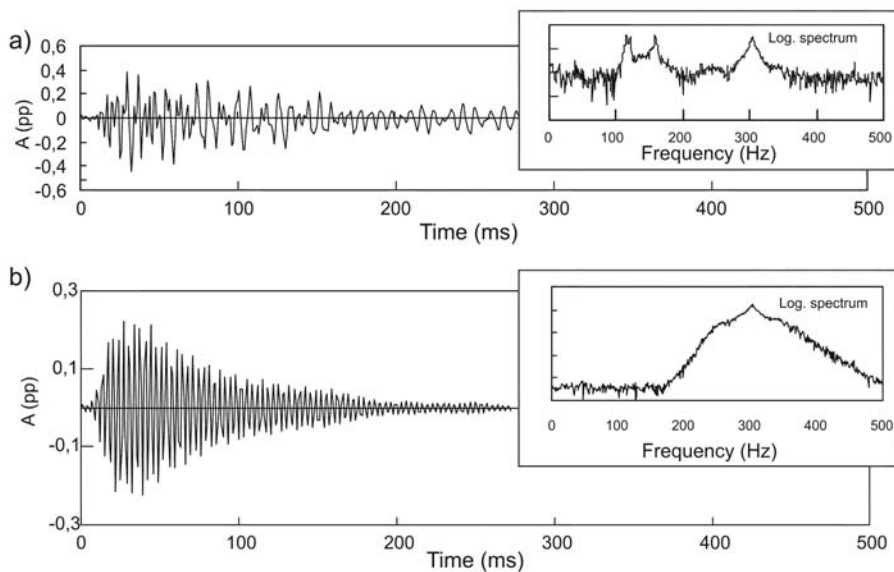

**Fig. 3.** A sample registration of Love-type interference wave:

- a) signal and spectrum before filtration;
- b) signal and spectrum after use of Butterworth band-pass filter (250–300 Hz)

In the upper frequency band (ca. 300 Hz), a high-energy component can be seen, which is presented in Figure 3b after signal filtration. This component, which is clearly of an interference nature, represents a Love-type interference wave. The dominant frequency of this element is associated with the Airy phase. After the interference elements in the recorded signals and their dominant frequencies have been identified on the basis of the dispersion curves, the extent of the fracture zone is calculated. The dispersion curves are constructed for a model of the medium, one of which parameters is the depth of the fracture layer (with reduced seismic wave propagation). The Airy frequency derived from a spectrum analysis is identified with the dispersion curve corresponding to the given model of the medium. A similar analysis performed at a number of measurement points makes it possible to estimate the extent of the fractured zone surrounding a particular profile. The greater the difference in acoustic hardness between the fracture zone and the undisturbed coal body, the better results produced by this method.

### 3. Field experiment in a coal mine

On the basis of the theoretical considerations and analytical models, the measurements in the coal mine were carried out. The purpose of those works was to estimate the range of the fractured zone in the roof of a roadway with view to design an optimum roof support system. Investigations were conducted in the roof of a roadway along the distance of 540 m. There were three geological exploration boreholes drilled in the area. Based on the information from these holes it was known that the roof of the roadways was composed of: mudstone (1.9 m), sandy shale (3.0 m), sandstone (0.6 m), mudstone (4.8 m) and sandy shale (4.7 m). There were sandy shale and mudstone in the floor of the roadway.

The portable 12-channel digital seismic recorder PASAT 12i with the transfer band of 10–1000 Hz, 72 dB dynamics and the frequency of signal sampling up to 10 000 Hz was used for the measurements. The signals were recorded using three-component geophone units having the linear range of vibration transfer in the band of 35–850 Hz. During the research 372 seismic signals in 44 measuring points were recorded.

To estimate the roof fractured zone range using the Love-type waves dispersion theory five parameters are required (see Fig. 1):

- 1) mass density of unfractured zone,  $d_2$ ;
- 2) mass density of fractured zone,  $d_1$ ;
- 3) velocity of SH wave in the unfractured zone,  $V_2$ ;
- 4) velocity of SH wave in the fractured zone,  $V_1$ ;
- 5) the dominant frequency at the Airy's phase.

In the case of the experiment in question, three values (1, 2 and 3) of these parameters were obtained from the geological boreholes and from laboratory measurements. These values were recognized as constant along the seismic profile.

The following values accepted:

- $d_2 = 2400 \text{ kg/m}^3$ ,
- $d_1 = 2200 \text{ kg/m}^3$ ,
- $V_2 = 2500 \text{ m/s}$ .

The dominant frequency at the Airy's phase was identified in the spectrum of the registered signals as specific vibrations in the higher band of frequency (Fig. 3). The velocity of SH-type wave in the fractured zone ( $V_1$ ) was calculated from the field measurements. Profiling of the SH velocity in the fractured zone along the measurement profile was done using a portable seismic set. The velocity of the transverse SH-type wave was determined for each measuring point. That velocity varies between 1320 and 1780 m/s and averages 1520 m/s. Using the values determined at the laboratory and the measured velocities of SH waves in the fractured zone along the seismic profile, four models of the medium were built. The models varied with value of velocity of SH-type waves in the fractured zone: 1400 m/s, 1500 m/s, 1600 m/s and 1700 m/s. For each of the models, by changing range of the fractured zone from 1.0 m to 5.0 (in 0.5 m steps), curves of dispersion (similar to the curve from Figure 1) were constructed and the values of wave frequency in the Airy phase were read from the curves. In effect, four parametric curves (range of fracture zone vs. frequency of Airy phase) were constructed (see Fig. 4).

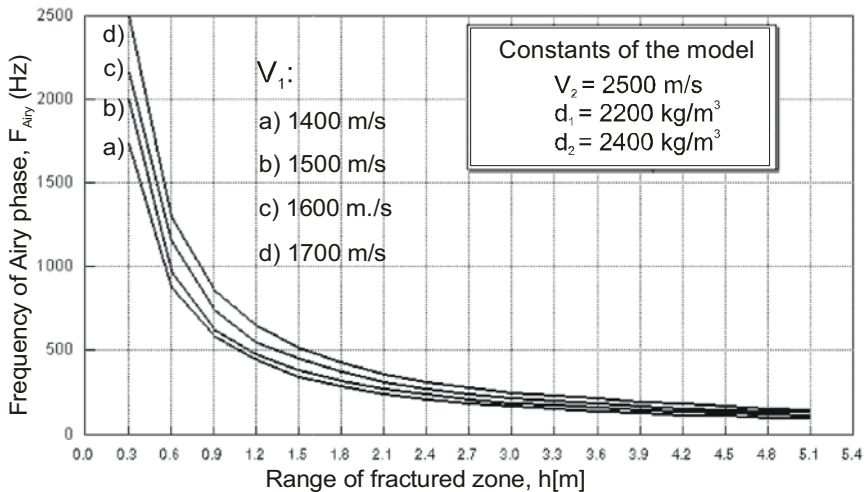

**Fig. 4.** Parametric curves for four models with different velocities of SH-type waves in the fractured zone

The method of establishing the radius of a fracture zone based on the analysis of interference transverse SH-type waves requires determination of dominant frequency value corresponding to the Airy phase. In order to estimate this value, each of the registered seismic signals was transposed to frequency domain and the frequency spectrum was analysed. After the analysis, it was considered that there were two main bands of dominant frequencies in the most of the signals. The lower one (0–200 Hz) — wasn't related to the Airy phase due to the lack of interference character of the registered signal in the band. The higher band (250–500 Hz) had a very clear dispersive and interference character e.g. non-attenuated oscillations and high amplitude. So it was necessary to look for the Airy's phase frequency in this range of frequencies. The next step of the signal analysis was establishing the dominant frequency in the higher band of the spectrum. The dominant frequency, des-

cribed in the 44 registered signals was changed from 220 Hz to 440 Hz. Using the table of dominant interference frequencies and curves shown on figure 4 the range of the fracture zone along the line of the profile was calculated. The value hesitates from 1.35 m up to 2.55 m with the average value ca. 1.9 m.

The results of the estimation of the fractured zone range using seismic method were compared with the results obtained by observation in borehole, which confirm the average thickness of that zone at the height of 2.0 m. To assure a suitable margin of safety, a support system comprising 2.5 m long bolts was designed for that roadway.

## 4. Conclusions

Numerous practical applications have confirmed the suitability for underground workings of the seismic method presented in the paper. It is particularly useful in cases of measurements over a huge area, e.g. for choosing the bolt length for cross roads.

The results of theoretical considerations and experimental works lead to the following conclusions:

1. The seismic method can be an economic way of constant estimation of the extents of fractured zones in roofs of roadways. The best results are achieved when the method is used together with bore-hole methods.
2. The interference waves method, by multiple measurements on a given rock profile, can be used to monitor the development of the process of deterioration of an area during a period of time.
3. With the use of this method not only the range of a fractured zone can be estimated. Seismic measurements give partial qualitative information about fracture density. That additional information is hidden in the measured values of SH waves velocities and the Airy's phase frequencies — a decrease of the velocity is related to a decrease of the dominant frequency of the Airy's phase in the registered signals. The signals weakening depend on deterioration of the geomechanical parameters of the roof rocks.
4. It is possible to accomplish many tasks ensuring continuous mining and stability of underground roadways, e.g. designing support systems and evaluation of rock mass condition by using the properties of the interference waves, which are generated in the rock medium.

## REFERENCES

- [1] *Brady B.H.D., Brown E.T.*: Rock Mechanics, London 1985.
- [2] *Goszcz A.*: Elementy mechaniki skał oraz tapania w polskich kopalniach węgla i miedzi. Wydawnictwo IGSMiE PAN, Kraków 1999.
- [3] *Goszcz A.*: Wybrane problemy zagrożenia sejsmicznego i zagrożenia tapaniami w kopalniach podziemnych. Wydawnictwo IGSMiE PAN, Kraków 2004.
- [4] *Jarosz J.*: Sposób wyznaczania zasięgu strefy spękań i lokalizacji odspojień w stropie wyrobisk górniczych za pomocą metody sejsmicznej. Studia, Rozprawy, Monografie nr 46, Wydawnictwo Centrum PPGSMiE PAN, Kraków 1996.

- [5] *Jarosz J.*: New Seismic Method for Localization of Delaminated Zone in the Underground Roadways. Materiały Ukraińsko-Polskiego Forum Górniczego 2004, 13–19 września 2004, Jałta, Krym, s. 308–314, wyd. Nacionalnoho Hirnyczoho Uniwersytetu, Dnipropetrowsk 2004.
- [6] *Ewing W.M., Jardetzky W.S., Press F.*: Elastic Waves in Layered Media. Mc Graw-Hill Book Company Inc, New York, Toronto, London 1957.
- [7] *Jakóbiec-Kwasnicka B., Marczak H.*: Wave Field Around Mine Roadways. Archiwum Górnictwa, t. 31, z. 4, s. 510–527, Katowice 1986.
- [8] *Kwasnicka B., Marczak H.*: The Thickness of Altered Zones in Tunnels Determined from Seismic Interference Waves. W: Journal EEG, vol. 3, Issue 2, 89–96, 1998.
- [9] *Krey T.*: Channel Waves as a Tool of Applied Geophysics in Coal Mining. Geophysics vol. XXVIII, no 5, part 1, 1963.
- [10] *Marczak H., Zuberek W.M.*: Geofizyka górnicza. Śląskie Wydawnictwo Techniczne, Katowice 1994.
- [11] Praca zbiorowa pod red. J. Dubińskiego, Z. Pileckiego i W. Zuberka: Badania geofizyczne w kopalniach. Wydawnictwo IGSMiE PAN, Kraków 2001.
- [12] *Salustowicz A.*: Mechanika górotworu. Skrypty Uczelniane AGH 39, Kraków 1960.