

Nina Fotieva, Nikolay Bulychev*, Andrey Sammal*, Petr Deev**

STRESS STATE AND BEARING CAPACITY OF SHALLOW TUNNEL LININGS UNDERGOING THE INFLUENCE OF NEARBY LOCATED BUILDINGS**

1. Introduction

Constructing the building or structure nearby the already existing tunnel may render a negative influence on the tunnel lining stress state and result in a substantial decrease of its safety factor. That is why it is necessary to evaluate that effect at planning the location of the erected building respectively to the tunnel to avoid a risk of the loss of the tunnel lining bearing capacity. With this aim a method allowing to determine the safety factor of a circular shallow tunnel lining undergoing the additional surface loads, has been developed at Tula State University [3]. The summarizing of this method for the design of shallow tunnel linings of an arbitrary cross-section shape (with a single axis of symmetry) is proposed in the paper presented. The method is also added by an approximate technique for taking the 3-D character of problems into account caused by limited sizes of buildings in the direction along the tunnel axis and by the location of several buildings on some distances between them in this direction. It gives a possibility to determine the stress state and evaluate the lining bearing capacity in different cross-sections along the tunnel axis.

2. The method of the design

The method is based on analytical solutions of corresponding plane problems of elasticity theory for semi-infinite linearly deformable medium simulating the soil (rock) mass, weakened by an opening of an arbitrary shape (with a single axis of symmetry) supported

* Tula State University, Tula

** The work is supported by grant of President RF on state support of leading scientific schools 1013.2003.5

by a ring from another material simulating the tunnel lining. The general design scheme is given in Figure 1.

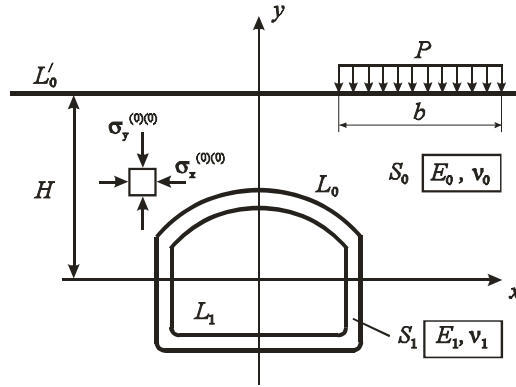

Fig. 1. The design scheme

Here the semi-infinite medium S_0 the mechanical properties of which are characterised by the deformation modulus E_0 and the Poisson's ratio ν_0 , simulates the soil (rock) mass. The ring S_1 from the material possessing the deformation characteristics E_1, ν_1 , simulates the lining of the tunnel located on the depth H .

The S_1 ring and S_0 medium undergo deformation together i. e. conditions of continuity of stresses and displacements vectors are satisfied on the L_0 contact line. The L_1 internal outline of the ring is free from loads.

The action of the rock (soil) own weight is simulated by a presence of initial stresses in the S_0 medium determined by formulae:

$$\begin{aligned}\sigma_x^{(0)(0)} &= -\lambda\gamma\alpha^*(H-y) \\ \sigma_y^{(0)(0)} &= -\gamma\alpha^*(H-y) \\ \tau_{xy}^{(0)(0)} &= 0\end{aligned}\tag{1}$$

where:

- γ — the rock unit weight,
- λ — the lateral pressure coefficient in an intact rock,
- α^* — the correcting multiplier introduced for an approximate registration of the influence of the l_0 distance from the lining being constructed up to the tunnel face.

That multiplier is determined by empirical formula [2]

$$\alpha^* = 0.6 \exp(-1.38l_0/R_0) \quad (2)$$

where R_0 is the average radius of the opening.

This problem being the basis of determining the lining stress state caused by the action of the soil own weight was described in the paper [4].

The weight of the building or structure on the surface is simulated by a load P uniformly distributed along an arbitrary part with the length b of the L'_0 boundary of the semi-plane.

There are two cases under consideration:

- 1) when the structure on the surface is being built after the tunnel construction,
- 2) when the tunnel is being constructed nearby the already existing structure.

In the latter case initial displacements in the soil mass caused by the P pressure before the tunnel driving are excluded from the boundary condition concerning the displacements, and the correcting multiplier α^* is being introduced into the calculation results.

The described problems of the elasticity theory have been solved with the application of the complex variable analytic functions theory [8], apparatus of the analytical continuation of complex potentials characterising the stress-strain state of the lower semi-plane out of a hole restricted by the L_0 outline, into the upper semi-plane across the straight boundary L'_0 [1], conform mappings and complex series. Such an approach allows to solve the problems considered with the aid of the iteration process [3, 4] applying in every approximation a solution of the problem for a non-circular ring supporting an opening in a whole plane at the boundary conditions including some additional members reflecting the influence of the straight boundary of the semi-plane, represented in the form of the Laurent's series the unknown coefficients of which are specified on the each step of iterations.

A special technique is offered for an approximate account of a 3-D character of the problems caused by limited sizes of buildings in the direction along the tunnel axis and by their spatial locations with respect to the tunnel.

The technique is based on a hypothesis that the relation k between stresses in the ring simulating the tunnel lining obtained from the solution of a 3-D problem, to the ones given by a plane problem, is approximately the same as a similar relation between vertical stresses appearing in the point of a solid half space (without tunnel) corresponding to the centre of the tunnel cross-section considered. The coefficient k may be determined on the basis of the Love's strong solution in way described in publication by V.B. Shvets *et al.* [9].

The above hypothesis has been confirmed to a certain degree by comparison of results obtained in this way with the data from physical modelling on the equivalent materials [6, 7] and 3-D numerical modelling [7]. The results of physical modelling have been obtained by D. Golitsynskiy, Yu. Frolov, V. Kavkazsky (St.-Petersburg Transport University, Russia), the numerical modelling has been carried out by J. Aldorf, E. Hrubesova, K. Voitasik (Tech-

nical University of Ostrava, Czech Republic) in the framework of the joint project with authors of this paper supported by the INTAS grant No 01-0647 — coordinator of the project is Dr. R.J. Fowell (Leeds University, UK).

The approximate approach proposed gives a possibility to evaluate the lining stress state in different cross-sections of the tunnel. A presence or erection of several building or structures on the surface including the ones located on some distances between them along the tunnel axis may also be considered.

On the basis of the solutions obtained the corresponding computer program has been developed allowing both the lining stress state and its safety factors to be determined.

With this aim after calculating the maximal compressive (negative) and tensile (positive) stresses on the internal lining cross-section outlines ($\sigma_{\theta \max}^{(c)}$, $\sigma_{\theta \max}^{(t)}$ correspondingly) the lining safety factor in a certain cross-section is determined by formula

$$k_s = \min \left(\frac{R_b}{|\sigma_{\theta \max}^{(c)}|}, \frac{R_{bt}}{\sigma_{\theta \max}^{(t)}} \right) \quad (3)$$

where:

$\sigma_{\theta \max}^{(c)}$, $\sigma_{\theta \max}^{(t)}$ — are correspondingly maximal compressive (negative) and tensile (positive) stresses along the internal outline of the lining cross-section considered caused by joint actions of the soil own weight and the surface loads;

R_b , R_{bt} — are resistances of the lining material to compression and tension.

3. Examples of the design

As an example the monolithic concrete tunnel lining is considered the form and sizes of which are shown in Figure 2.

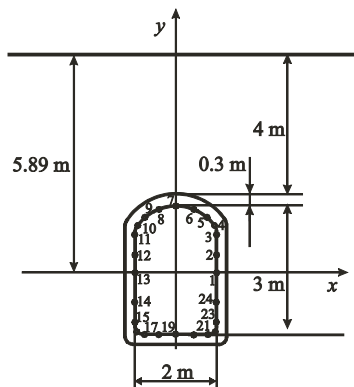

Fig. 2. The lining cross-section

The input data for the design are the following:

$$\begin{aligned}
 E_0 &= 500 \text{ MPa}, & \nu_1 &= 0.2, \\
 \nu_0 &= 0.3, & l_0 &= 1 \text{ m}, \\
 \lambda &= 0.43, & R_0 &= 1.67 \text{ m}, \\
 \gamma &= 0.02 \text{ NM/m}^3, & R_b &= 8.5 \text{ MPa}, \\
 E_1 &= 23,00 \text{ MPa}, & R_{bt} &= 0.75 \text{ MPa}.
 \end{aligned}$$

The lining undergoes the action of the soil own weight and the influence of three buildings the first and second of which existed before the tunnel driving and the third one is erected after the tunnel construction. The plan of building locations respectively to the tunnel axis is shown in Figure 3 (one grid side corresponds to 5 metres; the loads are equal to $P_1 = 0.075 \text{ MPa}$, $P_2 = 0.06 \text{ MPa}$, $P_3 = 0.1 \text{ MPa}$).

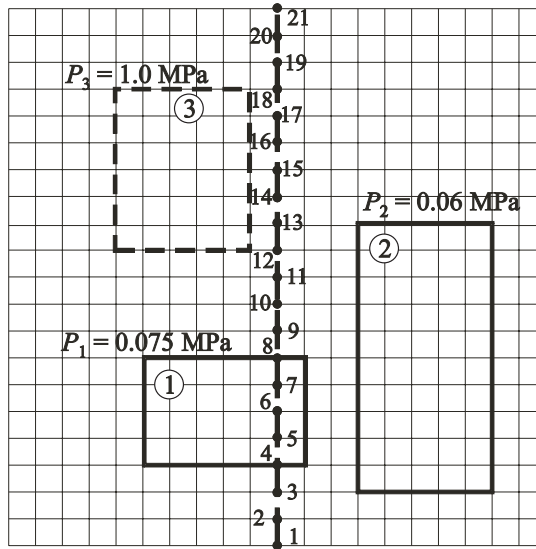

Fig. 3. Plan of building locations

Distributions of circumferential stresses (in MPa) appearing in points of the internal lining outline (numbers of points are given in Fig. 2) are shown in Figure 4; the curves 1, 2, 3, 4, 5 correspond to the lining cross-sections 6, 8, 11, 12 and 15 along the tunnel axis.

As it follows from Figure 4 the maximal circumferential stresses appear in the cross-section (compressive stresses — in the point 16 and the tensile ones — in the point 11).

The changing of stresses in points 11, 16, 19 of the lining along the tunnel length is shown in Figure 5 by curves 1, 2, 3 correspondingly.

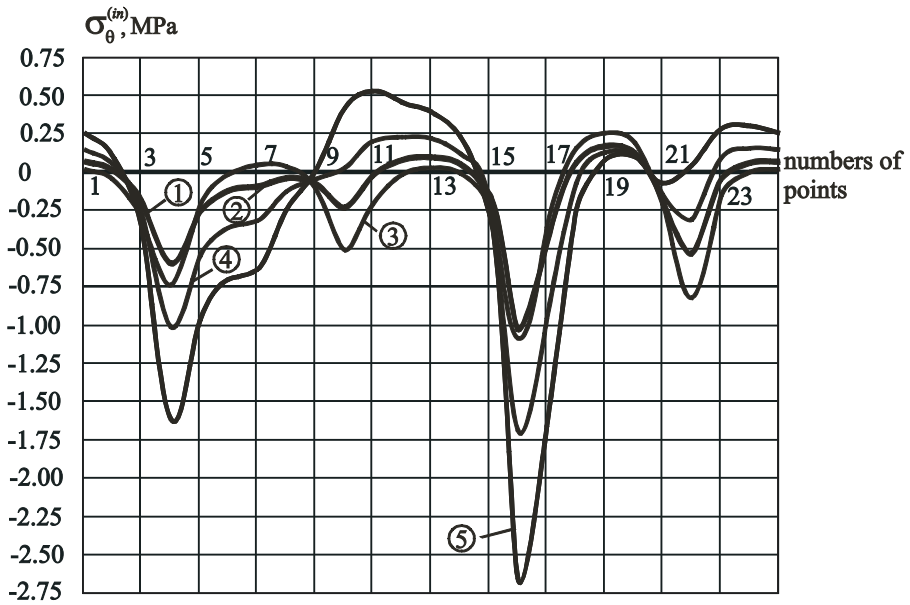

Fig. 4. Stresses $\sigma_{\theta}^{(in)}$ in points of the internal lining outline (see text)

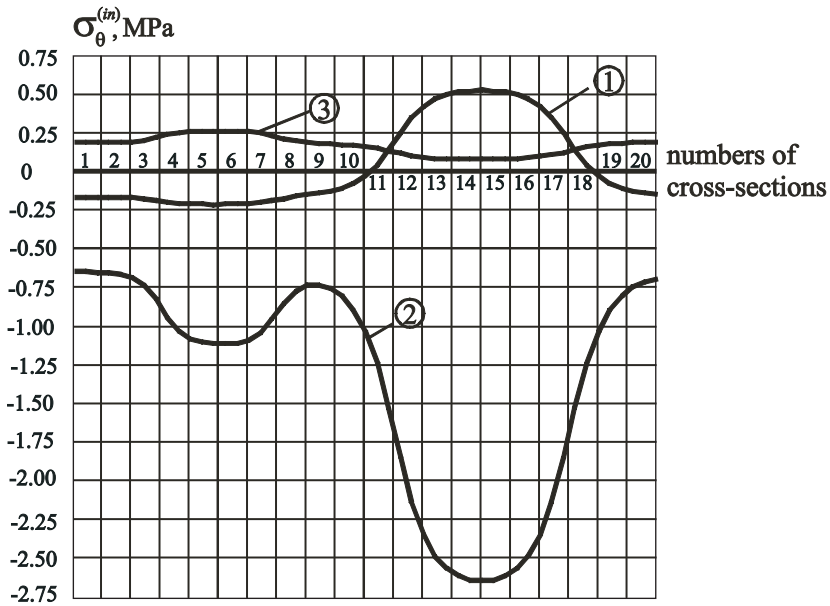

Fig. 5. Changing of stresses $\sigma_{\theta}^{(in)}$ in points 11, 16, 19 along the tunnel length (see text)

On the basis of the results obtained one can determine the safety factor of the lining, which is equal to 1.43 taking the erection of the third building into account.

Similar calculations carried out for case before the third building erection, result in the value of the lining safety factor $K = 2.86$. Therefore the erection of the third building reduces of the lining safety factor in 2.0 times.

Acknowledgements

The work has been carried out with the financial support by grant HIII-1013.2003.5 of Council on the State support of leading scientific schools of RF. This support is gratefully acknowledged.

REFERENCES

- [1] *Aramanovich I.*: Distribution of stresses in the elastic semi-plane weakened by the supported circular hole. Dokladi AN USSR, vol. 104, No 3, 1955, p. 372–375
- [2] *Bulychev N.*: On tunnel linings design in very soft soils. Proceedings of the International Conference, Tula 2002, p. 35–37
- [3] *Fotieva N., Bulychev N., Sammal A.*: Design of shallow tunnel linings. Proceedings of the ISRM International Symposium Eurock'96, Turin 1996, p. 677–680
- [4] *Fotieva N.N., Bulychev N.S., Sammal A.S., Deev P.V.*: Design of non-circular shallow tunnel linings under the action of the soil own weight. Kwartalnik AGH Górnictwo i Geoinżynieria, r. 27, z. 3–4, p. 283–288
- [5] *Fotieva N.N., Sammal A.S., Bulychev N.S.*: Decreasing the shallow tunnel linings safety factor due to erection of buildings on the surface. Proceedings of Underground Construction 2001 International Symposium, London 18–20 September 2001, p. 317–322
- [6] *Fotieva N.N., Sammal A.S., Bulychev N.S., Golitsynskiy D.M., Frolov Yu.S., Fowell R.J.*: Approximate registration of a 3-D character of the problem concerning the influence of a building on the stress state of a nearby located tunnel. Mathematical modeling and boundary problems. Proceedings of Russian Scientific Conference, part 1, Samara 2004, p. 242–245
- [7] *Fotieva N.N., Sammal A.S., Bulychev N.S., Golitsynskiy D.M., Frolov Yu.S., Kavkazsky V.I., Hrubesova E., Aldorf J., Voitasik K., Malik J., Kolcun A., Fowell R.J.*: Stress state of tunnel linings constructed in urban areas. Ukraińsko-Polskie Forum Górnictwa, Jalta, Krym 13–19 września 2004, p. 140–147
- [8] *Muskhelishvili N.*: Some Basic Problems of Mathematical Theory of Elasticity. Moscow, Nauka 1966
- [9] *Shvets V.B., Ginzburg L.K., Goldstein V.M., Kapustin V.K., Feklin V.I., Shvets N.S.*: Guide on Soils Mechanics and Dynamics. Kiev, Budivel'nik 1987