

Geometrical Accuracy of Threaded Elements Manufacture by 3D Printing Process

Grzegorz Budzik^{1*}, Tomasz Dziubek¹, Andrzej Kawalec¹, Paweł Turek¹, Anna Bazan¹, Mariusz Dębski¹, Jerzy Józwik², Przemysław Poliński³, Mateusz Kielbicki³, Łukasz Kochmański³, Mariusz Oleksy⁴, Józef Cebulski⁵, Andrzej Paszkiewicz⁶, Ivan Kuric⁷

¹ Faculty of Mechanical Engineering and Aeronautics, Rzeszów University of Technology, Al. Powstańców Warszawy 8, 35-029 Rzeszów, Poland

² Department of Production Engineering, Faculty of Mechanical Engineering, Lublin University of Technology, ul. Nadbystrzycka 36, 20-618 Lublin, Poland

³ Doctoral School of Engineering and Technical Sciences at the Rzeszów University of Technology, Al. Powstańców Warszawy 12, 35-959 Rzeszów, Poland

⁴ Faculty of Chemistry, Rzeszów University of Technology, Al. Powstańców Warszawy 6, 35-959 Rzeszów, Poland

⁵ Institute of Physics, University of Rzeszów, Al. Tadeusza Rejtana 16C, 35-310 Rzeszów, Poland

⁶ Faculty of Electrical Engineering and Computer Science, Rzeszów University of Technology, ul. Wincentego Pola 2, 35-021 Rzeszów, Poland

⁷ Department of Automation and Production Systems, Faculty of Mechanical Engineering, University of Žilina, Univerzitná 8215, 010 26 Žilina, Slovakia

* Corresponding author's e-mail: gbudzik@prz.edu.pl

ABSTRACT

Additive processes allow for almost any manufacturing of screw-threaded joint elements. However, this requires knowledge of the geometrical relationships of a threaded itself and the strength of materials from which the screw-threaded joint is made. Thanks to the development of research models and conducting tests related to dimensional accuracy and surface roughness, it was possible to test the models made by MEX process of ABS-M30, PLA, ABS, PETG materials, and PolyJet process from RGD720 polymer material. In the case of measurements carried out on the MarSurf XC20 system, the internal and external thread profile was obtained. Measurements of the surface roughness of the printed models were made using the Taylor Hobson TalyScan 150 profilometer. Based on the obtained surface, following the ISO 25178-2 standard, selected parameters were determined.

Keywords: additive manufacturing; threaded elements; surface roughness; computer measurement system.

INTRODUCTION

Computer aided modeling (CAD) of machine components and assemblies is the basis for manufacturing processes supported by numerical systems [1]. Implementation of the designer's concept is possible by making a model using available manufacturing techniques. Computer Numerical Control (CNC) methods [2, 3] are commonly used

in the industry, however, in order to minimize costs and increase the efficiency of the prototyping process and testing new solutions, Additive Manufacturing (AM) methods are increasingly used [4–6]. They allow for the formation of any geometry of models used in the automotive industry [7], aviation [8], medical industry [9]. Many scientific publications present the study of elements with complex shapes produced by additive

techniques, e.g. gear wheels or aircraft engine blades of gear wheels [10–13]. However, there is a lack of comprehensive tests concerning, among other things, screw-threaded joint. Screw threaded joints are significant. They are used primarily as movement connections in mechanisms that convert rotary into translational movement, e.g., machine tool drives, presses, or lifts.

The manufacture of screw-threaded elements carried out with additive techniques is a new approach for producing this elements. Presently, it is rarely approach to manufacturing fastening elements, which is not a popular topic in the available literature. The scope and results of the research, if they are conducted, are not published. The same applies to the approach to the development of the geometry of 3D-CAD models of screw elements. In the 3D-CAD modeling process, it is necessary to determine the fitting value of the screw-threaded joint manufactured with additive techniques [14]. This complex issue cannot be directly implemented based on the guidelines provided for standard screw thread manufacturing procedures [15, 16]. In connection with the specificity of additive techniques, this relationship translates into preparing the appropriate geometry of the basis models [17]. When models are made 3D printing process, there are differences between the nominal 3D-CAD model and the manufactured object [18, 19]. These differences result mainly from the subsequent hardening layers and the type of material used during 3D printing [20, 21]. In addition, each 3D printer has specific characteristics and requirements as to working conditions (environmental conditions, process temperature). The factors mentioned influence dimensional and geometrical errors and changes in the values of surface roughness parameters [22–26]. Their determination is necessary in order to obtain an appropriate screw-threaded joint. Thanks to the development of modern measurement systems, it is possible to precisely verify the accuracy of the macro and micro geometry [27] and elements manufactured using additive techniques. Verification of the manufactured product is most often carried out using contact coordinate measuring systems [28–33].

Additive processes allow for almost any manufacturing of screw-threaded joint elements. However, this requires knowledge of the geometrical relationships of a threaded itself and the strength of materials from which the screw-threaded joint is made. There is a noticeable lack

of detailed information relating to the torsional strength of additive-processed materials. The article presents the results geometric accuracy of the screw thread-nut M24 screw-threaded elements with a pitch of 3, manufactured of polymeric materials using MJ (PolyJet), and MEX (FDM and FFF) technologies.

MATERIALS AND METHODS

In this study, as a research model, the M24 screw thread-nut pair was designed with the nominal geometry and with the allowance values for two selected values [34], which were included in the nut models. The M24 screw was selected for testing, which is part of a larger research task in which bolts of this size were subjected to static strength tests in the torsion test. The diametrical parameters of the screw threads were adopted as nominal for all its configurations, and only the active screw thread length along with the length of the pin were modified.

Design research models

The modeling process, both for the screw thread and the nut, was carried out using solid modeling based on the preparation of a screw thread outline by dragging the profile along a helix [35]. Its geometry has been taken into account here, ensuring that the cutting profile exits the material at the end of the screw thread. The developed model was subjected to the parameterization process [36–38]. The primary purpose was to ensure a quick and practical possibility of changing the geometry of numerical models. For this purpose, the fundamental parameters shown in Figure 1 and 2 were adopted. It was assumed that:

- $d = 24 \text{ mm}$,
- $a = b + c$,
- $e = d = f$,
- $b = 50 \text{ mm}$.

For the presented dependencies, respectively, nominal screw thread models with a pin length of 50 mm. As a cooperating element, adopting the modeling methodology analogous to the thread, the CAD model of the nut was developed in three versions. However, in this case, the geometry of parts has been modified concerning the nominal value by assumed clearance values. For this purpose, the cutting profile

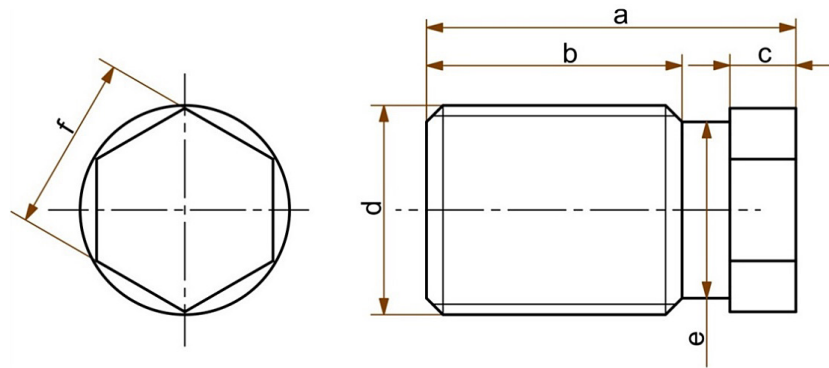

Fig. 1. Model drawing of the screw

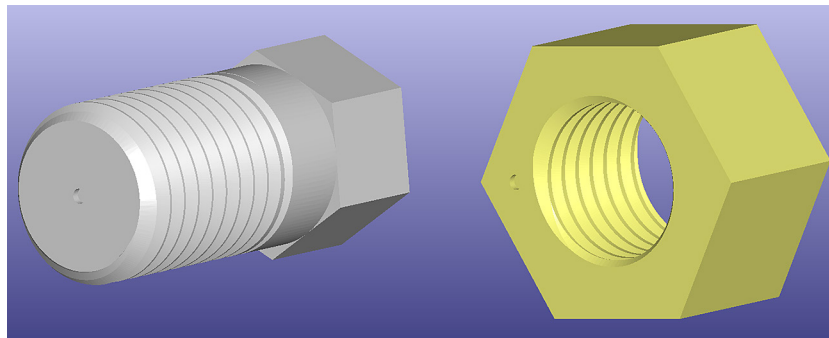

Fig. 2. View of 3D-CAD models of threaded elements

was shifted by 0.25 mm and 0.5 mm in the direction normal to the nut axis, and the internal thread diameter was increased by identical values. The other parameters remained unchanged. The models developed for production with the use of additive techniques were subjected to a tessellation process. Figure 3 shows the STL models made for different values of the tessellation parameters. Models with a tessellation accuracy of 0.005 mm were selected for the implementation of the prototypes (Fig. 3e). Other models do not meet the requirements of geometric accuracy requirements,

due to the size and shape of the triangles, which would make them visible on the model made in the incremental process.

The adopted values of parameters describing the geometry of 3D-CAD models were selected based on experience resulting from many years of practice in manufacturing with additive techniques and technical data defining the accuracy of the devices used. The developed geometry of the numerical models took into account the specific methodology of the screw thread modeling process, which cannot be directly implemented

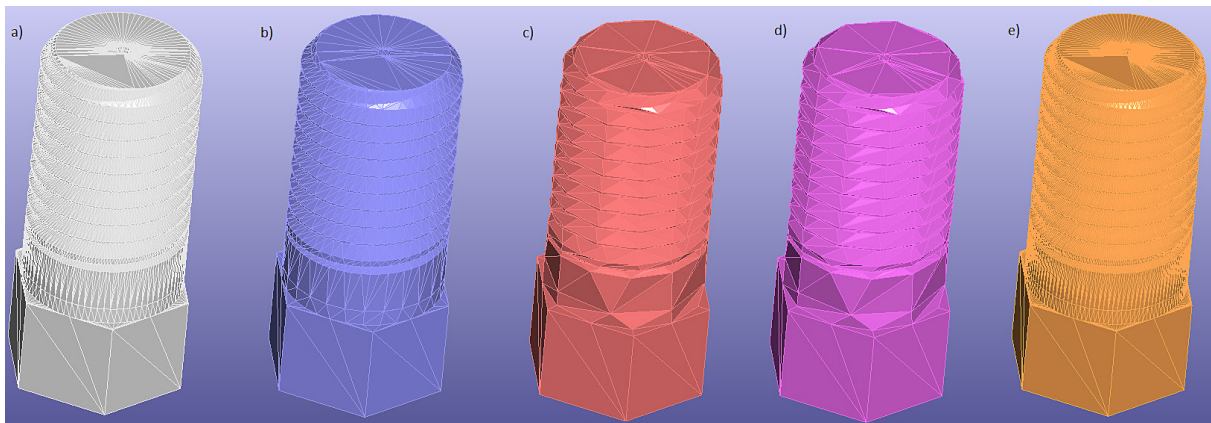

Fig. 3. STL models with a tessellation parameter value: a) 0,01 mm, b) 0,1 mm, c) 1 mm, d) 2 mm, e) 0.005 mm

Table 1. The additive manufacturing techniques

AM processes	AM technology	3D Printer	Commercial material name	Layer thickness	Status of material
Material Extrusion	FDM	Stratasys F170	ABS-M30	0.177 mm (nozzle diameter 0.4 mm)	Solid Based
	FFF	Prusa MK3s	PLA	0.150 mm (nozzle diameter 0.4 mm)	
			PETG		
Material Jetting	MJ	Objet Eden 260	RGD720	0.016 mm (Resolution x, y 600 × 600dpi)	Liquid Based

from the standard parameters of the screw thread resulting from its accuracy class related to screw threaded joint produced with the use of CNC methods [39, 40]. Based on the 3D-CAD models of the screw thread-nut pair geometry prepared in the presented manner, producing physical research models was carried out using selected additive techniques (Table 1).

Manufacturing a model using the FFF and FDM method consists of melting the material (filament) in a heated head, and then it is put on the worktable. The 3D printing process of models using the FFF technique was carried out on a Prusa MK3s printer. Three types of polymer materials were used: PLA (Fig. 3a), ABS, and PETG. PLA is a biopolymer classified as an aliphatic polyester. This material is characterized by quite good tensile strength and stiffness. ABS – or acrylonitrile - butadiene - styrene is a material obtained in butadiene polymerization and copolymerization of acrylonitrile with styrene with simultaneous grafting of the resulting copolymer on polybutadiene. Compared to PLA, it retains better hardness, impact, and abrasion resistance and good tolerance of high temperatures – because it retains its properties in the temperature range from

-20 to 80 °C. However, it is not resistant to ultraviolet rays. It crumbles after prolonged exposure to sunlight. It is also less stiff and more susceptible to shrinkage than PLA. PETG material combines the properties of both PLA and ABS, which means that it is relatively easy to print, and at the same time, mechanically robust. The softening point of PETG is around 80–85 °C, so it is not as high as in ABS but much higher than in PLA. So it can be said that PETG material can work at elevated temperatures.

The material RGD720 was used in the printing process of the models. RGD720 is a universal photopolymer resin that enables the creation of functional prototypes and parts for fit tests. This stiff material is perfect for conceptual modeling. This material provides high dimensional stability and surface smoothness.

As a result, models of screw threads and nuts were subjected to macro and micro geometry. Measurements of geometrical dimensions of screw threads and nuts were carried out on the MarSurf XC20 (Fig. 4). This device is a contact coordinate measuring system. It allows for effective measurement of the profile contour with an accuracy of up to one micrometer. The arm and



Fig. 4. Measure the nut profile using the MarSurf XC 20

the tip of the measuring system are selected depending on the properties of the measuring element. In the case of measuring the outline of the external and internal screw threads, an arm with a PCV 175-M/8 mm 5660 tip was used. In both cases, the measurement was performed with a resolution of 1 μm and the lowest possible speed - 0.20 mm/s. The contact tip made a linear movement along the given measurement section during the measurement, registering all irregularity of the surface on its path. The MarSurf XC20 was operated using the control panel and the software.

Measurements of the surface roughness of the printed models were made using the Taylor Hobson TalyScan 150 profilometer with a contact tip with a nose radius of 2 μm (Fig. 5). In the process of assessing the surface roughness parameters, the resolution along the X and Y axes was set to the minimum value of 5 μm. A single measured area was 4 mm x 1 mm. During the measurement, the lowest available measurement speed of 500 μm/s was used. Because samples were made using additives techniques, the most significant changes were observed in the direction perpendicular to the direction of the layers. Therefore the tests were carried out in this direction. The obtained data were analyzed in the MountainsMap software. In the process of determining the surface roughness parameters, form errors were first removed. Then, to separate the long-term components, a profile filter λc = 0.8 mm was used. The value of the sampling length was determined based on the procedure for periodic roughness profiles contained in the ISO 21920-3 standard [37]. Based on the obtained surface, following the ISO 25178-2 standard [38], selected parameters were determined:

- arithmetical mean of absolute values of ordinates within the defined area (A) – S_a :

$$S_a = \frac{1}{A} \iint_A |z(x, y)| dx dy \quad (1)$$

- root-mean-square of absolute values of ordinates within the defined area (A) – S_q :

$$S_q = \sqrt{\frac{1}{A} \iint_A z^2(x, y) dx dy} \quad (2)$$

- maximum peak height (S_p) – largest value of the peak height within the defined area
- maximum pit height (S_v) – largest value of the pit depth within the defined area
- maximum height (S_z) – the sum of the largest value of the peak height and the largest value of the pit depth within the defined area:

$$S_z = S_v + S_p \quad (3)$$

RESULTS

Based on the prepared test stands, results were obtained to assess the accuracy of the model geometry. In the case of measurements carried out on the MarSurf XC20 system, the internal and external thread profile was obtained. The reports presented in Figure 6 and 7 show the basic parameters defining the geometry of the external and internal thread for sample number 2, i.e.: major diameter of internal and external thread, pitch diameter of internal and external thread, minor diameter of internal and external thread, internal and external thread angle and pitch.



Fig. 5. Surface topography assessment using the TalyScan 150

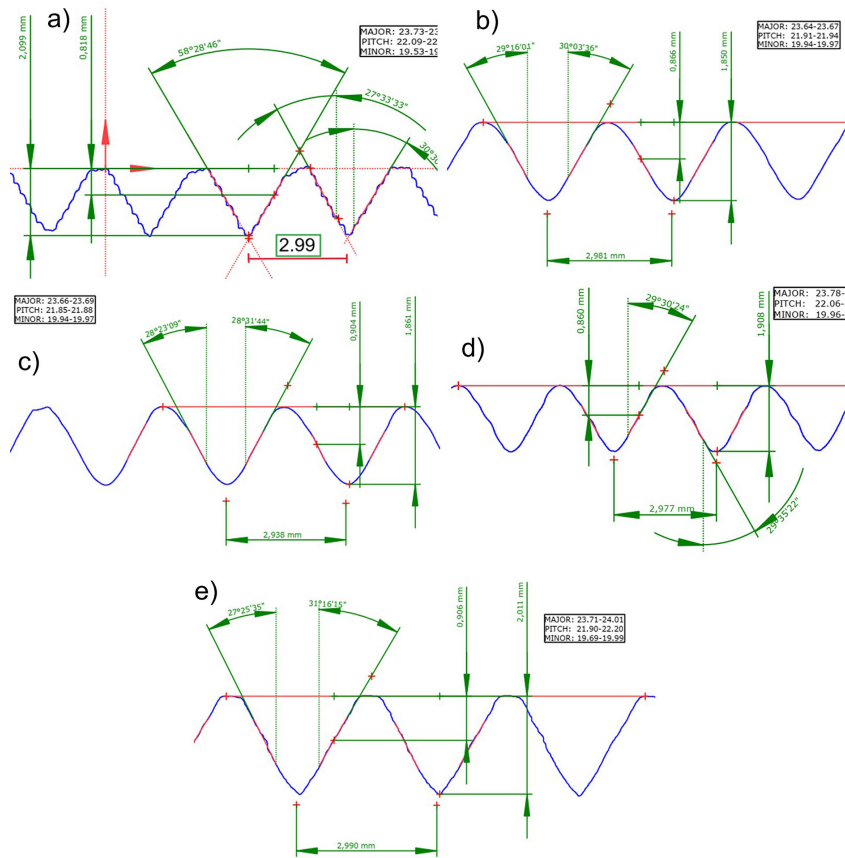

Fig. 6. Screw thread profile measurement results for: (a) ABS-M30; (b) PLA; (c) ABS; (d) PETG; (e) RGD720 material

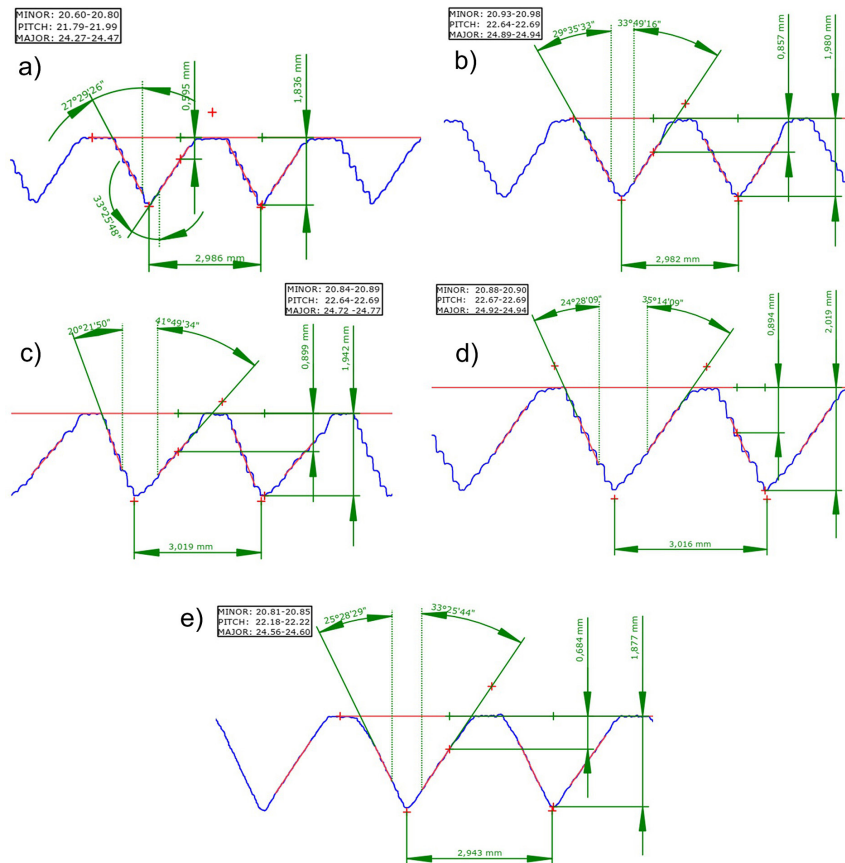

Fig. 7. Nut profile measurement results for: (a) ABS-M30; (b) PLA; (c) ABS; (d) PETG; (e) RGD720 material

Table 2. The obtained average values (five samples) of tolerance diameters for external and internal screw threads

Type of material	Tolerate diameter	Nominal value [mm] defined in ISO 724 for M24×3 screw thread	Average results [mm] of five measured samples	Proposal of the tolerance classes defined in ISO 965-3
ABS-M30	d	24	$24_{-0.050}^{0.025}$	5h
	d ₂	22.051	$22.051_{+0.009}^{+0.249}$	outside the recommended tolerances
	D ₂	22.051	$22.051_{-0.251}^{-0.060}$	outside the recommended tolerances
	D ₁	20.752	$20.752_{-0.142}^{+0.038}$	outside the recommended tolerances
PLA	d	24	$24_{-0.352}^{-0.310}$	4h
	d ₂	22.051	$22.051_{-0.125}^{-0.101}$	
	D ₂	22.051	$22.051_{+0.558}^{+0.609}$	outside the recommended tolerances
	D ₁	20.752	$20.752_{+0.188}^{+0.208}$	4H
ABS	d	24	$24_{-0.350}^{-0.302}$	5g6g
	d ₂	22.051	$22.051_{-0.191}^{-0.161}$	
	D ₂	22.051	$22.051_{+0.548}^{+0.609}$	outside the recommended tolerances
	D ₁	20.752	$20.752_{+0.068}^{+0.128}$	4H
PETG	d	24	$24_{-0.210}^{-0.180}$	5h
	d ₂	22.051	$22.051_{+0.002}^{+0.059}$	outside the recommended tolerances
	D ₂	22.051	$22.051_{+0.609}^{+0.639}$	outside the recommended tolerances
	D ₁	20.752	$20.752_{+0.088}^{+0.138}$	4H
RGD 720	d	24	$24_{-0.280}^{+0.000}$	5h
	d ₂	22.051	$22.051_{-0.141}^{+0.145}$	outside the recommended tolerances
	D ₂	22.051	$22.051_{+0.129}^{+0.139}$	4H
	D ₁	20.752	$20.752_{+0.056}^{+0.098}$	

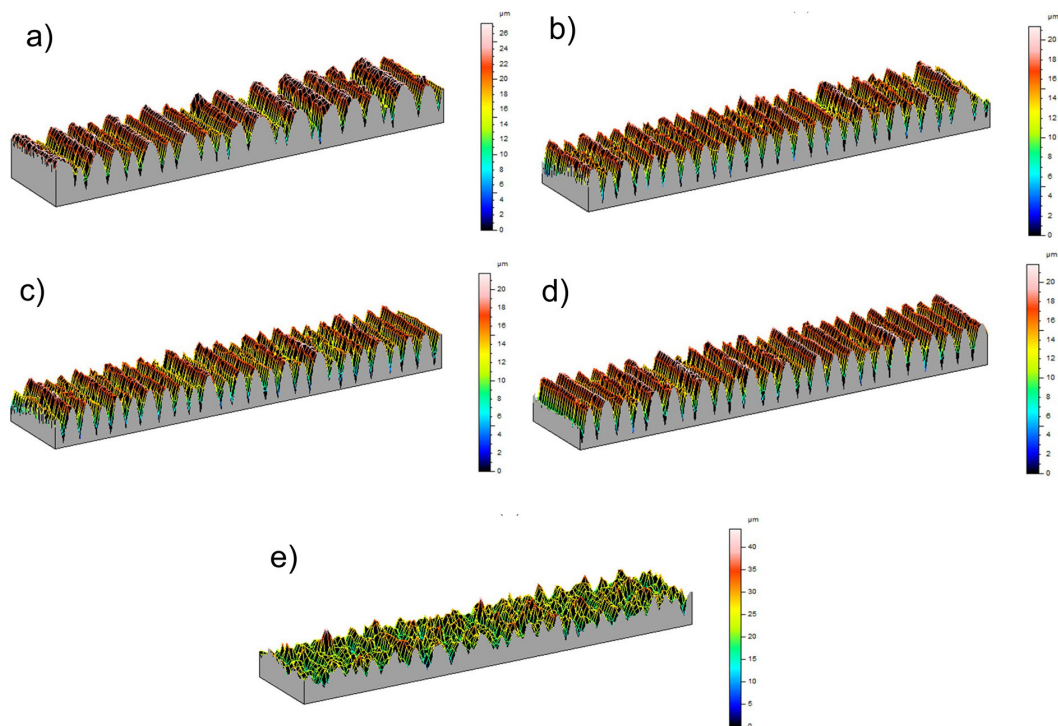

Fig. 8. Roughness measurement results for sample number 2 made of: (a) ABS-M30; (b) PLA; (c) ABS; (d) PETG; (e) RGD720 material

Table 3. Average roughness parameters of five samples

Type of material	Roughness parameters				
	Sa	Sz	Sq	Sp	Sv
ABS-M30	4.92	26.70	5.77	9.30	17.40
PLA	5.19	20.70	4.88	9.20	11.50
ABS	4.33	21.80	5.03	10.10	11.70
PETG	5.47	21.92	5.18	9.12	12.80
RGD 720	6.48	44.10	5.61	22.90	21.20

Based on the obtained averaged results, the measurements were compared with the normalized values contained in the ISO 724 and ISO 965-3 standards. The results are presented in Table 2.

Additionally, using the MountainsMap software, the results were generated, presenting an isometric view of the surface roughness with the determined parameters. The results presented in Figure 8 were made on the surface of the nut. The average results of five samples determined surface roughness parameters of the nut presented in Table 3.

CONCLUSIONS

Considering the results presented in Figures 6 and 7, the Material Extrusion and Material Jetting methods maintain similar pitch values. In the case of measuring the profile angle of the screw thread, all the techniques used gave a value lower than 60°. For the screw thread, the smallest value was 56°54'53" (ABS material), and the highest for 59°19'37" (PLA material). In the case of the nut, the results were more varied. The smallest value was 58°53'73" (RGD720 material), and the highest for 63°24'49" (PLA material). The difference in the obtained values of the thread profile angle may result from the applied orientation of the models in the 3D printer space. In the case of the screw thread, it was printed horizontally and the nut vertically (screw axis parallel to the working plane of the 3D printer, screw axis perpendicular to the working plane of the 3D printer). As a result of using a different print orientation for the nut, a greater slope of the outlined line is also noticeable especially in the case presented on Figure 7c and 7d. The Prusa 3D printer has the most significant problem maintaining the correct thread profile. As seen in the external thread profile analysis, the areas of the bottom and top land of the thread are significantly averaged. It is not affected by the selection of the type of

material but by the technical parameters of the 3D printer (Fig. 6b, c, and d). Additionally, the Prusa 3D printer is very sensitive to the change in the model's orientation in the working space. This can be seen in the context of mapping the profile of the external (Fig. 6b, c, d) and internal threads (Fig. 7b, c, d). Such significant changes are not noticeable in Stratasys F170 (Fig. 6a and Fig 7a) and Objet Eden 260 3D printers (Fig. 6e and Fig 7e). The PolyJet technology is the most precise in the visual quality of the thread profile. This is because when 3D printing with this technology, a layer thickness of 0.016 mm was used. This allowed us to achieve a more accurate reproduction of the thread profile, characterized by the lack of a visual aspect of the step, as is especially noted in the case of the Melted and Extruded techniques (Fig. 7a-7d). In the case of the Stratasys F170 printer, the partially correctly reproduced screw thread contour is also visible.

In the ISO 724 and ISO 965-3 standards, diameters d2 and d are tolerated in the external screw threads, while in the internal screw threads, D2 and D1. Both external and internal screw threads are tolerated into the material, taking the nominal screw thread contour as the zero line. Table 1 summarizes the values of tolerance deviations of diameters obtained during the measurement concerning the normalized values. They were determined based on the received maximum and minimum diameter measurement results carried out with the MarSurf XC 20 system. Considering the results in Table 1, eight tolerated diameters are outside the recommended tolerances. For diameters within the recommended specification limits, external screw threads are in the five-accuracy class (the exception is the thread printed from PLA material); internal screw threads are in the four-accuracy class. The diameters of the external and internal threads made of PLA material are most accurately reproduced (diameters are in four accuracy classes). The Stratasys F170

3D printer was the worst in mapping the tolerated diameters. According to the PN ISO 965-1 standard [41], three classes of threads are defined: fine (for precision threads, when a small fit tolerance is required), medium-fine (for general use), and coarse (in cases where threading difficulties may occur). To ensure the needed screw depth of finished parts, it is recommended to create fits like H/g, H/h, or G/h. If we analyzed only diameters within the recommended tolerance by PN ISO 965-3, mainly H/h type fits were obtained.

The visual analysis of the topography maps showed significant differences between the topography of the models produced with the melted and extruded (FDM, FFF) methods and the models made with the MJ method. In addition, models made with the MJ technique are characterized by a different shape of the pits compared to models made with the melted and extruded techniques. This is due to, among other things, the use of a different printing method and the type of material. In the case of the analysis of surface roughness parameters of Material Extrusion methods, the results are very similar despite the change in the material used. For the commercial Stratasys F170 printer, a slightly better surface finish was observed than the Prusa 3D printer. The Polyjet technique was the worst in terms of the quality of the surface roughness parameters. It may result from the applied printing option (Matt, not Glossy option was chosen) and the procedure removing the support material.

Acknowledgments

This publication was financed from the funds of the Ministry of Education and Science as part of the program Social Responsibility of Science / Excellent Science Name and module of the application: Excellent Science – Support for Scientific Conferences Synergy of Science and Industry, Challenges of the 21st Century, Science - Industry - Business.

REFERENCES

- Boboulos, M. CAD-CAM and Rapid Prototyping Application Evaluation. PhD & Ventus Publishing Aps, 2010.
- Gdula, M. Empirical Models for Surface Roughness and Topography in 5-Axis Milling Based on Analysis of Lead Angle and Curvature Radius of Sculptured Surfaces. *Metals* 2020, 10, 932. <https://doi.org/10.3390/met10070932>
- Thompson, M.K., et al. Design for Additive Manufacturing: Trends, opportunities, considerations, and constraints. *CIRP annals* 2016; 65: 737–760. <https://doi.org/10.1016/j.cirp.2016.05.004>
- Mazurkow, A., Sikorska-Czupryna, S. The Use of Reverse Engineering to Create FEM Model of Spiroid Gears. *Advances In Manufacturing Science And Technology* 2020; 44: 71–73. <https://doi.org/10.2478/amst-2019-0013>
- Baggi, E. Reverse engineering applications for recovery of broken or worn parts and re-manufacturing: Three case studies. *AdvEngSoftw* 2009; 40: 407–418. <https://doi.org/10.1016/j.advengsoft.2008.07.003>
- Leal, R., Barreiros, F.M.; Alves, L.; Romeiro, F.; Vasco, J.C.; Santos, M.; Marto, C. Additive manufacturing tooling for the automotive industry. *Int. J. Adv. Manuf. Technol.* 2017, 92, 1671–1676. <https://doi.org/10.1007/s00170-017-0239-8>
- Lecklider, T. 3D printing drives automotive innovation. *Eval. Eng.* 2017; 56: 16–20.
- Raja, V., Kiran J.F. *Reverse Engineering An Industrial Perspective*, Springer, New York, NY, USA, 2010.
- Ciocca, L. et al. A CAD/CAM-prototyped anatomical condylar prosthesis connected to a custom-made bone plate to support a fibula free lap. *Med BiolEngComput.* 2012; 50: 743–749. <https://doi.org/10.1007/s11517-012-0898-4>
- Turek, P., et al. Polymer materials used in medicine processed by additive techniques. *Polimery.* 2020; 65: 510–515. <https://doi.org/10.14314/polimery.2020.7.2>
- Garcia-Garcia, R., Gonzalez-Palacios, M.A. Method for the geometric modeling and rapid prototyping of involute bevel gears. *The International Journal of Advanced Manufacturing Technology.* 2018; 98: 645–656. <https://doi.org/10.1007/s00170-018-2246-9>
- Dziubek, T., Oleksy, M. Application of ATOS II optical system in the techniques of rapid prototyping of epoxy resin-based gear models. *Polimery.* 2017; 62: 44–52. <https://doi.org/10.14314/polimery.2017.044>
- Budzik, G., et al. Analysis of 3D printing parameters of gears for hybrid manufacturing. In: *AIP Conference Proceedings*. AIP Publishing LLC, 2018, 140005. <https://doi.org/10.1063/1.5034997>
- Ivanov, A.S., et al. Fatigue strength of threaded screws in submersible centrifugal pumps under a pulsating rupture force. *Russian Engineering Research.* 2015; 35: 571–574. <https://doi.org/10.3103/s1068798x15080067>

15. ISO 965-3:2021, ISO general purpose metric screw threads — Tolerances — Part 3: Limit deviations for screw threads;ISO: Geneva, Switzerland, 2021.
16. ISO 262:1998, ISO general purpose metric screw threads — Selected sizes for screws, bolts and nuts;ISO: Geneva, Switzerland, 1998.
17. ISO 724:1993, ISO general purpose metric screw threads — Basic dimensions;ISO: Geneva, Switzerland, 1993.
18. ISO 68-1:1998, ISO general purpose screw threads — Basic profile — Part 1: Metric screw threads;ISO: Geneva, Switzerland, 1998.
19. Leach, R.K., Bourell, D., Carmignato, S., Donmez, A., Senin, N., Dewulf, W. Geometrical metrology for metal additive manufacturing. *CIRP annals*. 2019; 68: 677–700. <https://doi.org/10.1016/j.cirp.2019.05.004>
20. Kechagias, J., Stavropoulos, P., Koutsomichalis, A., Ntintakis, I., Vaxevanidis, N. Dimensional accuracy optimization of prototypes produced by PolyJet direct 3D printing technology. *Adv. Eng. Mech. Mater.* 2014; 61–65. Available online: <http://inase.org/library/2014/santorini/bypaper/MECHANICS/MECHANICS-07.pdf> (accessed on 10 December 2020)
21. Chen, L., Lin, W.-S., Polido, W.D., Eckert, G.J., Morton, D. Accuracy, Reproducibility, and Dimensional Stability of Additively Manufactured Surgical Templates. *J. Prosthet. Dent.* 2019; 122: 309–314. <https://doi.org/10.1016/j.prosdent.2019.02.007>
22. Turek, P., Budzik, G., Przeszłowski, Ł. Assessing the Radiological Density and Accuracy of Mandible Polymer Anatomical Structures Manufactured Using 3D Printing Technologies. *Polymers*. 2020; 12: 2444. <https://doi.org/10.3390/polym12112444>
23. Gibson, I., Rosen, D.W., Stucker, B. *Additive Manufacturing Technologies*; Springer: New York, NY, USA, 2014.
24. Budzik, G., Woźniak, J., Paszkiewicz, A., Przeszłowski, Ł., Dziubek, T., Dębski, M. Methodology for the Quality Control Process of Additive Manufacturing Products Made of Polymer Materials. *Materials* 2021; 14: 2202. <https://doi.org/10.3390/ma14092202>
25. Kozior, T., Adamczak, S. Amplitude Surface Texture Parameters of Models Manufactured by FDM Technology. In *The International Symposium for Production Research*; Springer: Cham, Switzerland 2018; 208–217. https://doi.org/10.1007/978-3-319-92267-6_17
26. Fox, J.C., Moylan, S.P., Lane, B.M. Effect of Process Parameters on the Surface Roughness of Overhanging Structures in Laser Powder Bed Fusion Additive Manufacturing. *Procedia CIRP* 2016; 45: 131–134. <https://doi.org/10.1016/j.procir.2016.02.347>
27. Jamshidinia, M., Kovacevic, R. The influence of heat accumulation on the surface roughness in powder-bed additive manufacturing. *Surf. Topogr. Metrol. Prop.* 2015; 3: 014003. <https://doi.org/10.1088/2051-672x/3/1/014003>
28. Turner, B.N., Gold, S.A. A review of melt extrusion additive manufacturing processes: II. Materials, dimensional accuracy, and surface roughness. *Rapid Prototyp. J.* 2015; 21: 250–261. <https://doi.org/10.1108/rpj-02-2013-0017>
29. Kawalec, A., Magdziak, M. Usability assessment of selected methods of optimization for some measurement task in coordinate measurement technique. *Measurement* 2012; 45: 2330–2338. <https://doi.org/10.1016/j.measurement.2011.09.022>
30. Turek, P., Budzik, G., Sęp, J., Oleksy, M., Józwick, J., Przeszłowski, Ł., Paszkiewicz, A., Kochmański, Ł., Zelechowski, D. An Analysis of the Casting Polymer Mold Wear Manufactured Using PolyJet Method Based on the Measurement of the Surface Topography. *Polymers* 2020; 12: 3029. <https://doi.org/10.3390/polym12123029>
31. Saqib, S.; Urbanic, J. An experimental study to determine geometric and dimensional accuracy impact factors for fused deposition modelled parts. In *Enabling manufacturing competitiveness and economic sustainability* (pp. 293–298). Springer, Berlin, Heidelberg, 2012.
32. Pisula, J.; Dziubek, T.; Przeszłowski Ł. A comparison of the accuracy of bevel gear teeth obtained by means of selected RP techniques and the removal machining method. *Machine Dynamics Research* 2016; 40: 147–161. <http://mdr.simr.pw.edu.pl/index.php/MDR/article/view/200/182>
33. Turek, P., Budzik, G. Estimating the Accuracy of Mandible Anatomical Models Manufactured Using Material Extrusion Methods. *Polymers*. 2021; 13(14): 2271. <https://doi.org/10.3390/polym13142271>
34. Brajljih, T., Tasic, T., Drstvensek, I., Valentan, B., Hadzistevec, M., Pogacar, V., Acko, B. Possibilities of using three-dimensional optical scanning in complex geometrical inspection. *Strojnikovski Vestnik - Journal of Mechanical Engineering* 2011; 57: 826–833. <https://doi.org/10.5545/sv-jme.2010.152>
35. Bazan, A., Turek, P., Przeszłowski, Ł. Assessment of InfiniteFocus system measurement errors in testing the accuracy of crown and tooth body model. *Journal of Mechanical Science and Technology* 2021; 35: 1167–1176. <https://doi.org/10.1007/s12206-021-0230-z>
36. Michaud, M. *CATIA Core Tools: Computer Aided Three-Dimensional Interactive Application*. McGraw-Hill Education, 2012.
37. ISO 21920-3:2022 Geometrical Product Specifications (GPS) — Surface texture: Profile - Part 3: Specification operators ; ISO: Geneva, Switzerland, 2022.

38. ISO 25178-2:2022 Geometrical Product Specifications (GPS). In Surface Texture: Areal—Part 2: Terms, Definitions and Surface Texture Parameters; ISO: Geneva, Switzerland, 2022.
39. Bickford, J. Handbook of Bolts and Bolted Joints, CRC Press, Boca Raton, 1998.
40. Childs, T.H.C. (ed.) Mechanical Design. Theory and Applications (Third Edition), Butterworth-Heinemann, Oxford, 2021
41. ISO 965-1:2013 ISO general purpose metric screw threads – Tolerances – Part 1: Principles and basic data; ISO: Geneva, Switzerland, 2013.