

Henryk HOLKA<sup>1</sup>  
Tomasz JARZYNA<sup>1</sup>  
Maciej MATUSZEWSKI<sup>1</sup>  
Janusz MUSIAL<sup>1</sup>

## **MATERIAL RECYCLING OF TYRES BY WATER JET METHOD**

In this article there has been presented an innovative method of tire material recycling with the use of water jet technology including calculations of mass balance of the jetted water, velocity of the water flowing out of a nozzle, demand for power to drive the pump, or the energy consumption unit indicator. Moreover, an analysis of the dynamic impact of water jet on the tire has been made. Successive stages of the research, performed by the authors in order to develop the final model and construct the machine for tire recycling, have been described. In the final section of the paper there are calculation results and conclusions.

### **1. INTRODUCTION**

Used vehicle tyres have always been a huge ecological problem which fortunately we know how to fight with. Legal standards of the European Union forced on the member states initiatives aiming at recycling of used tyres [1],[9]. According to current standards 75% of used tyres is to be reprocessed in any manner and responsibility for meeting of such obligation is born by manufacturer of tyres. The cheapest method of reprocessing of tyres is so called power recycling, i.e. combustion. opposite to popular opinions it is very ecological, generating relatively small pollution. Combustion allows for obtaining huge volumes of heat as net caloric value of tyres is 32GJ/Mg and is close to net caloric value of coal. Combustion is performed in high temperature furnaces in cement plants, CHP and cellulose plants guaranteeing small amounts of pollution. Number of combusted tyres is ca. 60 to 75% of tyres intended for reprocessing. The remaining number of tyres we are forced to reprocess in other manner and it is so called material recycling based on deriving of rubber granulate from tyres.

There are two industrial methods of reprocessing tyres into granulate known:

- cryogenic method,
- mechanical method.

---

<sup>1</sup> University of Technology and Life Sciences, Faculty of Mechanical Engineering, Bydgoszcz, Poland

Cryogenic method is based on, in short, freezing tyres to temperature of ca.  $-85^{\circ}$ , and then breaking of frozen tyre into fine particles. First plants using such technology are founded. Mechanical methods are based on crushing tyres depending on needs into granulate of size from  $150\mu\text{m}$  to  $0,8\mu\text{m}$  and more. Final result is obtained in course of several operations from initial crushing to big particles to powdering during which granulate of required size is obtained. Meanwhile there are operations of separating rubber from wires and textile parts. Cost of the plant in automatic cycle can be as much as 5 million Euro. There are also smaller processing plants but every one has the problem of separating wire from rubber.

Application of rubber granulate is vast, for example the paving of leisure, sport objects or as filling for asphalt [2],[8].

The origin of research of authors on decomposition possibility of tyres with high pressure method is related with patent application from 2004, named: „Method for utilisation of tyres” and the patent granted in 2011 [3].

The research on this method has been carried out for about 3 years. It started with the literature review and finished with building a device in a semi-production scale. Scientific literature connected with cutting rubber with water and in particular decomposition of tyres with such method is very poor.

Descriptions of particular stages of the research are contained in works [5],[6],[7]. After having finished the research, a national and international patent application was elaborated on the basis of the obtained results and literature information [4].

This article is a supplementation of earlier works of the authors, and it presents explicitly the issue and the method which appears to be one that has been most precisely elaborated, both in Poland and Europe.

## 2. WATER JET METHOD

### 2.1. MASS BALANCE OF INJECTED WATER STREAM

Value of water nozzle outlet water stream was calculated based on the formula:

$$\dot{m} = \alpha \cdot \varepsilon \cdot F \cdot \sqrt{2 \cdot p \cdot \rho} \quad [\text{kg/s}] \quad (1)$$

where:

$\dot{m}$  - water mass stream [kg/s],

$\alpha$  - coefficient of resistance of flow through nozzle dependent on nozzle geometrical features,

$\varepsilon$  - number of expansions considering construction of water stream flowing through nozzle (for water  $\varepsilon \cong 1$ ),

F- surface of nozzle opening [ $\text{m}^2$ ],

$d$  – diameter of nozzle opening [m],

$p$  – pressure difference at nozzle inlet and outlet side [Pa],

$\rho$  - water density [ $\text{kg}/\text{m}^3$ ],  $\rho=1000\text{kg}/\text{m}^3$ .

From formula (1) nozzle consumption at various pressure differences  $p=100\text{MPa}$ ,  $150\text{MPa}$ ,  $200\text{MPa}$ ,  $250\text{MPa}$ ,  $300\text{MPa}$  and diameters  $d=1,00\text{mm}$ ,  $0,6\text{mm}$ ,  $0,4\text{mm}$  were calculated.

Calculation results are set in Table 1 and presented at Fig. 1.

Table 1. Nozzle consumption

No.	Pressure difference $p$ [MPa]	Consumption [ $\text{dm}^3/\text{min}$ ]					
		Nozzle diameter $d$ [mm]			Heads with 3 nozzles of diameter $d$ [mm]		
		1,0	0,6	0,4	1,0	0,6	0,4
1	100	14,74	5,31	2,36	44,22	15,93	7,10
2	150	18,06	6,50	2,89	54,18	19,50	8,67
3	200	20,85	7,51	3,33	62,55	22,53	10,0
4	250	23,31	8,39	3,73	69,93	25,17	11,19
5	300	25,54	9,19	4,08	76,62	27,57	12,24

In Table 1 there are also presented consumptions of heads with installed 3 nozzles of the same diameters.

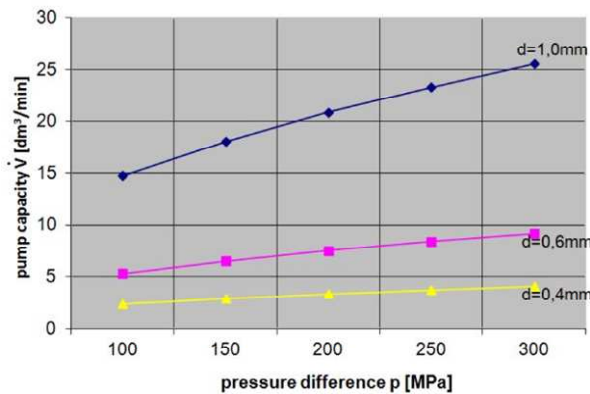

Fig. 1. Dependency of pump capacity on pressure difference

## 2.2. SPEED OF NOZZLE OUTLET WATER

Speed of nozzle flow rate:

$$v = \alpha \cdot \sqrt{\frac{2 \cdot p}{\rho}} \text{ [m / s] }, \quad (2)$$

where:

- $v$  – speed of water flow [m/s],
- $\alpha$  - coefficient of flow resistance,
- $p$  - pressure difference [Pa],
- $\rho$  - water density [kg/m<sup>3</sup>].

Calculation results are presented in Table 2.

Table 2. Values of water outlet from nozzle opening of diameter 1,00mm

Pressure [MPa]	100	150	200	250	300
Water speed [m/s]	313	383,4	442,7	495	542,2

The speed decreases with increase of distance of water stream from nozzle proportionally to quotient  $1/l^2$  – where  $l$  – distance from nozzle outlet.

### 2.3. POWER DEMAND FOR DRIVE OF PRESSING PUMP FOR WATER TO INJECTION NOZZLES

Power for drive of water pressing pump to injection nozzles was calculated from the formula:

$$N = \frac{p \cdot \dot{V}}{\eta} [kW] \quad (3)$$

where:

- $N$  – demand of power for pump drive [kW],
- $p$  – water pressure in pump pressing duct [kPa],
- $\dot{V}$  -stream of volume of pressed water [m<sup>3</sup>/s],
- $\eta$  - pump general efficiency equal product of volumetric  $\eta_w$  and mechanical efficiency  $\eta_m$ ,  $\eta = \eta_w \cdot \eta_m$ .

For pumps used in installations for water stream cutting of high pressure  $\eta=0,98$ . Power demand for water pressing pump was calculated based on formula 3, and results are presented on graph (Fig. 2).

Power demand increases very quickly with increase of pressure for nozzle of diameter 1,0mm. For nozzles of diameters 0,6mm and 0,4mm the increase is smaller. On the graph in very close proximity there are dependency lines of power demand from pressure value for

individual nozzle of diameter  $d=1,0\text{mm}$  and for head with a set of three nozzles of diameters  $d=0,6\text{mm}$  ( $3xd=0,6\text{mm}$ ).

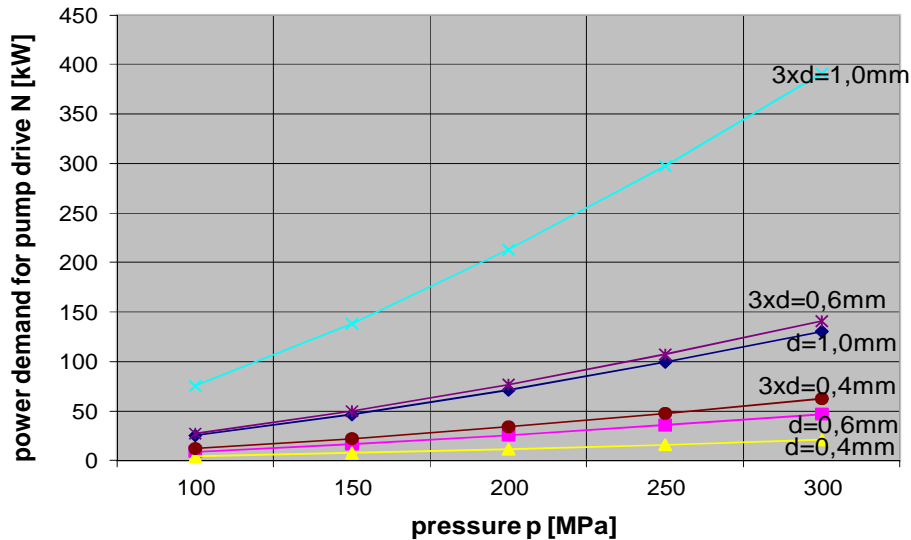

Fig. 2. Dependency of power demand for pump drive on pressure

Due to the effect of tyre processing and aiming at reduction of power consumption for pump drive in tests systems of  $3xd=0,6\text{ mm}$  and  $3xd=0,4\text{ mm}$  should be used.

#### 2.4. POWER CONSUMPTION AND ANALYSIS OF POWER IMPACT OF HIGH PRESSURE WATER STREAM ON VEHICLE TYRE

Power consumption of vehicle tyres decomposition was discussed on the basis of factor  $e$  of unit consumption of power expresses as  $\frac{kWh}{Mg}$  and calculated from formula:

$$e = \frac{N \cdot \tau}{3600 \cdot m_o} \left[ \frac{kWh}{Mg} \right] \quad (4)$$

where:

$N$  – power required for drive of water pressing pump for injection nozzles [kW],

$\tau$  - duration time of tyres decomposition operation [s],

$m_o$  – mass of tyres subject to decomposition [Mg].

Value of unit factor of energy consumption was calculated based on data obtained from initial tests over decomposition of vehicle tyres. Accepted for calculations the values of time  $\tau$ , and parameters of operation of decomposition of tyres and value of coefficient  $e$

are presented in Table 3. Decomposition tests were conducted with use of vehicle tyres manufactured by the facility in Dębica. These were passenger vehicle tyres marked with symbol 175/70/R13. Tyre mass equalled  $m_o=6\text{kg}$ .

Table 3. Values of unit factor of power consumption  $e \left[ \frac{\text{kWh}}{\text{Mg}} \right]$

No.	Pressure p [MPa]	System of individual nozzles			Heads with 3 nozzles		
		Operation time $\tau=240\text{s}$			Operation time $\tau=60\text{s}$		
		Nozzle diameters [mm]			Nozzle diameters 3xd [mm]		
		1,0	0,6	0,4	3x1,0	3x0,6	3x0,4
1	100	278,44	100,33	44,5	208,55	75,25	33,42
2	150	511,88	184,22	81,83	383,94	138,17	61,42
3	200	787,99	283,77	125,77	531,01	212,85	94,34
4	250	1101,10	396,32	176,61	825,89	297,27	132,09
5	300	1447,80	520,80	231,22	1085,92	390,69	173,43

Water stream outlet from nozzles of high speed is a carrier of energy causing decomposition of processed vehicle tyre. Liquid movement describes the basic equation of Navier – Stokes referring to flow of viscous and compressible. The equation expressed in vectors for the case of set movement where speed local derivative  $v$  of liquid equals zero  $\left( \frac{\partial v}{\partial \tau} = 0 \right)$  has the form of:

$$\frac{d\bar{v}}{d\tau} = F_m - \frac{1}{\rho} \cdot \text{grad} \rho + \nu \cdot \nabla^2 \bar{v} + \frac{1}{3} \nu \cdot \text{grad}(\text{div} \bar{v}) \quad (5)$$

where:

- $F_m$  – mass powers [N],
- $\nu$  - kinematic viscosity [ $\text{m}^2/\text{s}$ ],
- $\tau$  - time [s],
- $p$  – pressure [Pa],
- $v$  – speed [m/s].

It illustrates complex nature of water movement and values influencing such movement in injected stream. The equation is unsolvable for the discussed flow case. Discussing the impact of high pressure water stream approximate dependencies specified from tests were used. Water stream outlet from nozzles creates turbulent free stream presented on drawing on Fig. 3.

Free stream consists of core of initial section length  $l_1$  and bordering layer. At every point of core the liquid has speed equal initial speed  $v_o$ . In horizontal cross-section of bordering layer there is speed gradient towards axis  $y$ ,  $\frac{\partial v_x}{\partial y} \neq 0$ . Speed component on

axis  $y$ ,  $v_y$  is much smaller than speed component on axis  $x$  and can be neglected which allows for treatment of flow as a form of free stream as single direction flow.

Length of initial section  $l_1$  is calculated from formula:

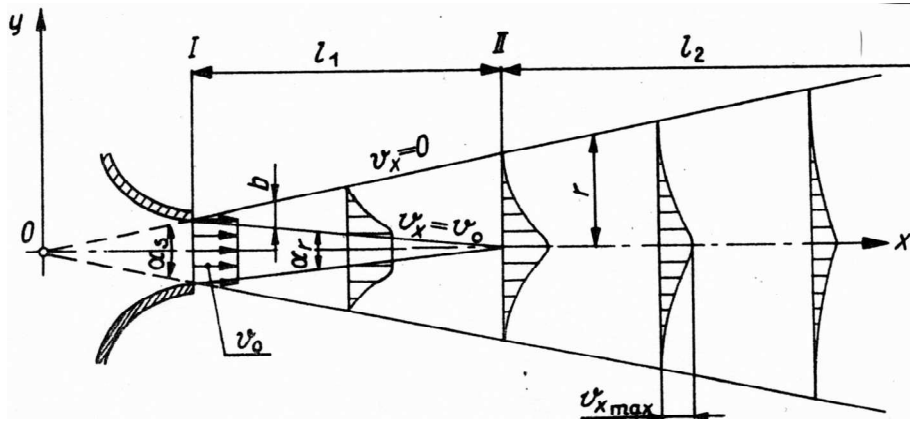

Fig. 3. Turbulent free stream; I initial cross-section, II intermediate cross-section,  $l_1$  – initial section,  $l_2$  – main stream core

$$l_1 = 0,67 \cdot \frac{r_o}{a} [m], \quad (6)$$

where:

$r_o$  – radius of nozzle outlet [m],

$a$  – experimental coefficient for nozzles of circular cross-section  $a=0,066-0,076$ ; higher values of  $a$  correspond to higher initial turbulences of stream.

Initial section length for example was calculated for nozzle of diameter  $d=1,0\text{mm}$  ( $r_o=0,5\text{mm}$ ) taking value  $a=0,07$ .

## 2.5. ANALYSIS OF DYNAMIC IMPACT OF INJECTED JET ON TYRE

Considering dynamic impact of injected stream on tyre surface it was assumed that:

- water forms free stream,
- flow is set and of single direction,
- impact of mass powers and environmental powers was neglected,
- tyre surface is smooth,
- stream has normal direction to tyre surface.

Water stream after crushing of rubber layer is subject to partial damming on reinforcement wires. Part of stream flows through slots between reinforcement wires and it spreads the rubber and cotton textile of inner tyre layer, and second part of stream damming on wires changes the direction of flow, its speed and pressure. As a result of stream impact

in static direction to reinforcement layers at width of ca. 5mm there is a separation of rubber from tyre wires. The phenomenon was confirmed in initial tests conducted during realization of the hereby scientific project. During the test of parallel circumferential cutting of rubber protector totally separated from tyre rubber strip was obtained of width ca. 10mm (Fig. 7).

Impact of free stream on tyre tread is presented on drawing on Fig. 4.

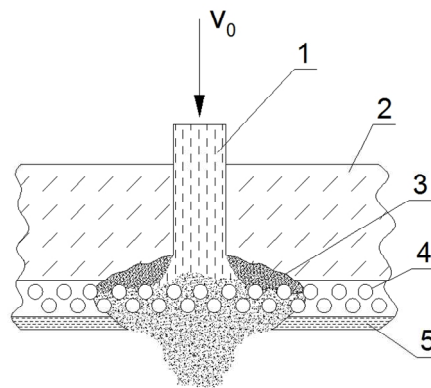

Fig. 4. Drawing of impact of free stream nozzle injected on tyre tread: 1 – injected water jet, 2 – rubber layer of tyre tread, 3 – area of rubber crushing as a result of partial damming of water stream on tyre reinforcement wires, 4 – tyre reinforcement wires, 5 – inner tyre layer (textile and rubber)

Power of water free stream reaction was calculated from dependency:

$$R_n = \dot{m} \cdot v [N], \quad (7)$$

where:

$R_n$  – reaction of free stream [N],

$\dot{m}$  – water mass stream [kg/s],

$v$  – average stream speed [m/s].

As an example value of reaction of free stream on tyre tread surface was calculated accepting for nozzle diameter  $d=1,0$  mm water pressure  $p=200$ MPa. At such pressure water mass Stream has value  $\dot{m}=20,85$  kg/min $\cong 0,35$ kg/s, and stream speed  $v=442,7$ m/s. Reaction of free stream on surface of tyre tread has value of:

$$R_n = 0,35 \frac{kg}{s} \cdot 442,7 \frac{m}{s} = 153,84N \quad (8)$$

Caused by its impact unit load on tread surface equals:

$$\sigma_d = \frac{R_n}{F} [Pa], \quad (9)$$



where:

$\sigma_d$  – unit load [Pa],

F – surface of operation of water free stream  $F = \frac{\pi \cdot d^2}{4}$  [m<sup>2</sup>].

Value of unit load is:

$$\sigma_d = 195974522,3 Pa = 196 MPa$$

Reaction of free stream on tyre tread surface has such high value that it is necessary to support the tyre on its inner side in order to protect it against bending at place of water impact. Bending of tyre surface at location of injected water drop diminishes the effect of tread cutting as the distance of nozzle from tyre increases.

### 3. EXPERIMENTAL TESTS

Experimental tests were conducted on passenger vehicle tyres. Without any knowledge on impact of water stream on tyre the best processing methods were searched for. The following text describes in chronological order individual stages of tests closing the authors to final result.



Fig. 5. First attempts of water impact on tyre with various systems of tyre drive



Fig. 6. Horizontal cut with single stream



Fig. 7. Circumferential cut with single stream

Initial tests showed that single water stream flushes out rubber and textile fractions leaving metal shield. The results seemed promising and were the basis for further work. Tyre bending under water impact, theoretically proven, caused that further tests were conducted on flat spread tyre (Figs. 8, 9). Test results are presented on Fig. 9.

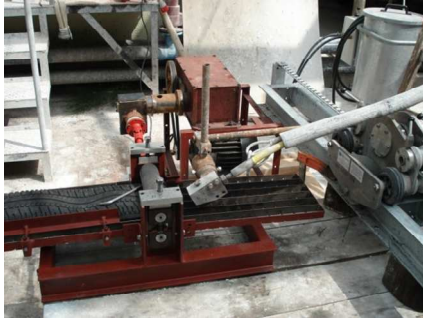

Fig. 8. Tests on flat tyre



Fig. 9. Result of impact of single stream on flat spread tyre



Fig. 10. Cut with head with 3 nozzles on flat tyre



Fig. 11. Impact results

The next stage was to use rotating heads with 3 nozzles (Fig. 10). Efficiency of process with use of heads was so high that in further tests the focus was only on this processing system and improvement of position. Figure 11 shows perfectly cleaned surface. Figure 12 presents model of machine used for tyres processing.

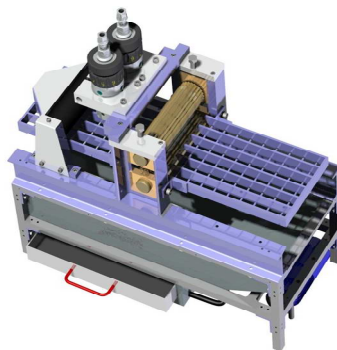

Fig. 12. Machine for tyres recycling with water use

#### 4. TEST RESULTS

As a result of impact of water from 3 nozzle injection head ideally clean wires were obtained (Fig. 11). During the tests it was stated that the best results were obtained at processing of flat spread tyre [5]. Due to small sizes the obtained device is compact and mobile. Due to process water demand it was stated that the most optimum is to use nozzles of diameters  $d=0,4\div 0,6$ mm. Also value of unit consumption of power was calculated upon application of head with 3 nozzles of diameters  $d=0,4$ mm and at pressure of injected water  $p=200$ MPa, which was 188kWh/1Mg. It turned lower than the factor for mechanical method. It was also stated that the lowest pressure which can be applied at lower efficiency is  $p=150$ MPa. Moreover, average value of sizes for flushed rubber particles was specified and it was ca. 140 $\mu$ m. As the device is very small easy increase of output is possible by installation of additional positions. The disadvantage of the solution is high water demand, hence the necessity of installation of big tanks with filter and closed circuit. Obtained results were the basis for granting international patent [4].

#### 5. CONCLUSIONS

1. Power demand in water-jet method is lower than in mechanical tyre shredding.
2. Crushed rubber particles do not contain wire particles being the advantage of the method.
3. High demand of water determines a secondary circuit.
4. It should be stressed that the proposed method is the only tested and completed method in Poland and Europe.

#### REFERENCES

- [1] BEUERKING VAN P.J.H., JANSSEN M.A., 2004, *Trade and recycling of used Tyres In Western and Eastern Europe – Resources*, Conservation and Recycling, 33, 235-265.
- [2] GARBASZ B., GARBALINSKA H., 2007, *Using tyres in road surfaces*, Recycling, 5/77.
- [3] HOLKA H., 2004, Patent applications, *Method of utilisation of tyres*, P.371170.
- [4] HOLKA H., JARZYNA T., 2010, Patent applications, *Method of retrieval of gum from used car tires and installation for its Application*, P.392151.
- [5] HOLKA H., JARZYNA T., 2008, *Decomposition and material recycling method for car*, Inżynieria i Aparatura Chemiczna, 5, 11-12, (in Poland).
- [6] HOLKA H., JARZYNA T., 2010, *Energetic aspects of tires' decomposition using water-jet methods*, Inżynieria i Aparatura chemiczna, 5, 43-44, (in Poland).
- [7] HOLKA K., JARZYNA T., 2011, *Use of a three-nozzle head spray in the water-jet method for car tires' decomposition*, Inżynieria i Aparatura Chemiczna, 3, 29-30, (in Poland).
- [8] PEHLKEN A. A., MULLER D. H., 2004, *Using information of the separation process of recycling scrap tires for process modelling – Resources*, Conservation and Recycling, 33, 235-265.
- [9] RADZISZEWSKI P., OLDAKOWSKA E., 2008, *Directions for management of used vehicle tyres in Poland and the European Union – legal situation*, – Scientific Papers of the Bialystok University of Technology, Construction, 32.