

AGNIESZKA KIJÓ-KLECZKOWSKA*

RESEARCH ON COAL-WATER FUEL COMBUSTION IN A CIRCULATING FLUIDIZED BED

BADANIE SPALANIA ZAWIESINOWYCH PALIW WĘGLOWO-WODNYCH W CYRKULACYJNEJ WARSTWIE FLUIDALNEJ

In the paper the problem of heavily-watered fuel combustion has been undertaken as the requirements of qualitative coals combusted in power stations have been growing. Coal mines that want to fulfill expectations of power engineers have been forced to extend and modernize the coal enrichment plants. This causes growing quantity of waste materials that arise during the process of wet coal enrichment containing smaller and smaller under-grains. In this situation the idea of combustion of transported waste materials, for example in a hydraulic way to the nearby power stations appears attractive because of a possible elimination of the necessary deep dehydration and drying as well as because of elimination of the finest coal fraction loss arising during discharging of silted water from coal wet cleaning plants. The paper presents experimental research results, analyzing the process of combustion of coal-water suspension depending on the process conditions. Combustion of coal-water suspensions in fluidized beds meets very well the difficult conditions, which should be obtained to use the examined fuel efficiently and ecologically. The suitable construction of the research stand enables recognition of the mechanism of coal-water suspension contact with the inert material, that affects the fluidized bed. The form of this contact determines conditions of heat and mass exchange, which influence the course of a combustion process. The specificity of coal-water fuel combustion in a fluidized bed changes mechanism and kinetics of the process.

Keywords: Coal-water fuels; Coal-mule; Biomass; Combustion in Circulating Fluidized Bed

W pracy omówiono problematykę spalania wysoko zawodnionych paliw, która nabiera coraz większego znaczenia w miarę wzrostu wymagań jakościowych węgla spalanych w elektrowniach. Kopalnie węgla kamiennego, chcąc spełnić oczekiwania energetyków, zmuszone zostały do rozbudowy i unowocześnienia zakładów wzbogacania węgla. Powoduje to wzrost ilości odpadów powstających w procesie mokrego wzbogacania zawierających coraz mniejsze podziarna. W tej sytuacji koncepcja bezpośredniego spalania wspomnianych odpadów, transportowanych np. hydraulicznie do pobliskich elektrowni wydaje się atrakcyjna, zarówno ze względu na możliwość eliminacji konieczności głębokiego odwadniania i suszenia, a także likwidacji strat najdrobniejszych frakcji węgla, przy zrzuceniu zamulonych wód z zakładów wzbogacania. W pracy zaprezentowano wyniki badań eksperymentalnych, analizujących proces spalania zawiesiny w-w w zależności od warunków prowadzenia procesu. Spalanie zawiesin w-w w warstwie fluidalnej bardzo do-

* TECHNICAL UNIVERSITY OF CZESTOCHOWA, ARMII KRAJOWEJ 21, 42-201 CZESTOCHOWA, POLAND; E-mail: kijo@kkt.pcz.czyst.pl

brze spełnia trudne warunki, jakie należy uzyskać, aby sprawnie i ekologicznie wykorzystać rozpatrywane paliwo. Odpowiednia konstrukcja stanowiska badawczego umożliwiła rozpoznanie mechanizmu kontaktu zawieszony w-w z materiałem inertnym, stanowiącym warstwę fluidalną. Od formy tego kontaktu zależą bowiem warunki wymiany ciepła i masy, które decydują o przebiegu procesu spalania. Jak wykazano, specyfika spalania zawieszony w-w w warstwie fluidalnej zmienia mechanizm i kinetykę procesu.

Słowa kluczowe: Paliwa węglowo-wodne; Muł węglowy; Biomasa; Spalanie w cyrkulacyjnej warstwie fluidalnej

1. Introduction

Combustion of fuels in circulating fluidized beds (CFB) takes place in different conditions than the conditions of traditional furnaces. It results from the specificities of dispersion arrangement. One of the chapters of the paper has been devoted to the specificity of fuel combustion in a fluidized bed (Gajewski & Kijo-Kleczkowska, 2004, 2007; Gajewski et al., 2009; Kijo-Kleczkowska, 2011a). From the circulating movement of the material in the contour of the furnace with the fluidized bed (the combustion chamber, the cyclone, the system of material return) results the occurrence of cyclic combustion of fuel particles (Fig. 1).

In papers (Gajewski, 2005-2008; Kijo-Kleczkowska, 2011b) it has been shown, that the process of repeated heating, ignition, cooling and extinction causes a slight shift of the mechanism of fuel combustion in the kinetic direction. It is connected with the lowering of the average fuel temperature. The results of experiments prove a slight lengthening of real time of fuel combus-

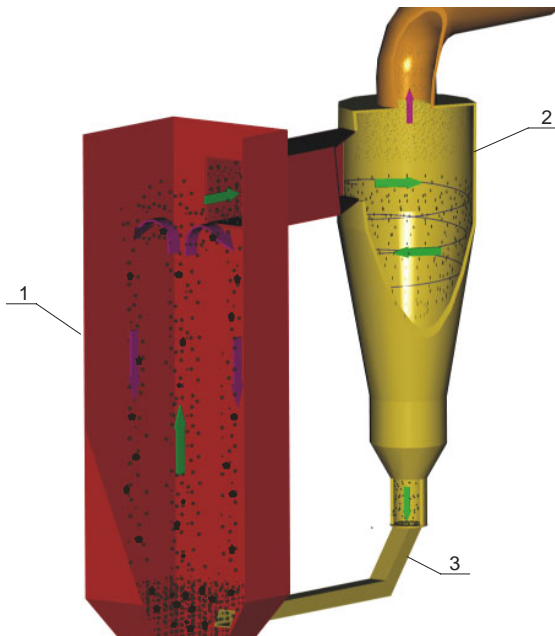

Fig. 1. Average movement of fuel particles in the boiler with a circulating fluidized bed
1 – combustion chamber, 2 – cyclone, 3 – system of material return
— internal circulation; — contour circulation

tion as a consequence of a cyclical interruption of combustion (in comparison to combustion in a stream of air), especially in the range of high values of fuel moistness, high temperatures in the combustion chamber and higher gas flow velocity.

According to papers (Basu & Fraser, 1991; Grace et al., 1997), in the boiler with a circulating fluidized bed, the characteristic flow of the inert material shapes different hydrodynamic properties of particular areas in the contour of the furnace. The fluidized bed is made of polydispersal mixture of inert materials (fuel, quartz sand, ash and limestone stone) in a wide range of granulation and density. The value of gas flow velocity in such diversified material of the fluidized bed affects significantly its behavior as well as the process of mixing of particles and their segregation. According to papers (Basu & Fraser, 1991; Grace et al., 1997) the increase of gas flow velocity leads to the changes of state of the motionless fluidized bed from the blister state, the turbulent state, the quick state to pneumatic transportation. At first, it causes intensification of mixing processes which results from the increase of gas-blisters, leading to enlargement of the bed layer height. Further increase of air flow velocity makes the particles of the inert material fill all volume of the column. The intensification of particles convection follows, attaining the level when the particles are caught at the outlet of the column and re-circulated to the bed. Otherwise, all mass of the inert material that makes the fluidized bed will be lifted from the combustion chamber. In this way, a circulating fluidization is obtained, further stable work of the system is possible, at velocity exceeding the velocity of pneumatic transportation. Apart from the stream of fluidized gas, other important factors determining the particular state of the fluidized bed are also the gas and inert material properties and the mass of inert material in the system.

An important element of the coal combustion is fragmentation, and in CFB conditions – also fuel erosion which has been described in papers: (Arena et al., 1990; Chirone & Massimilla, 1989; Feng & Bhatia, 2000; Gajewski, 1996-1998; Gajewski & Kijo-Kleczkowska, 2006; Pis et al., 1991; Ray & Jiang, 1987; Stubington & Linjewile, 1989).

The essential part here plays a mutual mechanical influence of the particles, which is determined by the dynamics of the fluidized bed. In a fluidized bed, the breakdown of coal particles into smaller elements is caused mostly by:

- thermal shock,
- evolution of coal particles structure,
- combustion of bridges connecting particular fragments of fuel particles,
- mechanical influence of particles.

The breakdown following the first contact of coal with the material of the fluidized bed is a result of a thermal shock and the gradient of temperature in the particle which is connected with it. It also leads to the development of mechanical tensions that make the fuel blast. The primary fragmentation is connected with the increase of pressure in the complicated nets of the pores inside the coal during its devolatilization. The secondary fragmentation is a result of the combustion of bridges connecting different elements of coal particles of an irregular shape. They develop as a consequence of fuel bursting or they are natural elements connected with morphology of coal and with the structure of deposit, from which it originates.

As fuel is covered by a stream of fine-grained inert material during the process there develops erosion of fuel, which influences crucially the course of the combustion process. It leads to tearing out of the ash layer from the fuel surface, resulting in the improvement of conditions of oxygen diffusion to the reaction surface. It also creates favorable conditions for a decrease of fuel mass, contributing to intensification of the combustion process.

Unfavorable for Poland fuel balance causes an excessive charge of environment connected with CO₂, NO_x, SO₂ and dust emissions, and also with the increase of areas necessary to store the growing solid waste. The coal mining, forced to deliver to the power industry better and better fuel, has to use better coal enrichment. This causes the continuous increase of waste in a form of after-flotation mules. The best method of utilization of the mules is their combustion in the form of suspensions and their co-combustion with biomass (Kijo-Kleczkowska et al., 2008; Kijo-Kleczkowska, 2008-2010, 2009, 2010a, 2010b, 2011; Kijo-Kleczkowska & Otwinowski, 2011) carried out, first of all, in boilers with fluidized beds. Modern research on coal–water fuel combustion deals mainly with the advances of combustion technology of low emission NO_x fuels. Development of technology of biomass utilization for power industry brings a number of future benefits, that can be affected by: the biomass availability, the possibility of agricultural utilization of degraded and reclaimed areas, the creation of new work places, the support of local development, the present and forecast coal prices, or a possibility to finance the investment. Although the use of biomass as fuel is profitable, it creates, however, certain problems. They result from physical and chemical properties of biomass: little density, low fuel value and a wide moistness section. However, biomass is one of the most promising sources of renewable energy in Poland, and its co-combustion with coal has been recently successfully applied, in our country and worldwide. At present, co-combustion of biomass with coal-fuel is carried out on industrial scale in a number of Polish power plants.

2. The research setup and measurement methodology

The research has been carried out using an automated combustion chamber that was built into the system, making possible the circulation of fluidized bed material in the furnace contour, which is shown in Fig. 2-4 (Kijo-Kleczkowska, 2008-2010).

The main elements of the system are: a fluidized column, a cyclone, a system of material return and a gas heater.

The investigative part of the stand has been made of heat-proof steel. In order to eliminate the results of its extension during its work in a high temperature, it has been placed on three regulating elements. The fluidized column is 780 mm high and its rectangular diameter is 75×35 mm. At the bottom part of the combustion chamber there is a no-pouring ceramic grate and an air box. At 1/3 of the height of the front column wall there has been placed a flat quartz visual pane, which enables a precise observation of the fuel combustion. At the level of the visual pane a rail made of heat resistant steel has been installed so that the samples of fuel could be put on it. The fuel is introduced to the combustion column at the angle of 40°, in order to eliminate entirely the blowing away of the inert material and its gravitational pouring. The specially well-fitted bed with the installed system of measurement of fuel temperature changes (made of thermocouples Pt-PtRh) is at the same time the element that does not allow the sample to enter the fluidized column.

In the upper part of the combustion chamber there is an exit to the cyclone, where a quartz tube of internal diameter 25 mm, makes possible the simultaneous observation of the return system in the contour of the furnace. The exit of fumes to the chimney is held by means of the “nurnic”. At the bottom part of the return system has been placed a siphon with a ceramic fire grate and a box aerial. The siphon is made of heat-proof steel. In order to improve the flow of the inert material back to the fluidized column the siphon has been divided into two chambers by means of the internal wall. The outlet that lets the inert material in to the combustion chamber is 25×28 mm and is made at 1/4 of the height from the fire grate, which affects very much

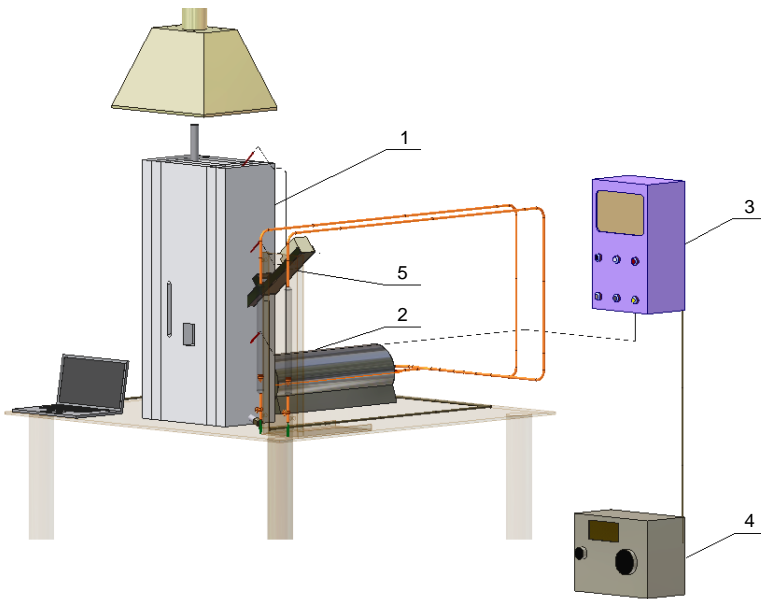

Fig. 2. The research stand for fuel combustion in a stream of air and in a circulating fluidized bed and the process visualization; 1 – fluidized column, 2 – gas heater, 3 – control box, 4 – power driver, 5 – fuel introduction system

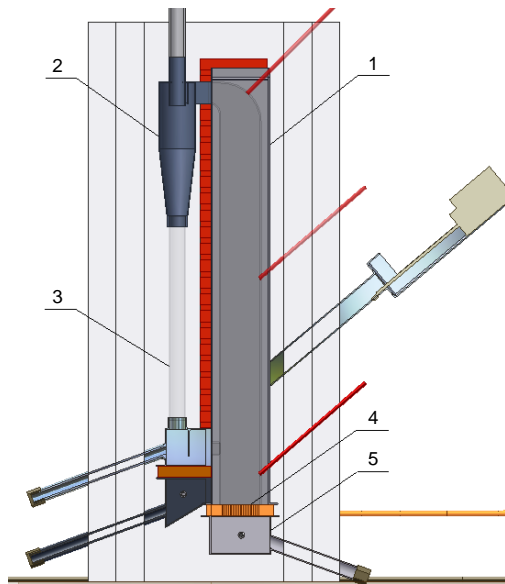

Fig. 3. The section of the research stand for fuel combustion in a stream of air and in a circulating fluidized bed and the process visualization; 1 – fluidized column, 2 – cyclone, 3 – return system, 4 – no-pouring fire grate, 5 – air box

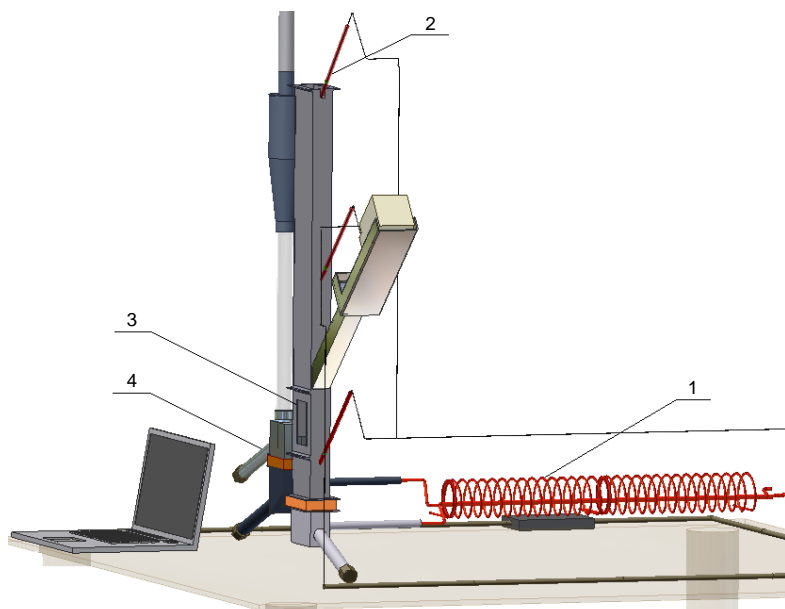

Fig. 4. The research stand for fuel combustion in a stream of air and in a circulating fluidized bed (without insulation) ; 1 – gas heater, 2 – thermocouple Ni-CrNi, 3 – visualization pane, 4 – inert material pouring out place of fluidized bed material

efficiency of the circulation course. The fire grate and the air box are divided into two sections, with respect to the particular parts of the siphon. In order to eliminate the heat loss, a heating element of 1,2 kW has been installed under the air boxes. At the front and at the back, along the whole combustion column (with the exception of the observation pane) hard, pressed fibril plates with ceramic elements have been installed, inside which there is a system of heating elements of 8 kW, indispensable to keep the required temperatures in the fluidized chamber.

All construction: the combustion chamber, the cyclone and the return system have been insulated with mats made of pressed aluminium oxide and protected with metal sheets made of stainless steel. In order to enable the removal and inspection of quantity of the inert material the special pour out –tubes have been installed.

The gas has been delivered to the air chambers by two pipe coils, which are 3,5 m and 10 and 8 mm in diameters and made of heat-proof steel. On the outside of the pipe coils a ceramic element with a sunken, cantal-wire has been installed making a gas heater of 4,4 kW. The stream volume of the gas flowing to the fluidized column has been controlled by means of rotameters installed next to the research stand. The air flow velocity in all described research stands has been determined as a quotient of gas stream volume to the surface area of the transverse section of the combustion chamber.

In order to keep the temperature in the gas heater and in the combustion chamber (at three different points of the height) thermo-elements NiCr-Ni, cooperating with regulators of temperature have been installed.

The entire time of fuel combustion has been marked on the basis of fuel temperature changes. The slurry is a mixture of pulverized coal, coal-mule, biomass and water, in different proportions.

The properties of fuel used in the research are presented in Table 1.

TABLE 1

Proximate analysis of the sample

Type of fuel	Moisture content	Volatiles content	Ash content	Calorific value	Carbon content	Hydrogen content	Nitrogen content	Oxygen content	Total Sulphur content
	W ^a	V ^a	A ^a	Q _i ^a	C _t ^a	H _t ^a	N ^a	O _d ^a	S _t ^a
	%	%	%	kJ/kg	%	%	%	%	%
coal-mule	4,51	20,45	39,43	15024	40,12	2,82	0,54	12,11	0,72
hard coal	10,08	28,91	11,07	23488	59,89	3,62	1,17	12,89	1,71
cereal bruised grain	8,45	70,53	4,55	15825	40,90	6,07	2,73	37,30	0,18

3. Experimental research results

Conditions of a circulating fluidized bed essentially affect the course of fuel and coal-water suspension combustion process. In the paper there has been carried out the identification of moistness influence, of coal-mule and biomass content of the fuel and of the effect of air flow velocity on the combustion time of coal-water fuels in the circulating fluidized bed. In the table below some examples of experiment results, carried out with the use of the rotal-uniformal schedule of the research have been presented (Table 2) (Polański, 1984).

In the research the following parameters have been accepted:

x_1 – coal-mule content of fuel*, %,

x_2 – biomass content of fuel**, %,

x_3 – moisture content, %,

x_4 – air flow velocity, m/s,

* – mixture of pulverized coal and coal-mule,

** – mixture of pulverized coal, coal-mule and biomass.

Results of the research have been approximated with a polynomial function of the second degree with interactions of the first line. After introduction of the calculated coefficients of approximated polynomial the following results have been received:

$$\begin{aligned} \bar{z} = & 239 - 27,17 \cdot \hat{x}_1 - 26,00 \cdot \hat{x}_2 - 8,08 \cdot \hat{x}_3 - 5,67 \cdot \hat{x}_4 - 0,52 \cdot \hat{x}_1^2 + 6,48 \cdot \hat{x}_2^2 \\ & - 10,78 \cdot \hat{x}_3^2 - 7,15 \cdot \hat{x}_4^2 + 12,00 \cdot \hat{x}_1 \cdot \hat{x}_2 + 2,38 \cdot \hat{x}_1 \cdot \hat{x}_3 + 13,63 \cdot \hat{x}_1 \cdot \hat{x}_4 \\ & + 9,38 \cdot \hat{x}_2 \cdot \hat{x}_3 + 7,38 \cdot \hat{x}_2 \cdot \hat{x}_4 + 0,75 \cdot \hat{x}_3 \cdot \hat{x}_4 \end{aligned} \quad (1)$$

\bar{z} – approximate value of exit – magnitude counted from the function of the research object for
 u – measurement,

$$\hat{x}_k = \frac{2 \cdot \alpha_{rot} \cdot (x_k - \bar{x}_k)}{x_{kmax} - x_{kmin}} \quad (2)$$

where: $\alpha_{rot} = 2$, $\bar{x}_1 = 50$, $\bar{x}_2 = 50$, $\bar{x}_3 = 35$, $\bar{x}_4 = 1,83$.

The research program of coal-water fuels ($i = 4$, $\alpha_{rot} = 2$, $n_0 = 7$)

u	x_k			
	x_1	x_2	x_3	x_4
1	25	25	27,5	1,62
2	75	25	27,5	1,62
3	25	75	27,5	1,62
4	75	75	27,5	1,62
5	25	25	42,5	1,62
6	75	25	42,5	1,62
7	25	75	42,5	1,62
8	75	75	42,5	1,62
9	25	25	27,5	2,03
10	75	25	27,5	2,03
11	25	75	27,5	2,03
12	75	75	27,5	2,03
13	25	25	42,5	2,03
14	75	25	42,5	2,03
15	25	75	42,5	2,03
16	75	75	42,5	2,03
17	0	50	35	1,83
18	100	50	35	1,83
19	50	0	35	1,83
20	50	100	35	1,83
21	50	50	20	1,83
22	50	50	50	1,83
23	50	50	35	1,42
24	50	50	35	2,23
25	50	50	35	1,83
26	50	50	35	1,83
27	50	50	35	1,83
28	50	50	35	1,83
29	50	50	35	1,83
30	50	50	35	1,83
31	50	50	35	1,83

Figures 5-10 show examples of the influence of different process parameters on the course of combustion of coal-water fuel, with the use of quartz sand of granulation below $160 \mu\text{m}$ as the fluidized bed material. The volume of the inert material flow changes from 0,8 to $5,2 \text{ kg/m}^2\text{s}$ (Bis, 1991), depending on the flowing air velocity.

In the accepted process conditions it has been found that:

- considerable influence of air velocity on the combustion time of suspension that contains smaller amount of biomass (Fig. 5),
- shortening of the combustion time with a parallel increase of fuel moistness of fuel containing smaller amount of biomass (Fig. 6),

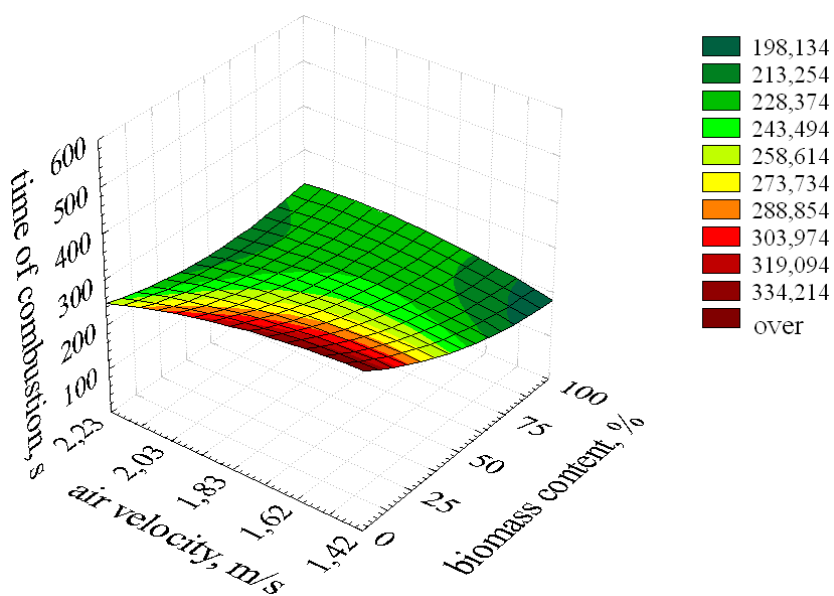

Fig. 5. The influence of air flow velocity and the biomass content in suspension on the fuel combustion time in a fluidized bed; $T = 850^{\circ}\text{C}$

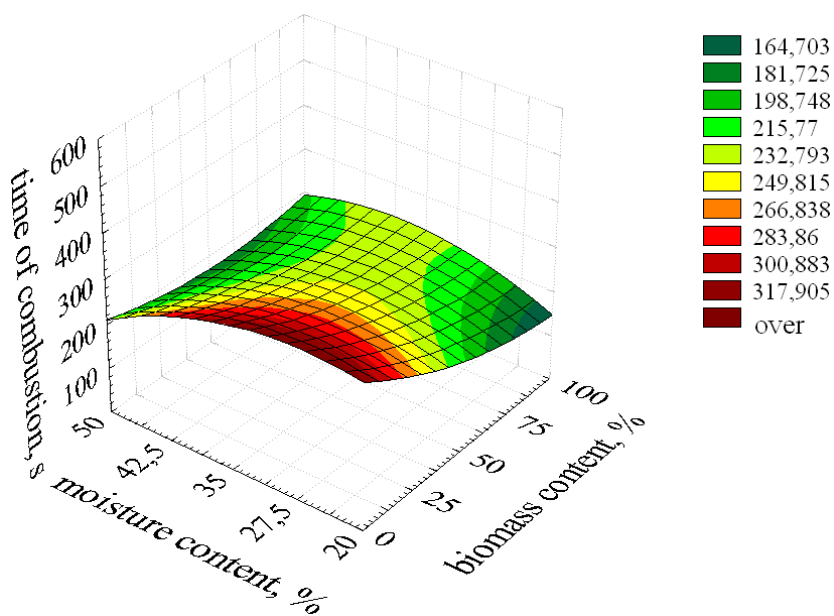

Fig. 6. The influence of suspension moistness and biomass content in suspension on the fuel combustion time in a fluidized bed; $T = 850^{\circ}\text{C}$

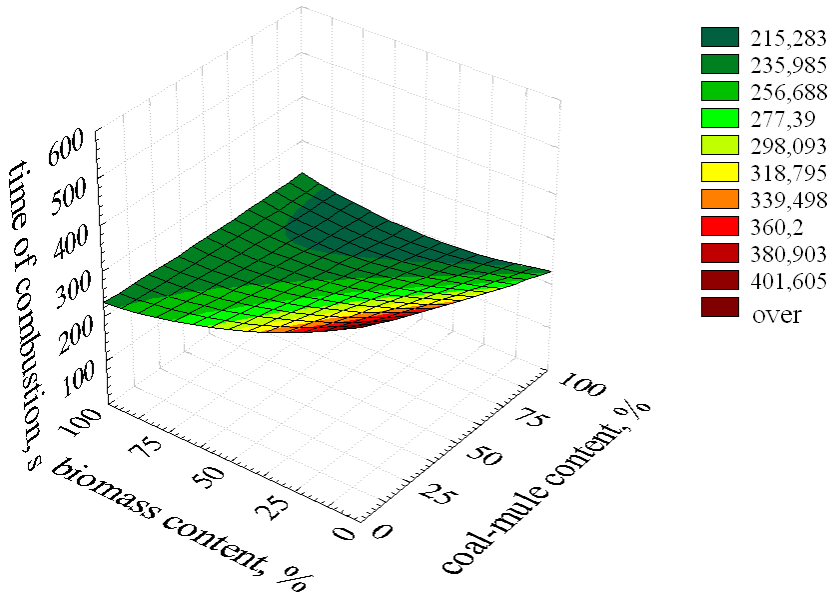

Fig. 7. The influence biomass and coal-mule content in suspension on the fuel combustion time in a fluidized bed; T = 850°C

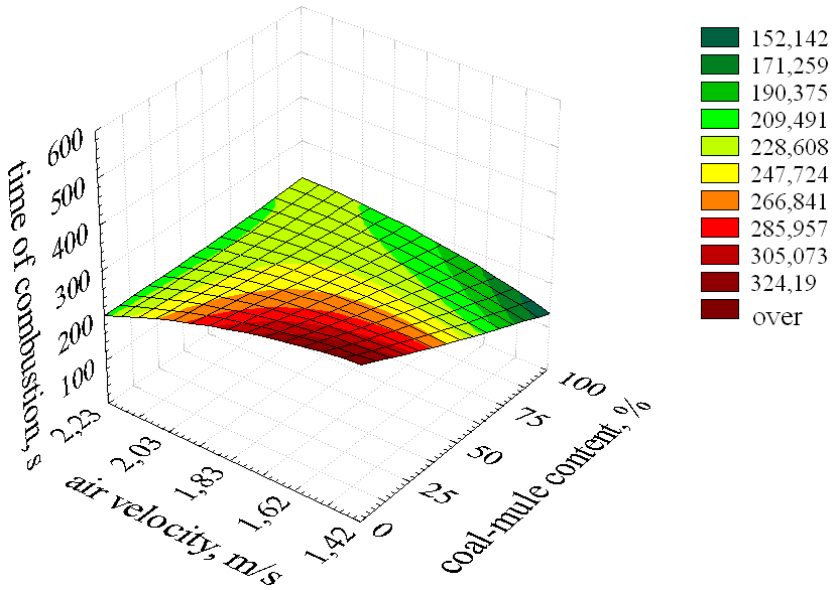

Fig. 8. The influence of air flow velocity and coal-mule content of suspension on the fuel combustion time in a fluidized bed; T = 850°C

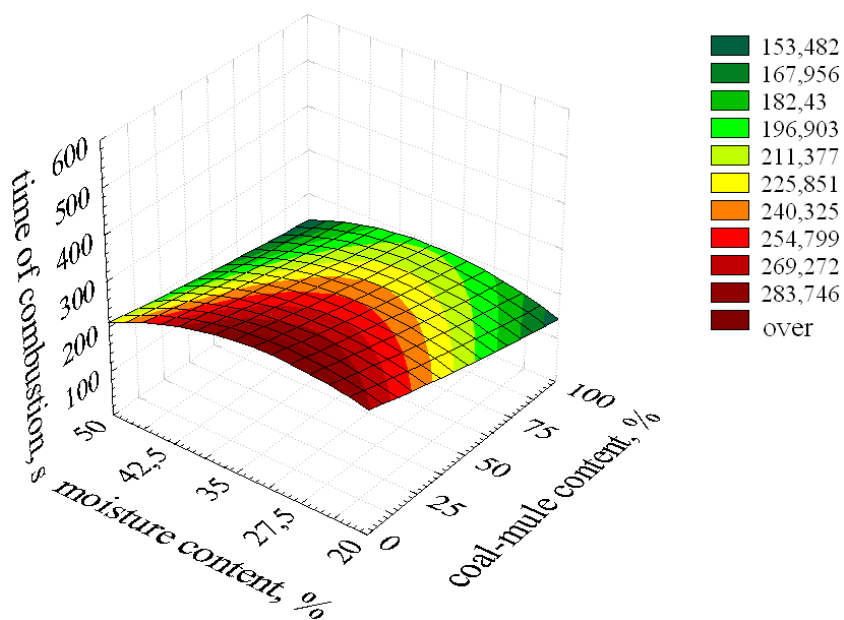

Fig. 9. The influence of suspension moistness and coal-mule content in suspension on the fuel combustion time in a fluidized bed; $T = 850^{\circ}\text{C}$

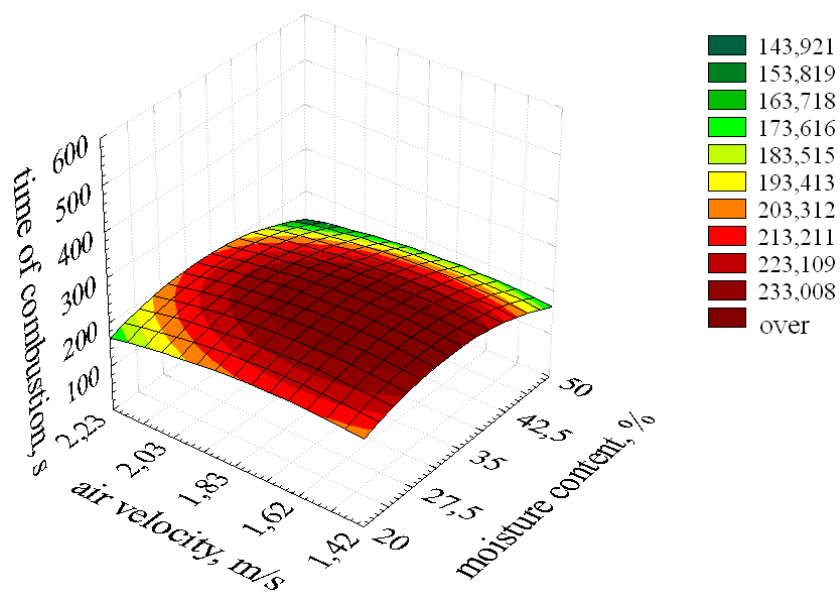

Fig. 10. The influence of suspension moistness and air flow velocity on the fuel combustion time in a fluidized bed; $T = 850^{\circ}\text{C}$

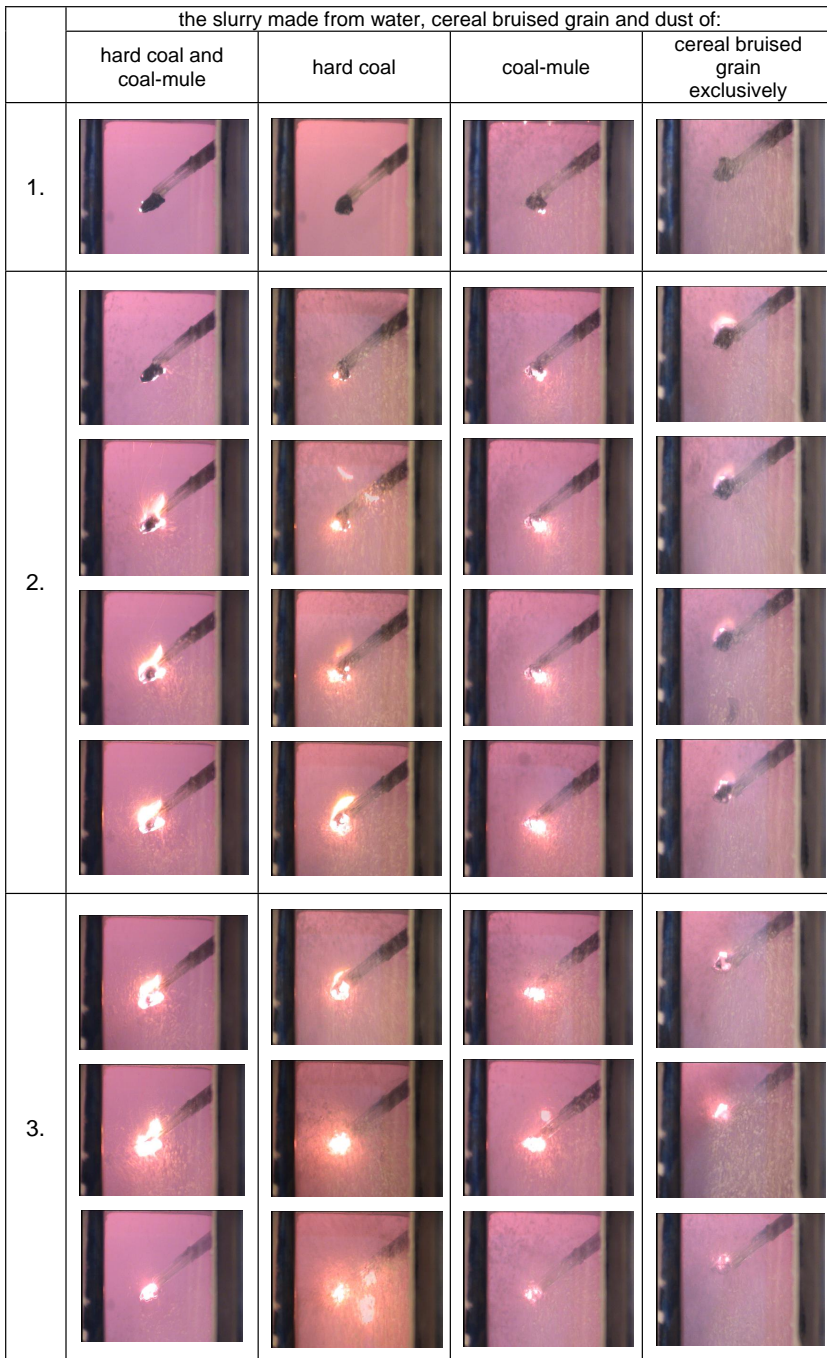

Fig. 11. Example of a course of coal-water fuel combustion process in the fluidized bed;
 1 – heating and vaporization of moisture, 2 – devolatilization, ignition and combustion of volatiles matter,
 3 – combustion of char-suspension; $W = 35\%$; $T = 850^{\circ}\text{C}$ (Kijo-Kleczkowska, 2008-2010)

- significant shortening of the combustion time of suspension with a parallel increase of a biomass content but with a smaller coal-mule content (Fig. 7),
- big influence of air flow velocity on the combustion time of fuels possessing less coal-mule (Fig. 8),
- considerable shortening of the combustion time of fuel characterized by a smaller coal-mule content with parallel higher moistness (Fig. 9),
- shortening of the combustion time of suspension with a parallel increase of coal-mule content, at smaller fuel moistness, lower air flow velocity and a biomass content (Fig. 7-9),
- considerable shortening of the process time with a parallel increase of air flow velocity, at smaller moistness of fuel (Fig. 10).

It should be stressed that a clear tendency to shorten the process time with a parallel increase of air flow velocity to suspension during combustion in the fluidized bed, is caused by a growing process of fuel erosion. It is accompanied by intensification of heating process of suspension in the first phase of the process and the rise of temperature of fuel ignition, resulting, first of all, from the size reduction of the fuel sample during the combustion process (Kijo-Kleczkowska, 2008-2010).

According to (Bis, 1991) if the concentration of bed material increases (G_s) the concentration of raised inert material particles also grows. This increases a probability of mutual collisions of small grains, shifting to the surface direction of fuel with grains, which after collision with the surface of fuel move in the opposite direction. There is a terminal value (G_s), exceeding of which makes the collisions disappear, and in this place a motionless concentration of grains of the inert material appear and they almost completely close the fuel surface. High value (G_s) of the stream intensity of bed material can cause a situation, in which the concentration of grains of bed material surrounding the fuel practically covers their surface, leading even to disappearance of marks showing that fuel has been covered (Gajewski, 1996-1998). When fuel is covered by a diluted stream of particles of the fluidized bed material, the single particles of the inert material colliding with the surface of fuel exchange heat in two ways: by direct contact of the fuel surface with small particles and by a thermal contact that occurs when the particles stay in the fluidized bed surrounding fuel (Gajewski, 1996-1998). In case of intensive erosion of fuel suspension which is a result of collisions with the fluidized bed material there occurs a visible tearing out of particles from the surface of suspension and also the breakdown of fuel into smaller fragments. This occurrence can be observed in photos (Fig. 11).

4. Conclusions

1. Addition of biomass dust to coal-fuel intensifies the course of combustion process, by quicker heating of fuel and lower temperature of ignition.
2. The specificity of combustion of coal-water suspensions in the fluidized bed changes the mechanism and kinetics of the process.
3. The moistness increase of coal-water suspension causes the intensification of fuel surface covering by the fluidized bed material, and grows with the lowering of fluidization velocity and increasing of the inert material quantity, that circulate in the fluidized column.
4. A considerable shortening of the process time takes place parallel with the increase of air flow velocity, in the range of smaller coal-mule and moisture content of the suspension, as well as with the high biomass content of the fuel.

References

- Arena U., Cammarota A., Massimilla L., Siciliano L., Basu P., 1990. *Carbon attrition during the combustion of a char in a circulating fluidized bed*. Combustion Science and Technology 73, pp. 383-394.
- Basu P., Fraser S.A., 1991. *Circulating Fluidized Bed Boilers. Design and Operations*, Butterworth-Heinemann (USA).
- Bis Z., 1991. *Aerodynamics of the circulating fluidized bed*. Series Monographs No 21. Publishers of Technical University of Czestochowa.
- Chirone R., Massimilla L., 1989. *The application of Weibull theory to primary fragmentation of a coal during devolatilization*. Powder Technology 57, pp. 197-212.
- Feng B., Bhatia S.K., 2000. *Percolative fragmentation of char particles during gasification*. Energy and Fuels 14, pp. 297-307.
- Gajewski W., 1996-1998. *The research of combustion mechanism of coal particles in the circulating fluidized bed*. Report of investigative project. No 8T10 044 10.
- Gajewski W., 2005-2008. *Analysis of processes of coal-water suspensions combustion in the fluidized bed*. Report of investigative project. No 3 T10B 084 28.
- Gajewski W., Kijo-Kleczkowska A., 2004. *The kinetics of periodic combustion of coal*. Powder Handling & Processing 16, 2 pp. 126-131.
- Gajewski W., Kijo-Kleczkowska A., 2006. *Solid fuels particles fragmentation during the periodic combustion*. Archivum Combustionis 26 nr 1-2, pp. 3-81.
- Gajewski W., Kijo-Kleczkowska A., 2007. *Co-combustion of coal and biomass in the fluidized bed*. Archives of Thermodynamics 28, no. 4, pp. 63-77.
- Gajewski W., Kijo-Kleczkowska A., Leszczyński J., 2009. *Analysis of cyclic combustion of solid fuels*. Fuel 88, pp. 221-234.
- Grace J.R., Knowlton T.M., Avidan A.A., 1997. *Circulating Fluidized Beds*. Chapman & Hall, London.
- Kijo-Kleczkowska A., 2008-2010. *Mechanism of coal-water fuels co-combustion with biomass*. Report of investigative project. No N N513 309935.
- Kijo-Kleczkowska A., 2009. *Analysis Combustion Process of Coal-Water Fuel*. Archives of Mining Sciences, 54, 1, pp. 119-133.
- Kijo-Kleczkowska A., 2010a. *Research on destruction mechanism of drops and evolution of coal-water suspension in combustion process*. Archives of Mining Sciences 55, nr 4, pp. 923-946.
- Kijo-Kleczkowska A., 2010b. *Analysis of the Co-Combustion Process of Coal-Water Slurries and Biomass*. Archives of Mining Sciences 55, nr 3, pp. 487-500.
- Kijo-Kleczkowska A., 2011a. *Combustion of coal-water suspensions*. Fuel 90, pp. 865-877.
- Kijo-Kleczkowska A., 2011b. *Analysis of cyclic combustion of coal-water suspension*. Archives of Thermodynamics 32, pp. 45-75.
- Kijo-Kleczkowska A., Gajewski W., Kosowska-Golachowska M., 2008. *Mechanism and kinetics of the co-combustion process of coal-water slurries and biomass*. Proceedings of ECOS, pp. 859-866, Cracow - Gliwice, Poland, June 24-27, 2008.
- Kijo-Kleczkowska A., Otwinowski H., 2011. *Analysis of the coal and biomass co-combustion in the water-slurries form*. 38th International Conference of SSCHE, May 23-27, Tatranske Matliare, Slovakia, p. 176.
- Pis J.J., Fuertes A.B., Artos V., Suarez A., Rubiera F., 1991. *Attrition of coal ash particles in a fluidized bed*. Powder Technology 66, pp. 41-46.
- Polański Z., 1984. *Planning of experiences in technics*. PWN, Warsaw.
- Ray Y.-Ch., Jiang T.-S., 1987. *Particle attrition phenomena in a fluidized bed*. Powder Technology 49, pp. 193-206.
- Stubington J.F., Linjewile T.M., 1989. *The effects of fragmentation on devolatilization of large coal particles*. Fuel 68, pp. 155-160.

Received: 22 July 2011