

Krzysztof Dominiczak<sup>a,b\*</sup>, Mariusz Banaszekiewicz<sup>a,b</sup>

## A verification approach to thermoelastic steam turbine rotor analysis during transient operation

<sup>a</sup> *GE Power sp. z o.o., Stoczniowa 2, 82-300 Elbląg, Poland*

<sup>b</sup> *The Szewalski Institute of Fluid-Flow Machinery of the Polish Academy of Sciences, 80-231 Gdańsk, Fiszerka 14, Poland*

### Abstract

This paper presents a verification approach to thermoelastic steam turbine rotor analysis. Neither temperature nor stresses are measured on the rotor surface in utility power plants. Therefore analysis of the steam turbine rotor can be verified only based on absolute and differential thermal expansion measurements in vicinity of the steam turbine. Absolute and differential expansion measurements and steam turbine fixed points arrangement allow to calculate thermal growth of the steam turbine rotor during transients. Thermal growth of the rotor can be a baseline for the calculation using a numerical model.

**Keywords:** Steam turbine; Thermal stress; Thermal growth; Differential expansion

## 1 Introduction

Neither temperature nor stresses are measured on the steam turbine rotor surface in professional power plants. In order to verify calculation model of steam turbine rotor, indirect method needs to be used [1–3]. This paper presents a method for steam turbine rotor model verification. The method is based on steam turbine rotor thermal growth, which can be assessed using absolute and differential expansion measurement as well as trust bearing float. Steam turbine fixed point arrangement needs also be taken into account for this method.

---

\*Corresponding Author. Email address: krzysztof.dominiczak@ge.com

The method is presented using the example of a 18K390 high pressure steam turbine rotor (Fig. 1). The 18K390 condensing turbine has a reaction-type blading reheated in the turbine with seven feedwater preheaters, designed to drive a synchronous generator. The nominal live steam parameters are 18.2 MPa/557 °C, whereas nominal reheat steam parameters are 4.2 MPa/568 °C.

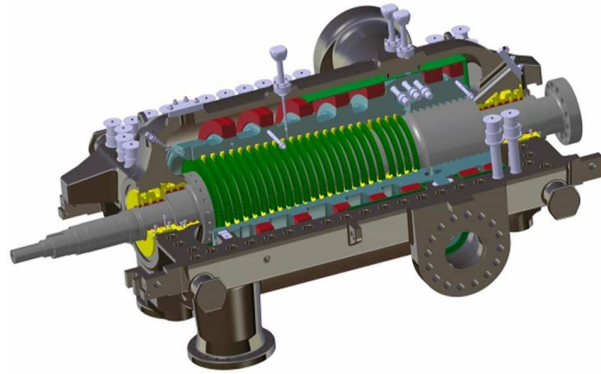

Figure 1: High pressure section of 18K390 steam turbine.

The high pressure (HP) rotor is a reaction type blading drum design rotor with 24 blade rows. The high pressure rotor is welded from two forgings. In the inlet hot region, a high-alloy steel is used, whereas in the exhaust cold region, a low-alloy steel is applied. The high pressure rotor is 5625 mm long and the assembled blade rows weigh approximately 10.5 tons. The rotor diameter at the steam inlet is 653 mm, whereas at the steam path exhaust it is 686 mm.

For the purpose of the method, the following measurements are required: high pressure differential expansion, high pressure absolute expansion, intermediate pressure absolute expansion and thrust bearing float.

## 2 Thermal expansion measurement system

High pressure differential expansion is a difference between the high pressure rotor thermal growth and the high pressure outer casing thermal growth. This difference is mainly caused by two factors. The first one is different thermal expansion coefficient of casing and rotor materials. The second one is a difference in heat exchange conditions with steam for these two steam turbine components. The high pressure differential expansion sensor of 18K390 steam turbine is assembled to the high pressure glands (Fig. 2). Strong magnet, which is located at the tip of the sensor, allows for contactless track of the measurement disc on the

rotor surface. The magnet is attached to the lever. To the opposite side of the lever, conical cores of eddy current system are attached. The eddy current system includes two inductive elements connected to coaxial cables with the transmitter. Inductors with cables form resonant circuits. Changes of the core position in the induction elements generate voltage, which represents relative movement of the steam turbine rotor.

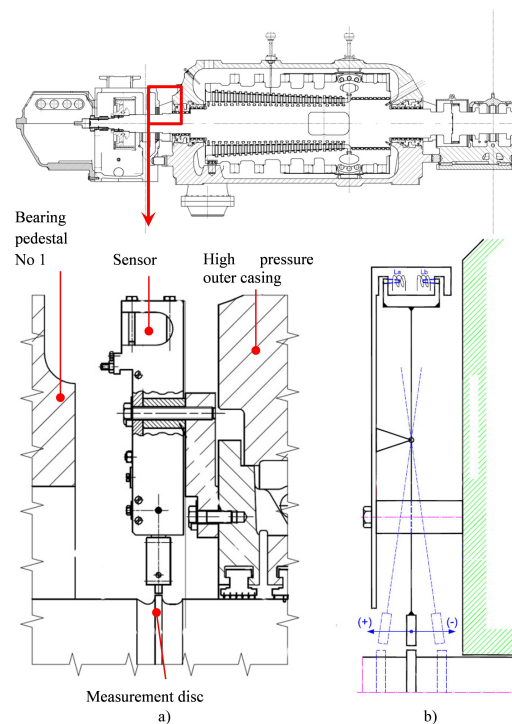

Figure 2: High pressure differential expansion sensor: measurement (a) and principle of operation (b).

High and intermediate pressure absolute expansions are the thermal growth of the casing line. The high pressure absolute expansion sensor is attached to the bearing pedestal no. 1 (Fig. 3), which is located in the vicinity of steam turbine high pressure exhaust. Bearing pedestal no. 1 is fixed to the foundation. High pressure outer casing paws are sliding on this bearing pedestal. These paws constitute resistance surfaces for the movable part of the high pressure absolute expansion sensor. The intermediate pressure absolute expansion sensor is attached to bearing pedestal no. 2 (Fig. 3), which is located between high and intermediate

pressure part of the turbine. Bearing pedestal no. 2 is pushed by the intermediate pressure outer casing. Next bearing pedestal no. 2 pushes the high pressure outer casing. Movable part of the intermediate pressure absolute expansion sensor rests on the resistance element fixed to the foundation. The operation principles of absolute expansion sensor measurement are similar to differential expansion measurement.

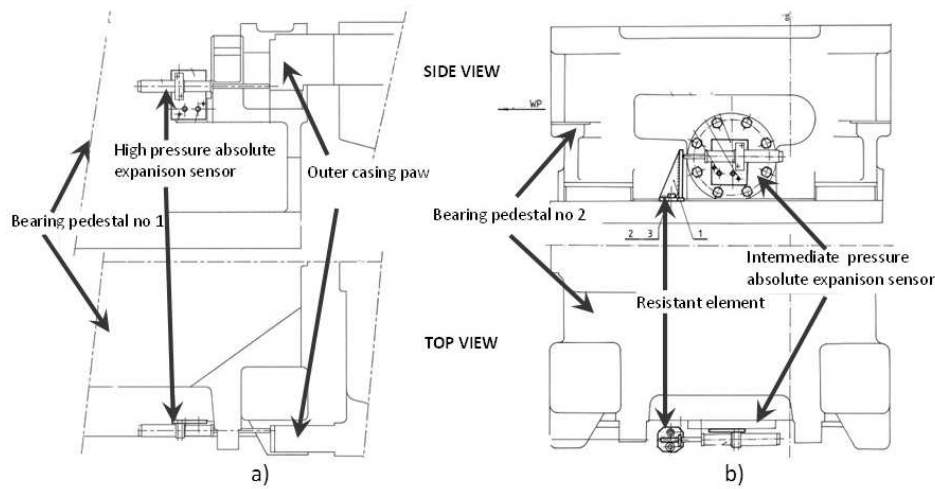

Figure 3: Absolute expansion sensor: high pressure (a) and intermediate pressure (b).

For the considered in this article steam turbine, there are two absolute fixed points. The first point is located in low pressure part steam inlet axis. The second one, which is relevant for the presented paper investigation, is located in bearing pedestal no. 3 at intermediate pressure turbine part exhaust. This pedestal, intermediate pressure outer casing, bearing pedestal no. 2 and high pressure outer casing are tight together. Due to thermal growth, pedestals and casings expand in one direction. Rotor relative fix point is located in thrust bearing, which is pushed by intermediate pressure outer casing. The high pressure rotor expands in the same direction as the high pressure outer casing, whereas intermediate rotor expands in opposite direction in comparison with intermediate pressure outer casing. Figure 4 shows fix points and expansion measurement arrangement for 18K390 turbine. In order to calculate high pressure rotor growth, the following formula should be used [3]:

$$\Delta L = AE_{HP} - AE_{IP} + DE_{HP} + TF, \quad (1)$$

where:  $\Delta L$  – high pressure rotor growth,  $AE_{HP}$  – high pressure absolute expansion,  $AE_{IP}$  – intermediate pressure absolute expansion,  $DE_{HP}$  – high pressure differential expansion, and  $TF$  – thrust bearing float.

Equation (1) is used for verification of rotor calculation in transient states. Rotor growth calculated based on experimental data can be compared with results obtained from numerical model.

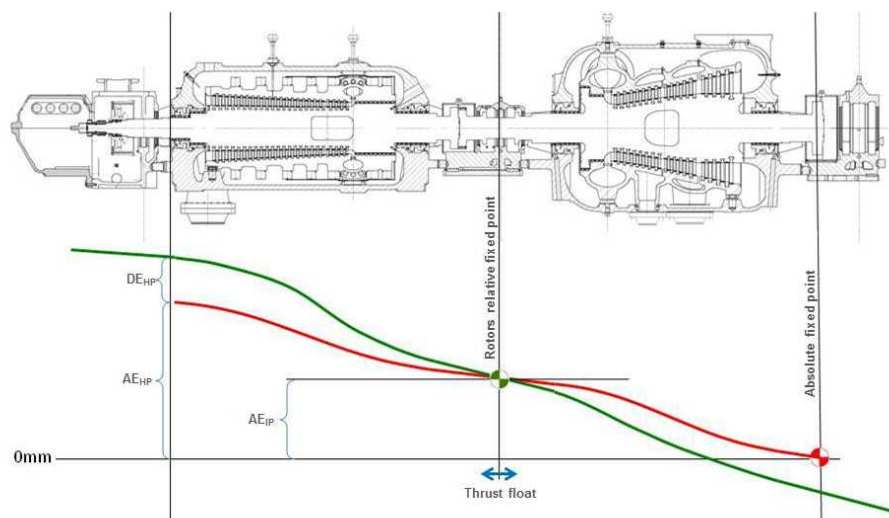

Figure 4: Fix points and expansion measurement arrangement of 18K390 steam turbine.

### 3 Rotor model for transient state calculation

In order to perform numerical analysis of steam turbine rotor in transient states, boundary conditions, i.e., transient steam parameters distributions inside turbine as well as heat transfer characteristics have to be known. Steam parameters are derived based on thermodynamic turbine model, whereas heat transfer model is used for derivation of heat transfer coefficients.

The thermodynamic model derives actual steam flow through the turbine as well as steam parameters inside the turbine based on actual steam parameters before control valves, actual turbine speed, actual turbine load and turbine backpressure (in considered case backpressure is equal to pressure in cold reheat). Thermodynamic model performance was checked based on measurements installed in the vicinity of high pressure part. Steam flow through the turbine was veri-

fied based on steam flow measurement installed on live steam pipeline. As far as steam parameters inside the high pressure turbine are concerned, they were verified in two points: at the inlet to high pressure steam path and at the steam path exhaust. There are temperature and pressure measurements at the steam path inlet. In case of steam path exhaust, there is temperature measurement located in high pressure turbine outer casing. Pressure at the high pressure exhaust is measured at pipeline before safety valves at the cold reheat pipelines.

Steam flow through the turbine for near design conditions has been calculated based on Stodola's law [4]. For lower flows, for which velocity triangles have not been established yet, calculated flow is corrected by experimental coefficient. Figure 5 shows calculated flow through high pressure part for turbine cold startup in comparison with experimental data. Based on heat balance diagram for different turbine states, high pressure steam path characteristic was recognized. This characteristic was used in thermodynamic model of high pressure turbine part. However, adiabatic model has been assumed for modeling purposes. Possibility of performing sequence calculation is more beneficial than better accuracy of thermodynamic model, especially for colder turbine states [2,3]. Figure 6 shows a comparison of steam temperature after high pressure turbine control valve calculated based on the thermodynamic model with measured values during turbine warm startup I. Figure 7 shows a comparison of temperature at the high pressure exhaust calculated based on thermodynamic model with real data for the same turbine warm startup I.

Next step of high pressure rotor transients modeling is heat exchange model. High pressure rotor was divided into regions (Fig. 8) for which heat exchange conditions were described by proper Nusselt number correlations [5]. As an example Fig. 9 shows the heat transfer coefficient at rotor surface after first stationary radial-axial stage.

Finite element (FE) modeling of steam turbine rotor consists of:

- thermal analysis in which transient temperature field in turbine rotor is calculated based on heat transfer between steam flowing through turbine and turbine components,
- structural analysis in which stress distribution for the considered transient event is calculated.

The FE rotor model is shown in Fig. 10. It is axisymmetric model which consist of about 9000 elements and 31 000 nodes. The axisymmetric 8-node bilinear temperature elements were applied for the temperature analyses and the axisymmetric stress elements with 8-node biquadratic displacement were applied for the subsequent thermoelastic analyses.

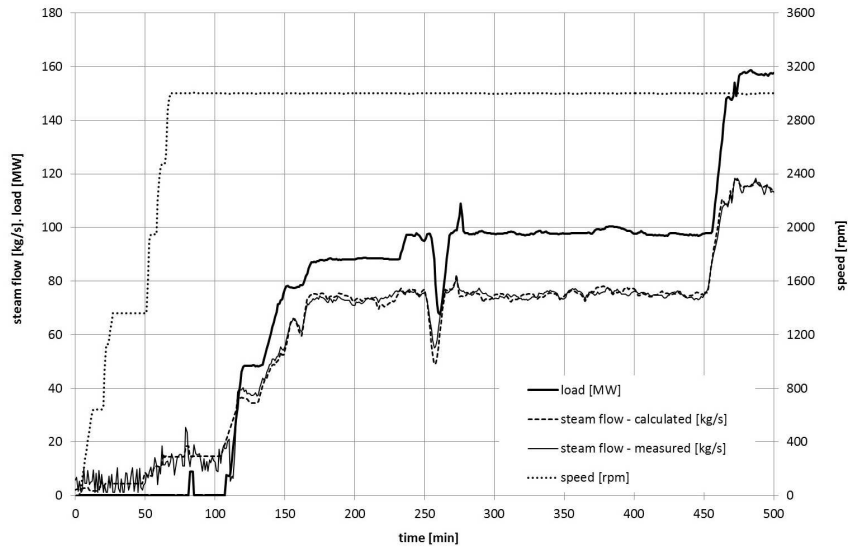

Figure 5: Steam flow through turbine for real cold startup: theory vs. measurement.

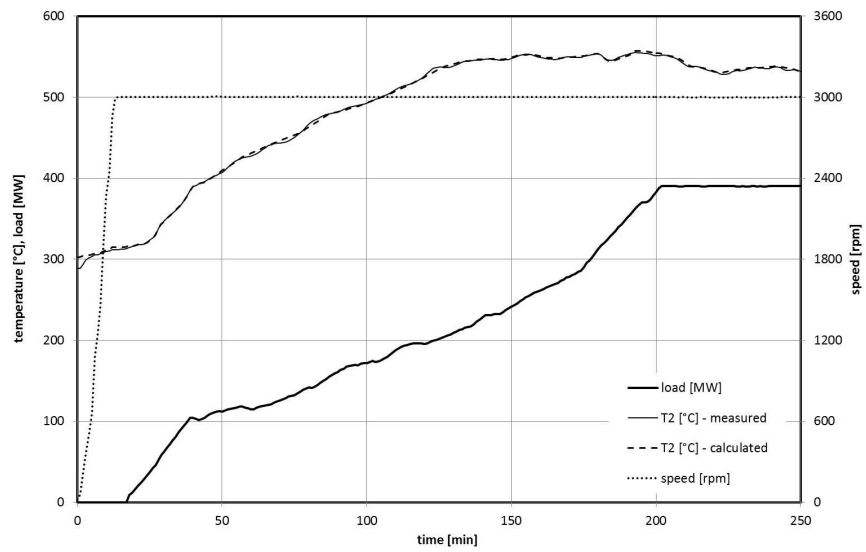

Figure 6: Comparison of calculated steam temperature before high pressure steam path with experimental data for warm startup.

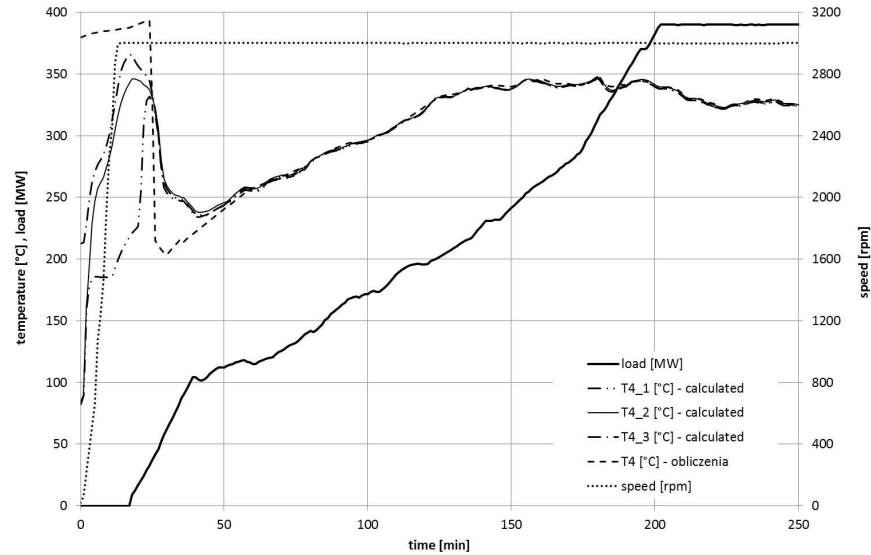

Figure 7: Comparison of calculated steam temperature at high pressure exhaust with experimental data.

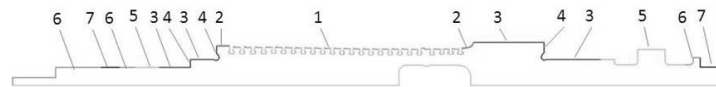

Figure 8: HP rotor division into heat exchange region.

## 4 Verification of calculation model

For the considered turbine there is only one experimental possibility to verify heat exchange model and FE model, i.e., by rotor thermal and mechanical growth. Rotor growth can easily be obtained from FE model, whereas for real data can be calculated based on operational data according to Eq. (1).

Verification was performed for various steam turbine transient operation events, i.e., cold startup, warm startups, hot start up, shut down and load rejection. In all considered cases, the rotor growth was within band defined by the accuracy of measurements used in Eq. (1) and variation of the calculated rotor growth was the same as growth derived from operational data. Therefore, the presented method is suitable for verification of numerical calculation of steam turbine rotors



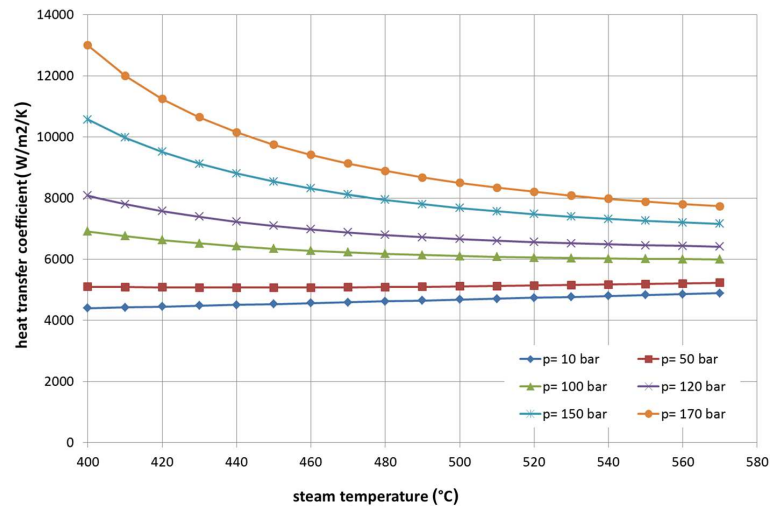

Figure 9: Heat transfer coefficient at rotor surface after first stationary radial-axial stage.

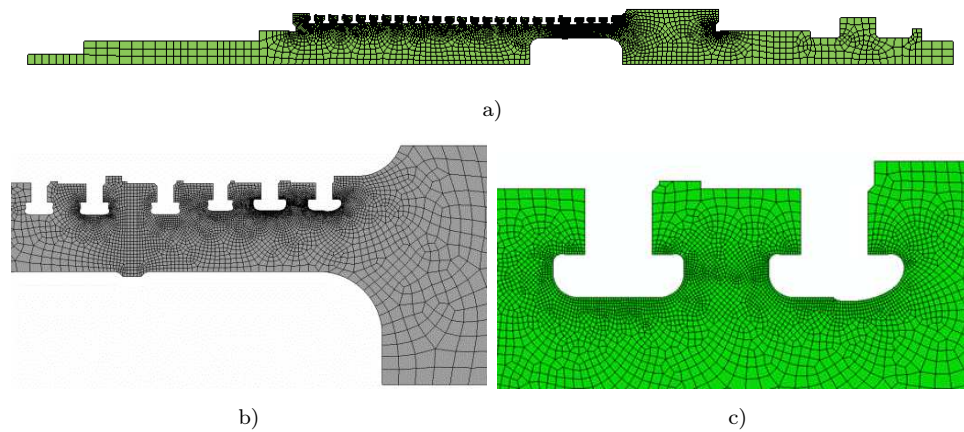

Figure 10: FE model of 18K390 turbine high pressure rotor: a) whole model, b) steam inlet view, c) 1st and 2nd blades grooves.

during transient operation. Figure 11 shows a comparison between rotor growth obtained from numerical calculation and derived from operational data for turbine cold startup.

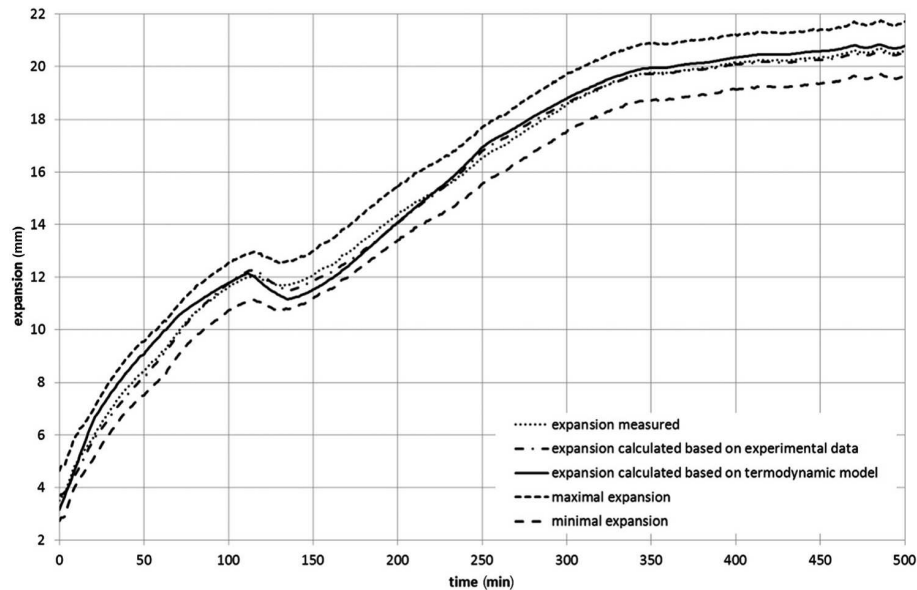

Figure 11: HP rotor axial growth during cold startup; calculated vs. measured.

## 5 Summary

This article presented a verification approach to thermoelastic steam turbine rotor analysis. The verification method is based on absolute and differential thermal expansion measurements in the vicinity of the steam turbine. Absolute and differential expansion measurements and steam turbine fixed points arrangement allow to calculate thermal growth of the steam turbine rotor during transients. Thermal growth of the rotor can be a baseline for the calculation using numerical model. The verification method was validated for various steam turbine transient operation events as startups, shut down and load rejection.

*Received in July 2016*

## References

- [1] Banaszekiewicz M.: *On-line monitoring and control of thermal stresses in steam turbine rotors*. Appl. Therm. Eng. **64**(2016), 763–776.
- [2] Dominiczak K., Rządowski R., Radulski W., Szczepanik R.: *Online prediction of temperature and stress in steam turbine components using neural networks*. J. Eng. Gas Turbines Power **138**(2015), 5, 052606-052606-13, GTP-15-1396.

- [3] Dominiczak K., Rządkowski R., Radulski W., Szczepanik R.: *Neural networks in steam turbine thermal stress limiter*. Wydawnictwo Naukowe Instytutu Technologii Eksploatacji, Warszawa 2015 (in Polish).
- [4] Perycz S.: *Steam and Gas Turbines*. Ossolineum, Wrocław 1992 (in Polish).
- [5] Taler J.: *Solving simple and inverse heat conduction problems*. Ossolineum, Wrocław 1995 (in Polish).