

DEFORMATION NETS FOR CYLINDRICAL AND CONICAL ANAMORPHS

Andrzej ZDZIARSKI

Division of Descriptive Geometry, Technical Drawing and Engineering Graphics, A-6
Cracow University of Technology
Warszawska st. 24, 31-155 Kraków, POLAND
e-mail: a-6@pk.edu.pl

Abstract. The objective of this paper is to present various types of deformation nets (=geometrical matrices) for surface anamorphs. Specifically, the discussion focuses on cylindrical and conical surface anamorphs. Several examples of these deformation nets for particular cases of surfaces, on which the nets are produced, will be shown.

Keywords: anamorphic images (=anamorphs), plane anamorphs, surface (=superficial) and mirror anamorphs

1. Introduction

This publication is a continuation of the discussion on anamorphic images, which was presented in earlier publications ([6], [7], [8]). Deformation nets or geometrical matrices, as this term is occasionally used in international literature, are the most commonly used means to produce anamorphic images. This method has been known by the artists since long ago. Let us describe the method. At first, the original image will be covered with a regular, orthogonal net (or a grid). The whole image will be divided into smaller size squares. Next we construct an anamorphic image of the net and project it onto a specific surface. The distorted net drawn on this specific surface will discipline the distortions of the original image by smaller portions, which are the cells of an original image inscribed into particular net cells. Distortion type and size depends on the applied projection method (usually it is a central projection), on the type of the surface used to be covered with the distorted image (for surface anamorphs), and on the shape of the mirror used to create a mirror anamorph. This part of research will focus on folded superficial anamorphs (or surface anamorphs as it has been specified in earlier publication [8]). In particular, the consideration will relate to surfaces of a concave or convex cylinder of revolution and to a cone of revolution. The paragraphs below describe geometrical construction for certain deformation nets of originally orthogonal grids assigned to images.

2. Deformation net construction for convex cylindrical anamorphs

Deformation net for a convex cylindrical anamorph will be created as it is presented in Fig.1, while Fig.2 shows its planar development. In order to determine the deformation net in Monge projection we have specified: a cylinder of revolution with vertical axis l , the plane of a real image β and the station point (=observation point) Ob . Horizontal segments of the orthogonal grid, which belong to the lines $1, 2, 3, \dots$, will be centrally projected from point Ob onto the visible part of a cylinder's surface and designated respectively with $1^a, 2^a, 3^a, \dots$. These curvilinear segments are the segments of ellipses on the cylindrical surface (Fig.2).

Vertical segments of the orthogonal grid, which belong to the lines *I, II, III, ...* will respectively correspond to vertical directrices I^a, II^a, III^a, \dots on the cylinder surface in the described central projection. The development of the cylinder's surface will determine the anamorphic deformation net for the convex cylindrical anamorph with the specified dimensions. The development of the elliptical curves on the cylindrical surface will produce segments of sinusoidal curves. The central part of the convex cylindrical anamorph characterizes density intensification of the grid lines, which in consequence produces larger distortions of image areas close to the image borders.

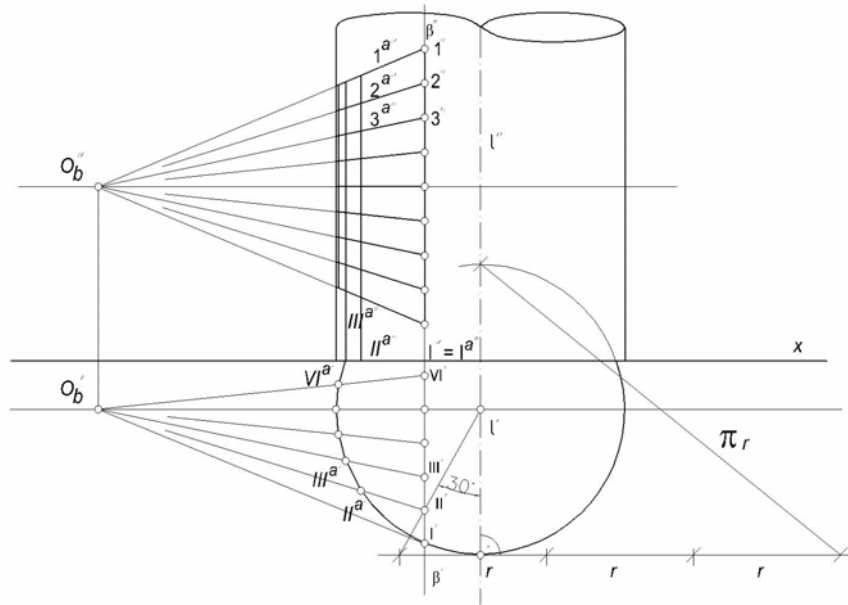

Fig.1: Geometrical principle for construction of the deformation net for a convex cylindrical anamorph

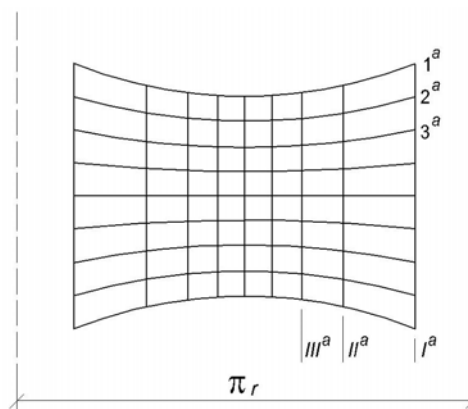

Fig.2: Deformation net for a convex cylindrical anamorph

3. Deformation net construction for concave cylindrical anamorphs

Deformation net for a concave cylindrical anamorph will be created similarly to the method presented above. The image of an orthogonal grid in central projection from point O_b will be created on a convex surface of a cylinder (Fig.3). The development of the cylinder's surface will produce the deformation net for the concave cylindrical anamorph (Fig.4). Vertical lines of the orthogonal net, which are parallel to directrices of the cylinder both in the

central projection as in the development, remain vertical. Horizontal lines of the orthogonal grid will create in the development the segments of sinusoidal curves. In the development we can observe lower density of the vertical grid lines in the central part of the grid (Fig.4).

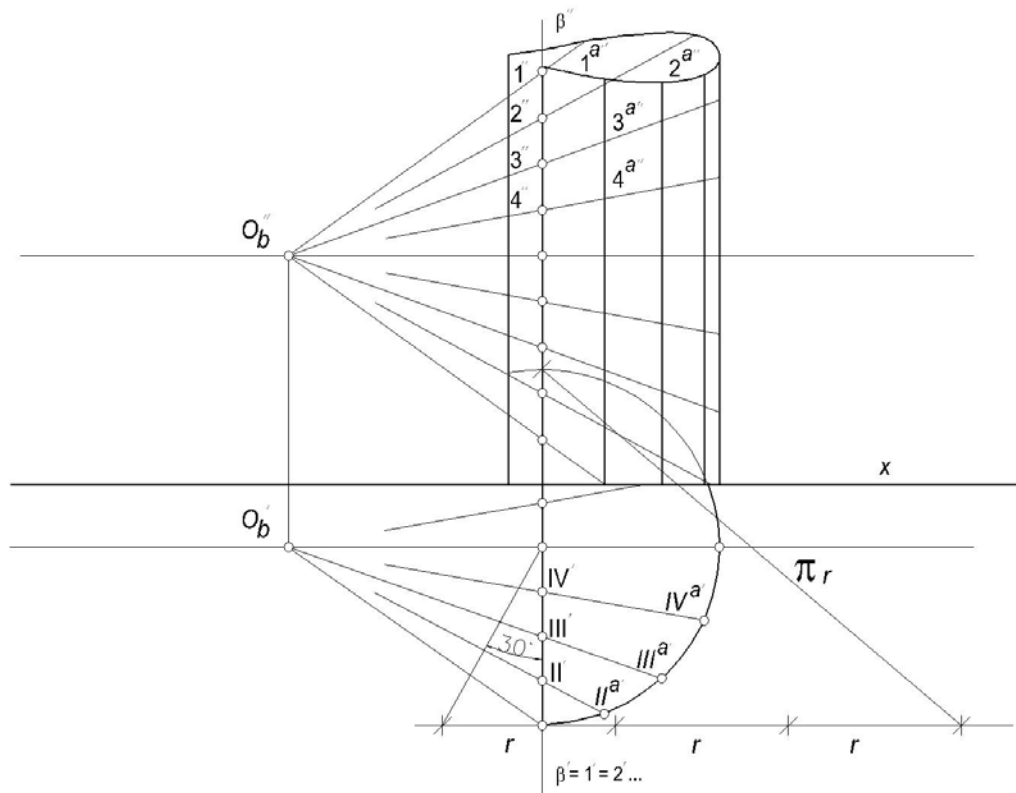

Fig.3: Geometrical principle for construction of the deformation net for a concave conical anamorph

The development of the cylinder surface will determine the anamorphic deformation net for the convex cylindrical anamorph with the specified dimensions (Fig.4). The central part of the convex cylindrical anamorph characterizes density intensification of the grid lines, which in consequence produces larger distortions of image areas close to the image borders.

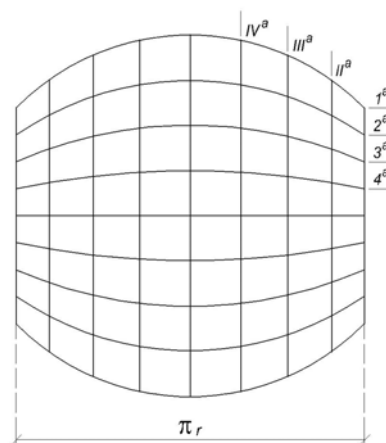

Fig.4: Deformation net for a convex conical anamorph

4. Deformation net construction for convex conical anamorphs

In order to simplify the construction of the deformation net for a convex conical anamorph it has been assumed that the grid assigned to the original image will be of circular

type. The grid create two families of lines. One family consists of radially deposited circles with the same center (co-centered circles with S center) and with equidistant growth of radiuses. The other family of the original grid lines creates the pencil of lines (S), which will be deposited at equiangular distances around the center S (Fig.5). It has been assumed that the right circular cone with the vertex W and the axis l will create the projection surface. The plane of the circular grid has been assigned perpendicularly to the cone axis l . Central projection of the assigned circular grid from point O_b onto the convex surface of the cone will produce the deformation net on its surface (Fig.5).

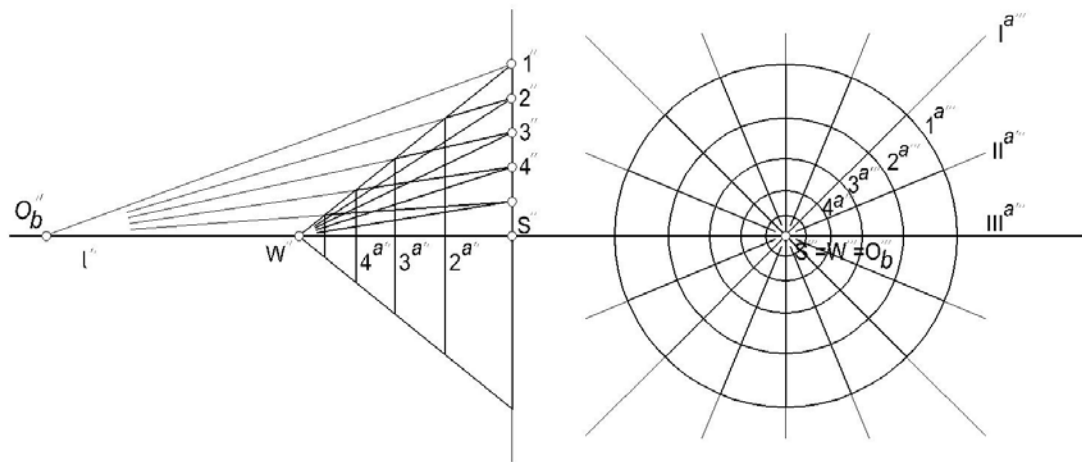

Fig.5: Geometrical principle for construction of the deformation net for a convex conical anamorph

The development of the cone surface will determine the anamorphic deformation net for the convex conical anamorph with the specified dimensions (Fig.6). The central part of the convex conical anamorph characterizes density intensification of the grid lines, which in consequence produces larger distortions of image areas around the image borders.

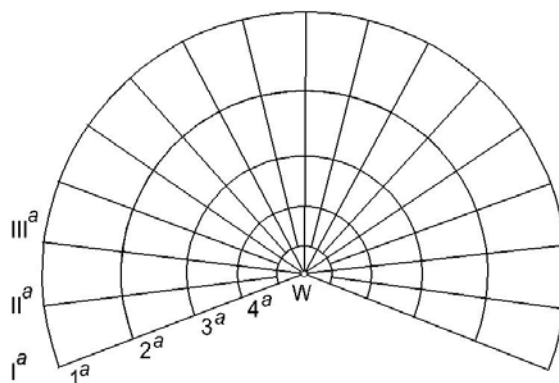

Fig.6: Deformation net for construction of a convex conical anamorph

5. Deformation net construction for concave conical anamorphs

The principle for construction of a deformation net for a concave conical anamorph has been presented in Fig.7. Let us consider a circular grid lying in the plane β and assigned to the original image as it has been described above (Fig.5). The plane is perpendicular to line l . Let us centrally project the grid onto the convex surface of the cone from the station point O_b lying on the axis l of this cone.

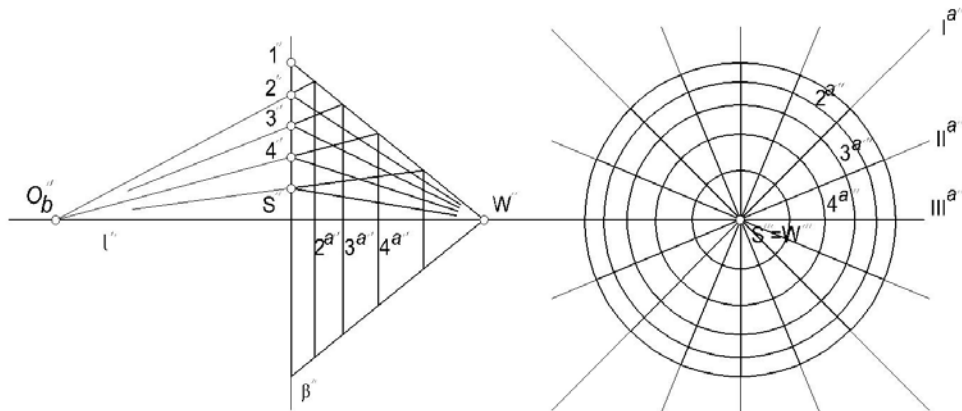

Fig.7: Geometrical principle for construction of a concave conical anamorph

The development of the cone surface, which includes the image of a grid obtained in a central projection will produce the deformation net with the deformations which increase in direction to the net center (Fig.8).

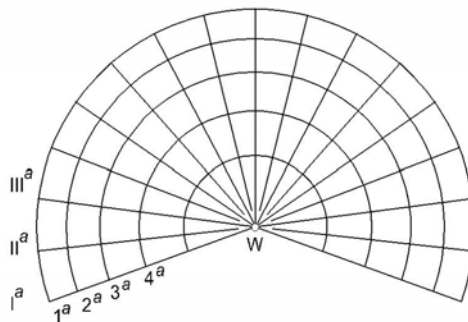

Fig.8: Deformation net for construction of a concave conical anamorph

The principles for creation specific deformation nets will find their application into creation of specifically distorted anamorphic images.

In subsequent publications the author will provide further discussion on construction of another deformation nets that have been described and classified in [7].

References

- [1] Bartel K.: *Perspektywa malarska*, Vol. II, F. Otto, PWN, Warszawa, 1958
- [2] Cole A.: *Perspektywa – świadectwa sztuki*, transl. Bończyk A., Wydawnictwo Dolnośląskie, Wrocław, 1995.
- [3] Zdziarski A., Dyduch T.: *Pewne algorytm odbić lustrzanych*, Proceedings of the Conference Geometry and Computer, Wisła 1995.
- [4] Folga-Januszewska D.: *Perspective, Illusion, Illusionism*, Projekt No 143 KAW, Warszawa 1981.
- [5] *Figaroscope*, supplement to Le Figaro, Dec.1995.
- [6] Zdziarski A.: *Anamorphic Transformation of Space Elements Aided with the Deformation Net*, Proc.7th ICECGDG, Kraków, 1996.
- [7] Zdziarski A.: *Klasyfikacja i nazewnictwo obrazów anamorficznych* - biuletyn PTGiGI-No15, Grudzień 2005.
- [8] Zdziarski A.: *Siatki deformacyjne anamorfoz powierzchniowych cz. I* - biuletyn PTGiGI-No17, Grudzień 2007.

SIATKI DEFORMACYJNE ANAMORFOZ POWIERZCHNIOWYCH: WALCOWYCH I STOŻKOWYCH

Opracowanie jest kontynuacją tematu przedstawionego w publikacji [8]. Wprowadzając w problematykę należy stwierdzić, że siatki są jednym z najprostszych i od dawna znanych sposobów przenoszenia bądź powiększania obrazów. Będą one miały również zastosowanie w konstruowaniu specyficznie odkształconych obrazów anamorficznymi. Jeżeli na rzeczywisty obraz nałożymy siatkę ortogonalną to uzyskamy jego podział na kwadraty będące poszczególnymi polami siatki. Konstruując anamorficzny obraz takiej siatki otrzymamy siatkę reformacyjną, która zdyscyplinuje deformację obrazu w nią wpisywanego. Zasada budowy poszczególnych siatek anamorficznymi będzie powiązana z rodzajem powierzchni dla anamorfozy powierzchniowej, bądź rodzajem lustra dla anamorfozy refleksyjnej. W niniejszym opracowaniu do rozważań przyjęto anamorfozy powierzchniowe, zwijalne, w zakresie powierzchni walca obrotowego wypukłego i wklęsłego oraz powierzchni stożka obrotowego wypukłego i wklęsłego, zgodnie z przyjętą klasyfikacją i nazewnictwem [7]. W opisanych przykładach przedstawiono geometryczną konstrukcję anamorficznej deformacji siatek ortogonalnych.