

Dorota KUCHTA¹
Dimitris DESPOTIS²
Kazimierz FRĄCZKOWSKI¹
Stanisław STANEK³

APPLICATION OF DATA ENVELOPMENT ANALYSIS FOR THE EVALUATION OF IT PROJECT SUCCESS

The paper is devoted to the problem of IT project success definition and measurement seen against the background of IT human resources management organisation. A review of the state of art of the problem shows that the assessment of IT project success is highly equivocal and subjective. Various methods may produce conflicting results. The paper proposes basically one novelty: an original approach to IT project success evaluation based on Data Development Analysis (DEA). DEA has been developed and used for years, but for other purposes. The new method, contrasted with two other which are based on other philosophies, is applied to a sample of Polish IT projects. This application shows that the new method in some cases completely changes the optics and emphasizes such aspects of IT projects which are neglected by other methods. It also shows that a combination of the proposed method with other IT project measurement methods may substantially increase the fairness of IT project team members and managers' appraisal, and hence the motivation of human resources in IT projects.

Keywords: *IT project success, data envelopment analysis, IT project input, IT project output*

1. Introduction

Evaluation of IT project success is important for many reasons, but one of the most important ones is certainly the need of a fair assessment of project managers and project

¹Department of Computer Science and Management, Wrocław University of Science and Technology, ul. Łukasiewicza 5, 50-371 Wrocław, Poland, e-mail addresses: dorota.kuchta@pwr.edu.pl, kazimierz.fraczkowski@pwr.edu.pl

²University of Piraeus, Piraeus, Greece, e-mail address: ddespotis@gmail.com

³General Tadeusz Kościuszko Military University of Land Forces in Wrocław, ul. Czajkowskiego 109, 51-150 Wrocław, Poland, e-mail address: s.w.stanek@gmail.com

teams, the issue being closely linked to the problem of motivation and, generally, human resources management in IT organisations. As in IT projects humans are the most important resource and many IT companies have to face the problem of high migration and lack of experienced resources, it is extremely important to have a system of fair judgment which would help decision makers to decide which projects are to be seen as most and which as least successful ones in the given circumstances and against the background of similar projects implemented in the same company or country.

Assessing project success has been the object of extensive research for many years, but no unique and definite method has been developed so far. For IT projects, the answer to the question “how to understand project success” has not been finally given as well. Probably everybody, even those who have not participated in any IT project, is aware of the existence of the many IT systems which have been completed on time, within budget, and according to specification, but which ultimately dissatisfy their end users. Such projects are, according to numerous researchers and practitioners (including the Standish Group, e.g., [6]), a success because of the compliance with golden triangle principle (planned time-cost-scope have been kept), but there is obviously something wrong with this statement. According to the authors of the present paper, the problem is that the notion of IT project success is extremely complex and IT project success assessment should take into account the circumstances and the context of the project implementation, as well as subjective opinions of various stakeholders [13]. It is only once when this condition is fulfilled that IT project managers and teams will be assessed in a fair way and motivated to implement the projects for the benefits of their organizations, whatever these benefits in each case are.

Thus, the goal of the paper is to propose a new approach to IT project success assessment based on an application of DEA (data envelopment analysis) method, which would allow to evaluate IT projects in the fairest possible way, taking into account the context and the point of view of project managers, project teams, as well as other stakeholders. The DEA method has been used to assess projects, also IT projects but in a different setting: in order to assess their efficiency, juxtaposing what has been consumed or sacrificed by the project with its outputs. To the knowledge of the authors, no application of the DEA method to the assessment of project success has been proposed in the literature so far. The new method will be applied, along with two other methods (which, although in fact also constituting original approaches to assessing project success, will serve basically as reference points, as representatives of several approaches to project success definition and measurement known from the literature), to the successful evaluation of a real world IT projects sample from Poland to serve as an initial validation of the method.

The outline of the paper is as follows: in the second section, a literature review of project success understanding, with emphasis on IT projects, will be presented. The third section will offer a short introduction to DEA method and a brief survey on the existing applications of DEA to project assessment. The emphasis will be again on IT

projects, and research projects will also be referred to, because they have many common features with IT projects: the desired end product is often only roughly known at the project start, substantial changes in the project scope are frequently necessary, and projects terminated on time, within budget and according to specification, are often not considered to be successful by the end users of the project product [25]. In the same section, a new method for assessing project success will be described, together with two reference methods. In the fourth section, a sample is presented and research steps described. In the fifth section, the results of the application of the proposed method to the IT project sample are presented and discussed. The paper finishes with some conclusions and proposals for further research.

2. Defining success in IT projects

The first aspect discussed here is the definition of a successful IT project which is far from unequivocal. Project success (to begin with, we will consider all projects, not just IT projects) can be and is defined in the literature in many different ways. Numerous authors suggest that a project is successful if it meets the specification (scope), cost (budget), and time (deadline) requirements. This “iron triangle” is viewed as the most basic level of project success [23], although many authors (e.g., [9]) use only time and budget as project success measures. However, numerous authors (e.g., [2, 3, 5, 7, 27, 30, 32, 37]) expand this definition substantially, introducing other project success measures. The nature of these extensions can be summarised by the following statement: *There have to be two groups of project success measures: objective measures (such as time or cost) and subjective measures (such as the satisfaction of different project stakeholders)* [7]. Subjective measures are necessary because the perception of project success depends strongly on the assessor (e.g., [13]).

The literature about project success dedicated to IT projects is in line with these extensions: usually – with very few exceptions, including the Standish Group, for which only cost, time, and content count [6] – not only objective but also subjective measures are proposed (e.g., [10, 18]). For example, Cow and Cao [10] measure IT project success in four independent dimensions: quality (judged subjectively by the customer), scope (objective measure), time (objective measure), and cost (objective measure).

Other literature items on IT projects also introduce such subjective measures as the satisfaction of the project team or the project manager. The latter is especially important in the case of Agile managed IT project. In every definition of that project, the customer plays an extremely important role [33, 38, 39].

The other question about project success evaluation is the method of aggregating various success dimensions adopted. In other words, should the various aspects be synthesised into one measure, by taking, e.g., a weighted average, which would evaluate

the project success generally – by giving one number, standing for the degree to which the project was successful, according to the suggestion of Shashi et al. [35] or should the different aspects be left separate which is proposed by Cheng et al. [9], who, although using only time and budget as project success measures, differentiate the two dimensions of project success, and by Chow and Cao [10], who do not synthesise their four dimensions of project success but measure them separately? Both approaches have their advantages. Here, however, taking into account the interest of managers who need concise information about their projects, we will strive to have one single number for each project which would represent its success evaluation. On the other hand, we will make an attempt not to lose the flexibility of project success evaluation offered by the other approach where the decision maker can decide in each case about the importance of various aspects of project success (in some cases keeping, e.g., within budget may be most important, in other cases the hard measures (time, cost) may count much less than customer satisfaction). In order to achieve a balance of the two seemingly contradictory approaches, we will apply to our best knowledge for the first time the DEA to IT project success evaluation, described shortly in the second section. As an alternative allowing one to evaluate the proposed method, we will also propose two other measures of IT project success.

Additionally, project achievement in different aspects can have a stepwise nature. For example, the deadline or the budget can be exceeded by 10% or 70%, which does make a difference. What degree of achievement in the different aspects of IT project implementation is considered a success, a failure, a near success, a partial success, and so on, should be decided by the decision maker in each individual case. In the literature, various approaches are proposed. For example, Yourdon [41] is of the opinion that 50% “less” or “more” than planned in a negative direction in any of the IT project success parameters means complete failure (e.g., 50% less scope, more money, more time, or less quality). Cheng et al. [9] propose a lower bound of 80–90% in the achievement of the quality and scope as the minimal requirement for an IT project to be considered successful. In [29], project success is divided into 4 categories with respect to time and 4 categories with respect to the cost of the project: the achievement of 5% within the set limit (time or cost), exceeding the limits by 5–15%, 15–30% or more than 30%. In Frączkowski and Karwacka [20], the Nahod et al. [29] approach is completed by subjective qualitative evaluation made by the customer (very low, low, medium, high, and very high satisfaction). In our proposal we will keep the nuanced, stepwise evaluation of project success in all its dimensions.

Taking into account what has been said above and the specificity of IT projects where there is often a discrepancy between the success in terms of time, cost, and scope actually implemented and the customer satisfaction, we will understand IT project success as an aggregated success in terms of time, cost, scope, and customer satisfaction. However, the decision maker can select other IT project success dimensions, as our

approach will be universal and will allow one to introduce any IT project success dimensions admitted by the decision maker. Naturally, for each selected project success dimension a project success measure has to be determined.

The objective of the present paper will be to propose an aggregation method of the evaluations of four selected success dimensions (time, cost, scope, customer satisfaction) into one IT project success indicator, keeping in mind the need of flexibility in assigning weights to the individual IT project success dimensions. This proposal will use DEA and will be described in the second section, following basic pieces of information about DEA.

3. Data envelopment analysis in IT project assessment

Data envelopment analysis (DEA) was proposed by Charnes et al. [8]. The goal of this proposal was to measure the efficiency of so-called decision making units (DMUs), which might be production departments, bank branches, hospital wards, and, last but not least, projects. The efficiency of a unit is defined as follows:

$$\text{Efficiency} = \frac{\text{weighted sum of outputs}}{\text{weighted sum of inputs}} \quad (1)$$

The inputs are basically the resources consumed by the unit (e.g., human and financial resources, time used, raw material or utilities consumed, etc.), and the outputs are basically the goods or services produced or delivered by the unit (e.g., in the case of a bank, we would have credits granted, deposits and accounts sold, etc.). The goal of each unit should be to maximise its efficiency.

The idea of DEA is that the DMUs should be assessed in a relative way, i.e., with respect to a selected set of DMUs. For example, a Polish branch of a bank X should usually be evaluated with respect to other Polish branches of the same bank, ignoring, e.g., French or Russian branches. Its evaluation might change dramatically if it was assessed against all European branches of the same bank. The other idea of DEA is that each DMU, while being assessed, can choose its own weights for the weighted input total and the weighted output total in formula (1), which are then applied to all the DMUs, and allow in this way the DMU being evaluated to obtain the maximal possible efficiency according to formula (1), using all possible values of weights. Here we find the flexibility in units assessments that we mentioned in the previous section with respect to project success evaluation. Naturally, it might be difficult to say, generally, which outputs of a bank branch would count most and the minimisation of which resources usage would be most desired in a given context. Thus, each DMU can choose the weights assigned to individual inputs and outputs in order to show itself in the best

light. If even having this possibility, it compares badly with the other DMUs from the set of DMU's that is used for comparison, it is certain that it cannot be judged as highly efficient. The mathematical programming model used in DEA is as follows:

$$\frac{\sum_{j=1}^J v_j^0 y_j^0}{\sum_{i=1}^I u_i^0 x_i^0} \rightarrow \max \quad (2)$$

$$\frac{\sum_{j=1}^J v_j^0 y_j^k}{\sum_{i=1}^I u_i^0 x_i^k} \leq 1, \quad k = 1, \dots, K \quad (3)$$

$$u_i^0 \geq 0, \quad v_j^0 > 0$$

where x_i^k ($i = 1, \dots, I$) are inputs of the k th DMU, $k = 0, \dots, K$ and y_j^k ($j = 1, \dots, J$) are its outputs, u_i^0 ($i = 1, \dots, I$), and v_j^0 ($j = 1, \dots, J$) decision variables and at the same time weights of the inputs and outputs, respectively, chosen from the point of view of the 0th unit in order to maximise its efficiency, defined in (1). Computation issues of solving model (2), (3) are discussed in the relevant literature (the most important issue is reducing model (2), (3) to a linear programming problem, which is possible and described in the literature, e.g., [8, 12]).

Each unit becomes, in turn, the 0th unit. The value of the objective function (2), formulated when the k th unit becomes the 0th unit, will be denoted as p_k and considered to be the performance measure of the k th unit. The units are then ranked in the decreasing order of p_k ($k = 0, \dots, K$). The maximal possible value of p_k is 1 and it indicates the units which can be considered to be fully efficient as compared to the selected set of reference.

DEA has been the subject of vast research in which modifications of the original model are considered. For example, the original model (2), (3) was designed for cardinal values of the inputs and outputs. When ordinal values occur, a modification described by Cook and Zhu [11] is used, and it will also be necessary in case of the application of the proposed method in Section 4. DEA has been extensively applied not only to bank, hospital or production units but also to project evaluation. For example, in Gładysz and Kuchta [21], based, among others, on Eilat et al. [17], a summary of literature findings of DEA application to research project efficiency evaluation is presented. Figure 1 shows the inputs and outputs used with respect to research projects. In e.g., [26, 34], and [42] a similar synthesis has been performed for DEA applied to IT projects.

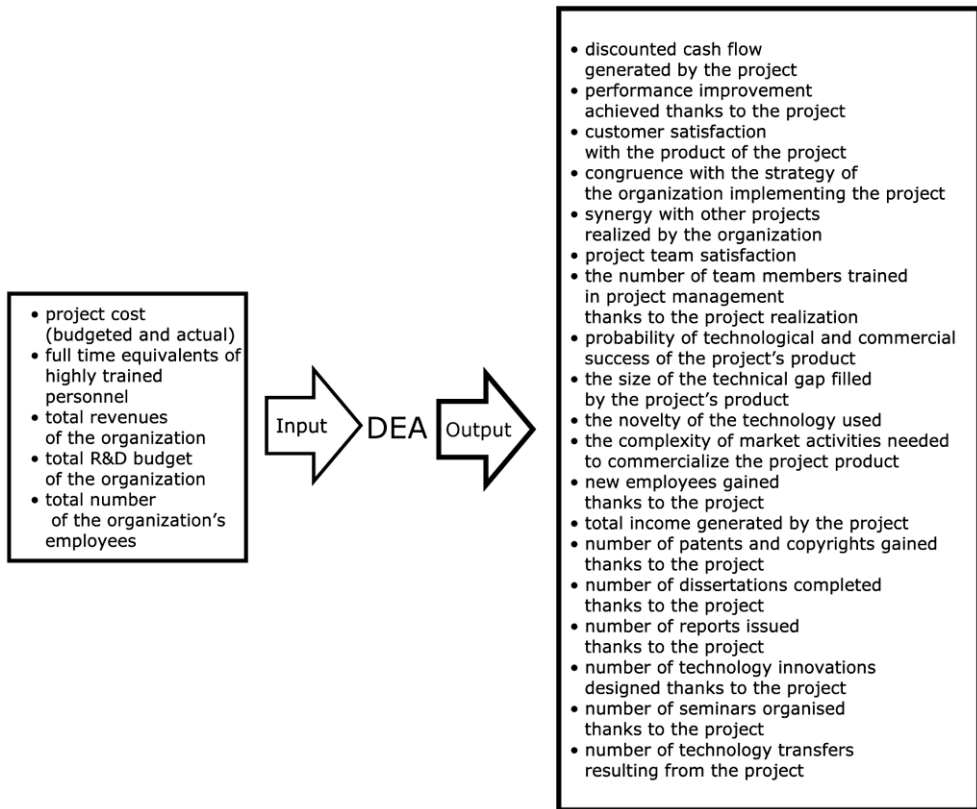

Fig. 1. Synthesis of existing DEA models for research projects (based on [21])

In the existing DEA models applied to projects, the original aim of DEA was preserved: the maximisation of project efficiency, measured according to formula (1), where, basically, the project inputs represent the elements which have to be consumed or sacrificed in order to implement the project, and the outputs are benefits of various types generated thanks to the project (see Fig. 2). Here we propose to use the DEA model in another way, in order to turn it into an IT project success measure. Thus, we propose to define IT project success indicator P in the following way:

$$P = \frac{\text{weighted sum of success dimensions measures maximised}}{\text{weighted sum of success dimensions measures minimised}} \quad (4)$$

The process of project success evaluation would take a similar form as the evaluation of DMUs efficiency. The set of IT project to be analyzed would be selected, against which the success of each individual project would be evaluated. Its cardinality would be

$K + 1$. Model (2), (3) will be used, where x_i^k ($i = 1, \dots, I$) would represent the values of the selected success dimensions measures which are minimised for the k th project, $k = 0, \dots, K$ and y_j^k ($j = 1, \dots, J$) would represent the values of the project success dimensions measures to be maximised for the same project. u_i^0 ($i = 1, \dots, I$) and v_j^0 ($j = 1, \dots, J$) would be the weights of individual project success dimensions, chosen from the point of view of the 0th project.

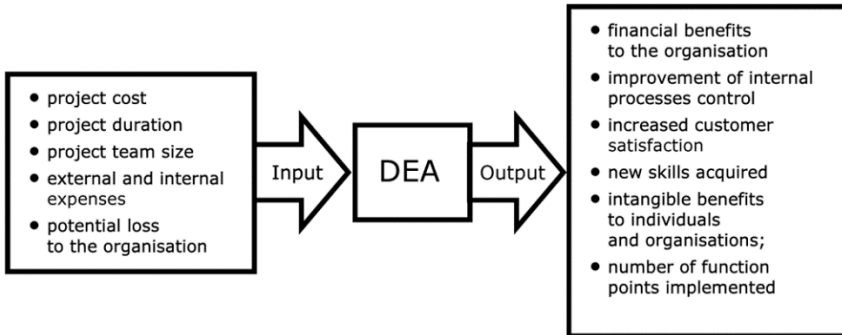

Fig. 2. Synthesis of existing DEA models for IT projects

This approach to project success evaluation fulfils the conditions set as the goal of the present paper: on the one hand, project success will be measured by means of one aggregated number, but, on the other hand, this measurement will be flexible: the weights of individual project success dimensions are not pre-set, but will be fixed for each project, in order to present it in the best light against the background of other projects from the selected projects set. The projects which after this evaluation process will have a low p_k value (which will represent the maximal value of (4) for the k th project) can be considered as certainly unsuccessful with respect to the selected projects set. This method will allow the manager to divide his or her projects into two sets: one of potentially successful projects, and one of certainly unsuccessful projects. Further in-depth analysis of each project would obviously be needed, but the decision maker will have a useful basis of two projects sets as a starting point. As it will be shown in the application part of the present paper, a more nuanced division into 3 or 4 groups of projects will be also possible.

In this paper, we consider IT projects and, as mentioned above, four success dimensions: two quantitative ones (time and cost) and two qualitative ones (scope and customer satisfaction). For these project success dimensions, we propose to use the following measures:

- x_1^k will stand for the ratio $\frac{\text{actual budget}}{\text{planned budget}}$ of the k th project, $k = 0, \dots, K$ (cardinal values),

- x_2^k will stand for the ratio $\frac{\text{actual duration}}{\text{planned duration}}$ of the k th project, $k = 0, \dots, K$ (cardinal values),

- y_1^k will stand for the percentage of planned scope actually implemented of the k th project, $k = 0, \dots, K$ – this value will have to be given by the project manager (cardinal values),

- y_2^k will stand for the satisfaction degree of the customer of the k th project, $k = 0, \dots, K$ – this value is usually known, in a more or less veiled form, to the project manager, who will have to express it in a selected, unique scale (ordinal values).

Obviously, the selection of the first two project success measures above takes for granted that two assumptions are fulfilled:

- project time and cost estimation is performed in accordance with the state of art of IT project estimation (see, e.g., [1]) and using the best knowledge of the project team and the organisation,

- any reduction of project cost and duration is achieved not at the cost of project product quality.

The above proposal will be applied in section 4 to a sample of Polish projects whose managers took part in a survey based on questionnaires.

4. Research sample, the questionnaire and procedure

The survey was conducted in the period of time from April 10th, 2010 to June 15th, 2010. The research was supported by the Polish Information Processing Society, the Project Management Society, and the Institute of Computer Science of the University of Wrocław. A questionnaire was prepared with the aim to analyse the problem of IT project success understanding and the factors which influence IT project success.

While designing our research, it was assumed that:

- the research should have a nationwide scope and should cover as many projects as possible,

- the respondents should be project managers,

- the questions should be formulated in such a way so that the project manager would be able to answer them without having to spend much time consulting the project documentation or other people. We also asked project managers to give the opinions of the customers, which, as the projects terminate, they should know fairly well,

- the time necessary to answer the questions should not exceed 15 minutes,

- the answers should be anonymous,
- the questions should be easily accessible (on a website),
- the questions should explore, as much as possible, measurable facts, and opinions should be gathered only when necessary,
- the final results of the analysis of all the projects should be returned to the respondents to form valuable feedback for them.

381 responses were received, of which 14% came from the public sector and 86% from the private sector. Strict criteria for validating results were adopted. It turned out that a number of responses were incomplete or did not meet the criteria of substantive correctness. Finally, 79 opinions, corresponding to 79 different projects, were qualified for further analysis. They are indexed by t , $t = 1, \dots, 79$.

Among the information items required were, among other, items about:

- planned and real time of implementation,
- planned and real cost,
- percentage of the realized scope,
- satisfaction of the client and project manager in a four-level scale: low, rather low, rather high, high (grades provided by the project manager),
- numerous features of the projects, potentially helpful to identify project success factors, among others, the type of product the given IT project was to deliver, competences of the project manager and the project team, management methods and tools used in the project and in the organisation, type of communication with the customer, etc. Results regarding project success factors for the sample can be found in [19].

Table 1. Definition of the variable corresponding to the project size

duration \leq 1 month, then $TC = 1$
1 month $<$ duration \leq 3 months, then $TC = 2$
3 months $<$ duration \leq 6 months, then $TC = 3$
6 months $<$ duration \leq 12 months, then $TC = 4$
duration $>$ 12 months, then $TC = 5$

Table 2. Definition of the variable corresponding to the project budget

budget \leq 100 000 PLN, then $BC = 1$
100 000 PLN $<$ budget \leq 500 000 PLN, then $BC = 2$
500 000 PLN $<$ budget \leq 1 000 000 PLN, then $BC = 3$
1 000 000 PLN $<$ budget \leq 5 000 000 PLN, then $BC = 4$
Budget $>$ 5 000 000 PLN, then $BC = 5$

For each project its size was estimated, on the basis of the project duration and project budget, according to the formula $PS = \left[\sqrt{TC \times BC} \right]$, where TC is the project

class according to the time criterion (Table 1), BC stands for the project class according to the planned budget criterion (Table 2) and the symbol $[x]$ stands for the entier of x . TC , BC and consequently PS take values from the set $\{1, 2, 3, 4, 5\}$.

Five project categories are distinguished:

1. Microprojects ($PS = 1$, 28% of the sample).
2. Small projects ($PS = 2$, 30% of the sample).
3. Medium-sized projects ($PS = 3$, 2% of the sample).
4. Large projects ($PS = 4$, 35% of the sample).
5. Very large projects ($PS = 5$, 5% of the sample).

The planned duration of the examined projects ranged from 1 to 60 months, and the planned budget was within the limits of 9500–8 000 000 PLN. The project teams consisted of 2–80 members.

Model (2), (3) was applied to the three most numerous categories of projects from the sample (category 1, 2, and 4) because it was considered reasonable to compare projects within their corresponding size categories.

The research procedure for each category was as follows:

I. Model (2), (3) was repeatedly implemented for each project from the given category, indexed by k , $k = 0, \dots, K$ (each project, in turn, became the 0th project), where $K + 1$ is the cardinality of the given category). The results denoted as p_k give the maximal success indicator value for the k th project. If $p_k = 1$, we are dealing with potentially fully successful projects within the given category, or at least decisively more successful than the other projects in the category. Naturally, in a further analysis it has to be decided whether the weights assigned by the algorithm solving model (2), (3) to individual project success dimensions for the projects with $p_k = 1$ were acceptable but a preliminary set of successful project was identified. Projects from this set will be represented as belonging to the 4th success layer, and their success degree determined in this way will be set to 4 ($SD_k^1 = 4$).

II. The given category was then reduced by removing project belonging to the 4th success layer. The reduced category was then analysed in the same way. Projects belonging to 3rd success layer are those for which $p_k = 1$ in this step (for them, we will have $SD_k^1 = 3$, they were the most successful ones among all the projects in the considered category except for the potentially fully successful projects).

III. Second success layer was found in the analogous way ($SD_k^1 = 2$).

IV. Projects belonging to none of the success layers 4, 3, 2 were considered potentially unsuccessful with respect to the given category, and thus assigned to success layer 1 ($SD_k^1 = 1$).

V. All the projects from the given category were then analysed using two other project success evaluation methods (playing the role of reference methods, referred to as method B and C, while the main method, based on DEA, will be referred to as method A). The goal of this step was to evaluate the usefulness of the proposed approach. Method B is based

on the [29] proposal and logical conjunction and negation, and it is not relative, i.e., the result does not depend on the set of projects selected for evaluation. This method serves here as a reference method, as a representative of all the project success definitions which aggregate the degrees to which the project is successful in various success dimension into one indicator, which can be formulated linguistically (e.g., full success, partial success, partial failure, complete failure). Method C utilises the same idea as the method based on DEA (method A), but with fixed weights in (1). It is another reference point here: it serves as a representative of all the methods where project success evaluations in various aspects are aggregated into one formula using weighted arithmetical operations with fixed weights.

The first alternative proposal is formulated in Table 3. The tolerance ranges for variances of project duration, budget and scope (in the negative directions) are taken from [29] and, consequently, are fixed (contrary to method A). The success degrees in the last column of Table 3 are defined by the authors of the present paper. Naturally, many other definitions would be admissible in this place and can be chosen by the decision maker.

Table 3. A proposal of IT project success definition based on [29] and logical conjunction and negation (proposal B)

Conditions to check for the k th project	The k th project evaluation (SD_k^2)
$C_a : x_1^k \leq 105\% \wedge x_2^k \leq 105\% \wedge y_1^k \geq 95\% \wedge y_2^k = 4$	full success (4)
$C_b : \neg C_a \wedge x_1^k \leq 115\% \wedge x_2^k \leq 115\% \wedge y_1^k \geq 85\% \wedge y_2^k \geq 3$	partial success (3)
$C_c : \neg C_b \wedge \neg C_a \wedge x_1^k \leq 130\% \wedge x_2^k \leq 130\% \wedge y_1^k \geq 70\% \wedge y_2^k \geq 2$	partial failure (2)
$C_d : \neg C_c \wedge \neg C_b \wedge \neg C_a$	complete failure (1)

As another reference method of project success evaluation (called henceforth method C), we will use formula (5), where the same idea as in formula (1) is used for project evaluation, but the weights are fixed (equal for all the project success dimensions, y_2^k is normalised in order not to exceed 1, the condition that is already fulfilled by x_1^k , x_2^k and y_1^k).

$$S_k = \frac{y_1^k + \frac{y_2^k}{4}}{x_1^k + x_2^k}, \quad k = 0, \dots, K \quad (5)$$

In the interval $[\min_{k=0, \dots, K} S_k, \max_{k=0, \dots, K} S_k]$ the quartiles Q_1, Q_2, Q_3 were determined and the success indicator SD_k^3 was calculated as follows:

Table 4. A proposal of IT project success definition based on the idea from (1) but with fixed weights (proposal C)

$S_k \in [\min_{k=0, \dots, K} S_k, Q_1]$	$SD_k^3 = 1$
$S_k \in (Q_1, Q_2]$	$SD_k^3 = 2$
$S_k \in (Q_2, Q_3]$	$SD_k^3 = 3$
$S_k \in (Q_3, \max_{k=0, \dots, K} S_k]$	$SD_k^3 = 4$

5. Results of the application of the proposed method to the research sample

Below, due to the size limitations of the paper, only the results for Category 1 will be presented; in those for Category 2 and 4 there occurred exactly the same phenomena and they confirm the findings for Category 1. As defined above, Category 1 represents the microprojects.

In Table 5, the projects in bold are those where there is at the minimum one difference equal to at least 2 among the pairs formed by the three columns named SD_k^1 (method A), SD_k^2 (method B), SD_k^3 (method C). These projects' success is evaluated in a significantly different mode by at least two of the three approaches. The projects are analysed below.

- In the case of project 10, method A, the one using the DEA model, gives a substantially different evaluation with respect to the other two methods. This is due to the fact that method A allows for each project "its own" weights in formula (2), which maximise its evaluation. Project 10 is characterised by a high delay, it took 2,67 longer than planned. However, it was possible in case of method A to give higher weights to the other dimensions of project success, which were much better for project 10 (the cost of this project was cut down by 15% with respect to the initial budget, all the scope was implemented and the satisfaction of the customer was at the highest possible level). The other methods have fixed weights and the delay counts in them as much as the other success dimensions. Method A, DEA based, made it possible for the decision maker to notice that project 10 is different than the other projects evaluated to be unsuccessful by methods B and C. It is different because delay is its only "sin" – and it is quite good in the other success dimensions. Naturally, it is possible that the decision maker decides that the delay was unacceptable and the project cannot be seen as successful, but it is also possible that method A draws attention to what is probably more essential than timeliness: customer satisfaction, full scope implementation, and financial savings. All depends on the circumstances. We are dealing here with microprojects: it is possible that savings are insignificant but delays mostly disadvantageous, it may also be the other

way round. Whatever the case, the proposed method managed to distinguish a project which at least theoretically might be considered as successful, but methods B and C downplayed it completely. If method A was not applied, the project would automatically fall into the worst class, which might be unjust to the project manager and the project team.

Table 5. Results for projects from Category 1
(sorted decreasingly on SD_k^1 and, as a second criterion, on p_k)

k	x_1^k [%]	x_2^k [%]	y_1^k [%]	y_2^k	p_k (only from step I)	SD_k^1 (A)	SD_k^2 (B)	SD_k^3 (C)	$\max_{m=1,2,3} SD_k^m$
9	100	50	100	4	1	4	4	4	4
10	85	267	100	4	1.00	4	1	1	4
13	95	108	95	4	1.00	4	3	4	4
15	83	107	100	3	1.00	4	3	4	4
12	100	100	100	4	0.97	3	4	4	4
17	87	108	85	2	0.96	3	2	2	3
6	107	109	100	3	0.83	2	3	4	4
16	120	150	100	4	0.79	2	1	3	3
2	125	100	85	3	0.74	2	2	3	3
18	100	150	95	3	0.83	1	1	2	2
21	108	114	100	3	0.81	1	3	3	3
20	111	120	95	3	0.78	1	2	3	3
7	117	122	100	3	0.75	1	2	3	3
3	120	125	85	3	0.73	1	2	2	2
11	120	133	100	3	0.72	1	1	2	2
4	130	150	100	3	0.66	1	1	1	1
14	130	175	100	3	0.64	1	1	1	1
0	133	250	85	2	0.62	1	1	1	1
19	142	167	95	3	0.60	1	1	1	1
5	160	200	100	3	0.53	1	1	1	1
8	250	117	95	3	0.43	1	1	1	1
1	200	233	100	2	0.43	1	1	1	1

- Project 6. Here we are facing the case in which the proposed method (method A) evaluates project success much worse than method C (in method C the weights are fixed and equal, in method A they are determined separately for each project). The reason for this discrepancy is the fact that projects 9, 10, 13, 15, 12, and 17 had in method A the possibility to stress more their best success dimensions (savings of time and money in case of projects 9, 10, 13, 15, and 17 or a high customer satisfaction degree in case of projects 9, 10, 13, and 12) to look better as compared to project 6. Project 6 has no savings (neither in time nor in money) and the satisfaction degree is in its case, not the highest. So, relatively, it is quite possible that its project manager and the project team

should be rewarded less than those of the projects ranked higher by method A. Obviously, all depends on the context and on how much different dimensions actually weight to the organisation implementing the project. That is why we also propose to take into account the last column of Table 5, which, thanks to the maximum operator, will provide more guarantee that project managers and teams will not be unfairly under assessed.

- The high difference of success degree of project 16 concerns methods B and C, and method A places this project between them. The low result given by method B is due to the fact that tolerances for overtime and over budget in method B are fixed and they are both exceeded by project 16. However, this project has good results in scope and in customer satisfaction, and this is reflected by the relatively high evaluation given by method C. Relatively, however, other projects with the same outcomes in scope and customer satisfaction (9, 10) are evaluated higher by method A and C, because in these two methods savings in time and cost count and are or can be assigned a high weight, whereas method B does not reward savings at all.

- Projects 7, 20, and 21 are evaluated by method A, and in terms of their success rate, they are placed substantially lower than by methods B and C. This is because these projects exceeded substantially their planned duration and budget and in the same sample there are, e.g., projects 15 and 6 with similar achievements in terms of scope and customer satisfaction, but with better results with respect to time and cost. Method A, which is based on a relative assessment, evaluates project 15 and 6 higher than projects 21, 20, and 7. The better results for projects 21, 20, and 7 given by method B are due to the fact that they do not exceed the most severe tolerances of method B and due to that in method B savings are not rewarded. Method C, by contrast, has fixed, equal weights for all the project success dimensions and these weights made the good sides of the three projects, i.e. scope and customer satisfaction increase the overall project success evaluation. However, if savings in time and cost are important, then the three projects 21, 20, and 7, seen against the background of the whole sample, should not be ranked highly and in this respect, method A gives a more correct result. At the same time, the last column of Table 5 gives a milder evaluation of project success for all the projects.

- All the projects 11, 4, 14, 0, 19, 5, 8, and 1, whose success is rated at the lowest level by all the three methods, should be seen as a clear case: they are a complete failure – neither flexibility weights nor mild tolerances have been able to save their image. The organisation managers should conduct their deep analysis to find the roots of the various types of problems these projects have caused.

The most striking examples are here projects 10 and 21. Project 10 would be evaluated as completely unsuccessful by both methods B and C that do not allow weights flexibility, because this project has a relatively big delay. Thanks to the proposed method A, decision maker's attention is drawn to the fact that, possibly, this project is not a complete failure: if we assign higher values to the other project success dimensions, i.e., cost savings, scope implementation, and customer satisfaction, this project

looks better and it seems that this might be correct. This project is certainly more successful than all the other projects evaluated at the lowest level by both methods B and C, and it is due to the proposed method that this becomes clear. Obviously, the final decision is taken by human beings, but it is fairly possible that the proposed method would “save” project 10 and its team from an unfair negative assessment.

Project 21 is the opposite case. Method A downplays this project with respect to methods B and C. The reasons for this phenomenon were explained above – the main conclusion was that if savings in time and cost do count much for the given organisation, then project 21 should not, in fact, be ranked as highly successful. The proposed method A draws attention to the fact that this project is actually less successful than, e.g., project 6 or 15, with better results with respect to time and cost and the same time with respect to scope and customer satisfaction. In order not to harm the project team, we can base our judgment on the last column of Table 5, but it is clear that the proposed method A is able to change the optics with respect to other project success assessment methods, with no flexibility in the weights assigned to individual success dimensions, and draw attention to the aspects of a specific project which are possibly neglected by the other methods.

It is important to underline the relative nature of method A, based on the DEA philosophy. The order based on column named p_k in Table 5 is changed by the order as based on SD_k^1 , although the values in both columns stem from method A. But those in column p_k were determined in Stage I, while all the microprojects were taken into account, while the success levels 1–3 from column SD_k^1 are the results of stages II–IV, where stepwise the best projects from each consecutive stage were removed and the remaining projects were evaluated among themselves. The method, like the DEA method, gives thus the possibility to benchmark our projects against a precisely selected sample.

6. Conclusions

The subject of the present paper is the problem of IT project success definition and measurement. The state of art in this domain is presented, and it can be summarised in one sentence: the notion of IT project success is extremely equivocal, subjective, and context-dependent. In an attempt to search for a solution to this problem, three new methods of measuring IT project success are proposed, whereas the main proposal is a quite innovative one: it is based on the data envelopment analysis, applied for years to relative efficiency assessment of units belonging to a selected sample (e.g., bank or hospital branches, but also projects). Here it is adapted to IT project success assessment. The method has the following advantages:

- It can make use of vast existing DEA theory and ready-made solvers (e.g., [12]), which can be applied without any modifications (the models used are taken directly from the original DEA, it is only the interpretation of variables, coefficients and results which is different).

- It is relative and allows benchmarking of IT projects against projects from the same department, company, country, of the same category, size, etc.

- It is based on the assumption that each project can choose the weights of the different IT project success dimensions, which takes into account the equivocal and subjective nature of IT project success.

- In some cases it gives a substantially different (although still justified) project ranking with respect to project success degree from other project success evaluation methods, which means that, combined with the other methods (like here, by means of the maximum operator, or by means of other operators and functions), it may guarantee a relevant decrease of harm – und thus demotivation – administered to IT projects managers and teams.

- It allows a free choice of various IT project success dimensions, both objective and subjective ones. The choice made in this paper is only an example.

Clearly, the proposed approach has several limitations which at the same time indicate further research possibilities:

- The sample on which it was initially verified was rather small in number. Unfortunately, it is rather difficult to persuade IT project managers to participate in a time consuming questionnaire-based research. Most papers treating the problem of IT project success are based on small samples (e.g., 24 projects [16], 42 projects [28], 40 projects [40]). In fact, the only research on IT project factors known to the authors of the present paper that is based on a big and representative sample and concerns IT projects, in general, is that conducted by the Standish Group [6]. However, the Standish Group uses only quantitative measures of IT project success. There are few other papers which are based on bigger IT project samples, but they refer only to Agilely managed IT projects [36, 33].

- The sample is probably rather diversified in nature and the scope of this feature is difficult to assess: some of the projects may have been Agilely managed ones and some in traditional ways. The question about agility-traditionality was not asked, as well as some other important questions (e.g., about the projects being part or not of transformational programmes or bigger business projects, etc.). Naturally, this is an important drawback, as the influence of IT project and project management type on the understanding and measurement of project success may be substantial. For example, there exists a rather numerous set of papers devoted to the IT project success problem uniquely with reference to Agile IT projects (see [4] for the state of art).

- The two reference methods (methods B and C) were an arbitrary choice: a comparison of the proposed method with a selection of other project success evaluation methods would be desirable, also those developed specifically for IT projects (e.g., [31]).

- The method was applied to a sample of Polish IT projects. Obviously, the best way to test the usefulness of the method would be to apply it to IT projects of one category (e.g., microprojects implementing a new system) realised by one organisation and combine it with a post-evaluation conducted by the project manager, project team, and organisation managers. Unfortunately, it was impossible to find a sufficiently big sample to fulfil this requirement. This is one necessary direction of future research, although the authors of the present paper know no paper based on IT projects implemented by one organisation.

- Another direction would be the choice of other IT project success dimensions, e.g., selected from those presented in Figs. 1 and 2 as inputs or outputs in the DEA models applied to project efficiency evaluation or based on project benefit management findings [24, 43]. In fact, the latter seems to be the main issue in project success definition and evaluation nowadays, as project benefits seem to be essential measures of project perception. However, the application of project benefit management to IT projects is still a blank field – in Scopus database only two papers referring to this subject are found [22, 36]. Thus, a combination of the proposed approach with project benefits management might be a further research path.

- Various extensions of the DEA method might be used, especially those allowing fuzzy or stochastic reasoning (see e.g., [15]). In the data we used in this paper, we did not have access to fuzzy or stochastic data, but, obviously, stochastic or fuzzy approaches allow to take the indeterministic nature of IT project evaluation and seem rather promising as a further research step.

- Other multiple criteria evaluation methods might be used in order to evaluate the sensitiveness of the results. As is shown in [14], no substantial differences should be expected, but certain differences in the project ranking might occur, which in some cases may be important to the managers and would have to be discussed.

The problem of IT project success is extremely complex and sensitive, as oftentimes it conditions the IT projects team members and managers' appraisal and career development, and various approaches to IT project success measurement give conflicting results. We hope that the present paper provides a modest element to solve this problem.

References

- [1] ABRAN A., *Software project estimation: The fundamentals for providing high quality information to decision makers*, Wiley-IEEE Computer Society, 2015.
- [2] ASHLEY D.B., LAURIE C.S., JASELSKIS E.J., *Determinants of construction project success*, *Proj. Manage. J.*, 1987, 18 (2), 69–79.
- [3] BACCARINI D., *The logical framework method for defining project success*, *Proj. Manage. J.*, 1999, 30 (4), 25–32.
- [4] BERGMANN T., KARWOWSKI W., *Agile project management and project success: A literature review*, *Adv. Intell. Sys. Comput.*, 2019, 783, 405–414.
- [5] CAMILLIERI E., *Project success: Critical factors and behaviours*, Gower Publishing Company, 2011.

- [6] CARROLL C.F., *IT success and failure: The Standish Group CHAOS report success factors*, [Online] Available from: <http://www.cafe-encounter.net/p1183/it-success-and-failurethe-chaos-report-factors> (accessed 1 January 2014).
- [7] CHAN A.P.C., CHAN A.P.L., *Key performance indicators for measuring construction success*, *Benchmarking: An Int. J.*, 2004, 11 (2), 203–222.
- [8] CHARNES A., COOPER W.W., RHODES E., *Measuring the efficiency of decision making units*, *Eur. J. Oper. Res.*, 1978, 2, 429–444.
- [9] CHENG M.Y., TSAI H.C., SUDJONO E., *Evolutionary fuzzy hybrid neural network for dynamic project assessment in construction industry*, *Aut. Constr.*, 2012, 21, 46–51.
- [10] CHOW T., CAO D.B., *A survey study for critical success factors in agile software projects*, *J. Syst. Soft.*, 2008, 81, 961–971.
- [11] COOK W.D., ZHU J., *Rank order data in DEA: A general framework*, *Eur. J. Oper. Res.*, 2006, 174, 1021–1038.
- [12] COOPER W.W., SEIFORD L.M., TONE K., *Introduction to data envelopment analysis and its uses (with DEA-solver software and references)*, Springer, 2006.
- [13] DAVIS K., *Different stakeholder groups and their perceptions of project success*, *Int. J. Proj. Manage.*, 2014, 32 (2), 189–201.
- [14] DVOŘÁKOVÁ M., KLICNAROVÁ J., *On the differences between DEA and selected MCDM methods*, *International Scientific Conference INPROFORUM 2017*, 338–343.
- [15] DESPOTIS D., KUČHTA D., *Fuzzy weak link approach to the two stage DEA*, *RAIRO, Oper. Res.*, 2019, DOI: 10.1051/ro/2019093.
- [16] DEUTSCH M.S., *An exploratory analysis relating the software project management process to project success*, *IEEE Trans. Eng. Manage.*, 1991, 38 (4), 365–375.
- [17] EILAT H., GOLANY B., SHTUB A., *R&D project evaluation: An integrated DEA and balanced scorecard approach*, *Omega*, 2008, 36 (5), 895–912.
- [18] FAN D., *Analysis of critical success factors in IT project management*, *Proc. 2nd International Conference on Industrial and Information Systems*, Dalian, China, 2010, 487–490.
- [19] FRĄCZKOWSKI K., GŁADYSZ B., KUČHTA D., STANEK S., *Selection of IT projects to be implemented in an organisation to maximise their success probability*, *J. Dec. Syst.*, 2018, 27 (S1), 111–122.
- [20] FRĄCZKOWSKI K., KARWACKA D., *Examination of factors influencing the success or failure of IT projects*, [In:] C. Orłowski, Z. Kowalczyk, E. Szczerbicki (Eds.), *Knowledge and information technology management*, Pomorskie Wydawnictwo Naukowo-Techniczne, PWNT, Gdańsk 2008, 375–382.
- [21] GŁADYSZ B., KUČHTA D., *Multicriteria analysis of the success of research projects*, *Mult. Crit. Dec. Making*, 2017, 12, 22–35.
- [22] GOMES J., ROMÃO M., *Improving the success of IS/IT projects in healthcare: Benefits and project management approaches*, *Adv. Intel. Syst. Comp.*, 2016, 444, 547–556.
- [23] GREER M., *Handbook of human performance technology*, Jossey-Bass, Wiley, Chichester 1999.
- [24] IJPM, *International Journal of Project Management*, Special issue on *Project benefit management*, 2016, 34 (4).
- [25] KUČHTA D., SKOWRON D., *Classification of R&D projects and selection of R&D project management concept*, *R&D Management*, 2016, 46 (5), 831–841.
- [26] KUČHTA D., SKORUPKA D., DUCHACZEK A., KOWACKA M., *Modified, stakeholders perspective based DEA approach in IT and R&D project ranking*, *Proc. 18th International Conference on Enterprise Information Systems (ICEIS)*, Rome 2016, 2, 158–165.
- [27] LIM C.S., MOHAMED M.Z., *Criteria of project success*, *Int. J. Proj. Manage.*, 1999, 17 (4), 243–248.
- [28] MAGLYAS A., NIKULA U., SMOLANDER K., *Comparison of two models of success prediction in software development projects*, *Proc. 6th Central and Eastern European Software Engineering Conference (CEE-SECR)*, Moscow 2010, 43–57.

- [29] NAHOD M.M., VUKOMANOVIC M., RADUJKOVIC M., *The impact of ICB 3.0 competences on project management success*, *Procedia: Social and Behavioral Sciences*, 2012, 74, 244–254.
- [30] PINTO J.K., SLEVIN D.P., *Critical success factors in successful project implementation*, *IEEE Trans. Eng. Manage.*, 1988, 34 (1), 22–27.
- [31] QUELOPANA A., FLORES V., *A framework for IS project success analysis: A proposal*, *Proc. Iberian Conference on Information Systems and Technologies (CISTI)*, Cáceres, Spain, 2018, 1–5.
- [32] RAZ T., SHENHAR A.J., DVIR D., *Risk management, project success and technological uncertainty*, *R&D Manage.*, 2002, 32 (2), 101–109.
- [33] SERRADOR P., PINTO J.K., *Does Agile work? A quantitative analysis of agile project success*, *Int. J. Proj. Manage.*, 2015, 33 (5), 1040–1051.
- [34] SOWLATI T., PARADI J.C., SULD C., *Information systems project prioritization using data envelopment analysis*, *Math. Comp. Model.*, 2005, 41 (11–12), 1279–1298.
- [35] SHASHI K.N.R., NAI T.R.G., SUMA V., *SLI: A new metric to determine success of a software project*, *Proc. International Conference on Electronics and Communication Systems, ICECS 2014*, Coimbatore, India, arXiv:1407.8377.
- [36] STANKOVIC D., NIKOLIC D., DJORDJEVIC M., CAO D.B., *A survey study of critical success factors in agile software projects in former Yugoslavia IT companies*, *J. Syst. Soft.*, 2013, 86 (6), 1663–1678.
- [37] WATERIDGE J., *How can IS/IT projects be measured for success?*, *Int. J. Proj. Manage.*, 1998, 16 (1), 59–63.
- [38] WIJESINGHE R., SCHEEPERS H., MCLOUGHLI S., *Defining the optimal level of business benefits within IS/IT projects: Insights from benefit identification practices adopted in an IT service management (ITSM) project*, *Proc. 26th Australasian Conference on Information Systems (ACIS)*, 2015, Adelaide, Australia, arXiv:1606.03537.
- [39] WRAY B., MATHIEU R., *Evaluating the performance of open source software projects using data envelopment analysis*, *Information Management and Computer Security*, 2008, 16 (5), 449–462.
- [40] YOUSEF A.H., GAMAL A., WARDA A., MAHMOUD M., *Software projects success factors identification using data mining*, *Proc. International Conference on Computer Engineering and Systems*, 2006, 447–453.
- [41] YOURDON E., *Death march: The complete software developer's guide to surviving mission impossible projects*, Prentice Hall, 1997.
- [42] ZIJANG Y., PARADI J.C., *A DEA evaluation of software project efficiency*, *Proc. Industrial Engineering and Engineering Management Conference, Hong Kong 2009*, 1723–1727.
- [43] ZWIKAEEL O., CHIH Y.Y., MEREDITH J.R., *Project benefit management: Setting effective target benefits*, *Int. J. Proj. Manage.*, 2018, 36 (4), 650–658.

Received 8 December 2018
Accepted 11 November 2019