

*packaging, machine, design, genetic algorithm, structure*

*Taras VARANITSKYI, Bogdan PALCHEVSKYI\**

## **GENETIC-BASED APPROACH TO THE FUNCTIONAL-MODULAR STRUCTURE DESIGN OF PACKAGING MACHINES**

### **Abstract**

*The paper presents a method for decomposition of packaging machine structure in order to provide the designer with choices for feasible assemblies. The aim is at providing a systematic approach to explore a large number of decompositions prior to the detailed component design phase. The structure is transformed to a graph with equivalent topology by a genetic algorithm.*

### **1. INTRODUCTION**

Most of the packaging devices, especially packaging machines with modular structure are made by collecting various components of the simpler structure than the final product (Fig. 1). The synthesis of such a structure is the choice of what components should be added together to get a result in the construction with the necessary parameters. The method presented in this paper aims to systematize the process of structural synthesis of packaging machine with a main focus on its versatility, taking also into account productivity, cost, reliability, weight and overall performance. This approach aims to provide the designer feedback on possible designs of packaging machine before detailed design stage.

---

\* Lutsk National Technical University, 75 Lvivska str., 43018 Lutsk, tel.: +380 (332) 767395,  
e-mail: varanitskyi@i.ua, pac@tf.dtu.lutsk.ua

In this method, the design of packaging machine is obtained by optimization structure synthesis of a set of heterogeneous functional modules (FMs). This process includes three stages:

1. Creating a topological graph of the packing machine structure based on a set of elementary technological operations (ETO) and their corresponding functional modules;
2. Building the two-dimensional matrices for genetic coding of packing machine structure on the basis of topological graph;
3. Optimizing the formed matrix using a genetic algorithm with regard to the above criteria and consistency of the packing process.

The issue of synthesis of topological graph of the packing machine structure is considered as a discrete optimization problem that is solved by means of genetic algorithm.

## **2. CREATING A TOPOLOGICAL GRAPH STRUCTURE PACKING MACHINE**

Fig. 2 shows the course of forming the packing machine structure matrix. At the beginning the distinct parts of the packaging process are distinguished – the elementary technological operations (Fig. 2a). Each ETO is an action, which results in a new element of package to be formed or changing the shape, position or properties of the existing one.

Next, each ETO should be put in correspondence with a specific functional module (Fig. 2b). In view of technology or possible design of FM a separate ETO is not always performed apart so it is necessary to combine ETOs into sets. Each set describes a certain type of FM. For example, a set of ETO "to weld a longitudinal seam" and "move film sleeve" match to design of the roller mechanisms for longitudinal welding. Thus two types of functional modules that implement ETO sets are different, if these sets have at least one different ETO.

Obviously, the set may contain only one ETO. Sets of ETO significantly expand the number of FM designs that are used during the synthesis of structure packing machine.

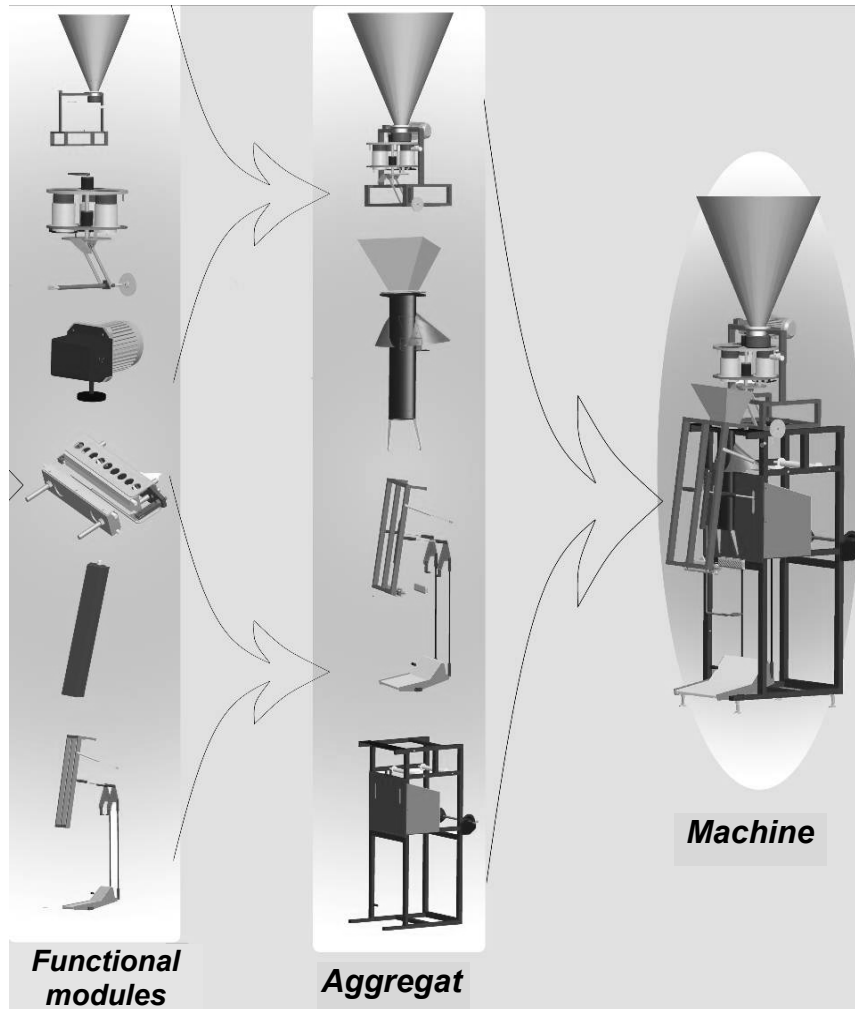
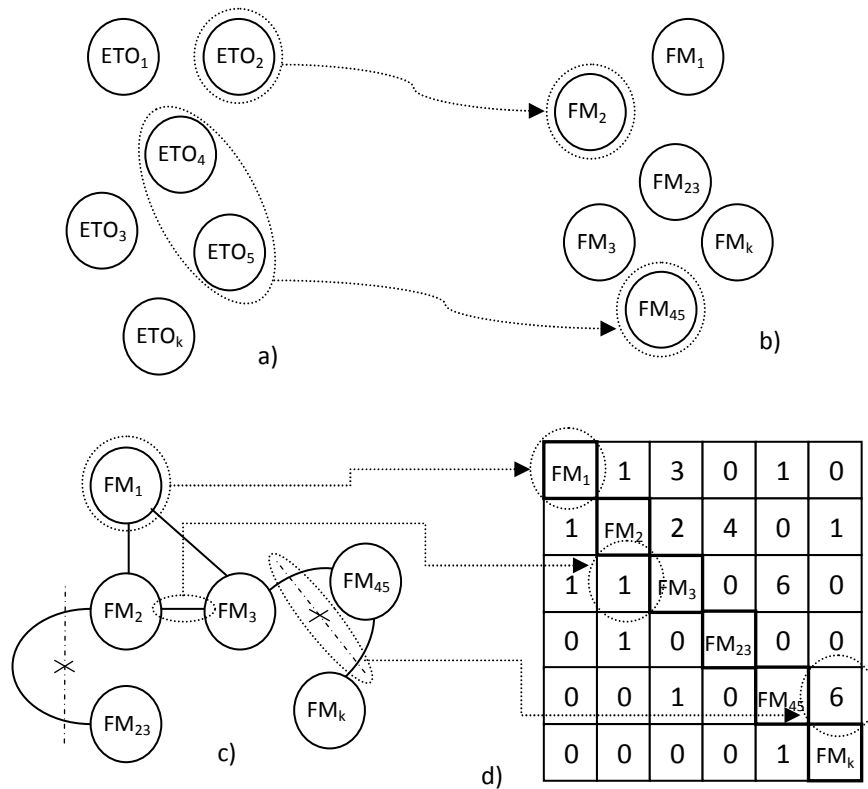

Fig. 1. Scheme of the packing machine decomposition [source: own study]

Each vertex in the graph is given a number. The numbering is carried out in accordance to a set of ETO, which the appropriate FM implements: first in the sequence of operations of a generalized process and then two digits – a combination of numbers of single ETO. Thus the obtained set of vertices of the structure topological graph includes the FM, presented by two types of sets: single and paired ETO.



**Fig. 2. Course of forming the packing machine structure matrix [source: own study]**

The next step is ordering the vertices: placing them in certain sequence and establishing connections between them (Fig. 2c). This process tends to generate a graph that describes the structure of the packaging machine and is performed in the following way:

1. A vertex that has the smallest number, usually 1, is selected from the set.
2. The value of degree is generated for each vertex. It is a natural number, limited to a certain value.
3. Steps 1 and 2 are repeated until the  $k$  vertices are collected. The maximum number of vertices in the graph  $k$  is limited by the number of structural elements in a family of products.

The generated graph should be checked on several grounds. The main purpose of this test is to set those options that represent actual allowable

structures of packing machine. Their separation will greatly accelerate the optimization process, reducing costs to process options that go beyond the space of feasible solutions.

Graph must be connected. Obviously, the machine cannot consist of a set of functional modules that are not linked, even if each of them separately can provide the relevant operations of package forming. Therefore a disconnected graph does not depict acceptable structure at all. In validation process all graphs the degree of at least one vertex is zero are discarded immediately, while others are checked by any known method (e.g. Kruskal's algorithm) for connectivity.

Graph must be simple, i.e. it should not contain loops or multiple bonds. The loop in this case means that the manufacture of the product may be stuck in one position in the machine. Multiple bond between the vertices of the graph leads to the loss of uniqueness in determining relative positions of FM in the machine. This problem is solved by creating a structure matrix: its completion is organized in a way that eliminates the appearance of loops and multiple bonds.

The FM describing the graph should implement all the ETO necessary for the formation of all structural elements of a product family in a given sequence. The longest path in the graph must include all ETO necessary for making at least one type of product. Otherwise the basic aim of the machine – producing the necessary range of products – is not provided.

As a result the topological graph of packing machine structure shows all its working positions and options the product routes in the machine.

### **3. BUILDING A MATRIX OF PACKING MACHINE STRUCTURE**

A matrix of packing machine structure is obtained by sequential cellpadding of the two-dimensional array. Each cell of the matrix is associated with the corresponding vertex of topological structure graph. The matrix size is  $k \times k$  elements. The adjacency matrix by which undirected graphs are usually describe is taken as a basis. However, a way its completion is modified the gain an opportunity to describe not only the interconnections between the vertices of the graph, but also the characteristics of arcs and the vertices themselves. A matrix of packing machine structure (Fig. 2d) can be divided into three parts, each comprising an encoded description of certain aspects of the structure of the packaging machine.

The first part is represented by cells that are below and to the left of the main diagonal of the matrix. The content of cells is based on the topological graph of structure and describes the links between the FMs in the machine. Filling of this

part is performed likewise cellpadding of classical adjacency matrix and fully describes the process of generating the graph. Since the topological graph of packing machine structure is a simple graph, the cells can only take values 0 or 1.

The second part of the matrix structure – is the cells that are above and to the right of the main diagonal. As usual adjacency matrix for an undirected graph is symmetric, it was decided to use these cells for expanding the characteristics of the graph. They show the actual links between FMs in a machine. Each cell in this part describes mutual position of a pair of FMs to which it relates. The value of the cell is a number that describes a one-way communication between the modules in the sequence of their connection. There may be six types of such links:

- Placement along the vertical axis
- Placement along the horizontal axis
- Placement along the inclined axis
- Placement in a circle with a vertical axis of rotation
- Placement in a circle with a horizontal axis of rotation
- Placement in a circle with oblique rotation axis

Therefore, each cell gains value from 1 to 6. So  $6^x$  connection methods between the neighbouring FMs can be specified.

The third part of the matrix – its main diagonal – describes the FM types included in the structure of the machine. Cells contain information about the design of FM and thus set of ETO it performs. The value of a cell consists of two digits. They point to the ETO implemented by a particular module. In case a set consists of one ETO, a zero is written in place of the second one. Filling of cells of the main diagonal is conducted according to the order of the process of packing. That is, cell  $a_{11}$  describes the FM, a set of ETO for which necessarily contains the first operation. Further cells respectively contain the entire set of ETO required for the formation of all structural elements from a given family of packages.

Thus, each cell of the main diagonal of the matrix of structure meets specific FM and its corresponding diagonal cells – additionally describe the location and characteristics of FM.

#### 4. MATHEMATICAL MODEL

Optimization synthesis of structure can be considered as a problem of creation of the graph. In such case the elements of the machine structure correspond to vertices, and the links between them – to edges that connect two or more vertices. Therefore, the whole structure can be represented as a graph  $G = (V, E)$ , where  $V$  – the set of vertices,  $E$  – set of edges. The problem of synthesis optimization then can be described as finding the optimal set  $P$  of nodes  $V$ , such that the objective function  $f(P)$  is maximized.

It should be noted that the number of vertices  $k$ , which form the best option is not defined in general. However, a set of characteristics  $F$  for each FM should be specified in order to get the opportunity to fully evaluate the various options of structure.

Thus, the optimization problem can be put as:

Given  $G$  a topological graph of structure,  $F$  a set of characteristics for each FM, and  $k$  the number of vertices. Find a vector  $x$ , which determines the optimal set of FM, the vector  $v$  – way to link FMs and vector  $y$  – description of each FM, subject to  $p(x,v,y)$  – the objective function that defines the quality of packing machine structure.

The objective function assesses the structure of the following criteria:

- Versatility – increased by introducing a FM, carrying out new functions into the structure of packing machine and depends on the combination method thereof;
- Productivity – rises by increasing the number of FMs;
- Reliability – reduced when FM, carrying out new features introduced into the structure of packing machine and depends on the combination method thereof.

To assess a packaging machine according to the criterion of universality, the total number of types and sizes of products, which the machine can produce is calculated primarily, and on this basis the coefficient of universality is determined. This value is determined by the structure of the machine and the set structural elements of products that specific FM produces. In general, the ratio of universality is the product of the coefficients of universality for serial and parallel connection of FMs. Thus arbitrarily complex TM is reduced to a chain of series-connected parts. Several FM, which operate in parallel or sequentially on the same level are considered as one group.

To evaluate the productivity of packaging machine the theoretical quantity of product it produces during a specified time is calculated. Raising the value of

this parameter can be achieved by increasing the number of FM as the slowest ETO, as well as throughout the whole packing machine.

Reliability of a packaging machine is estimated by the availability function. This value is calculated based on the known factors of availability for each FM and the method of connection thereof. Thus in case of serial connection, the reliability of a machine declines. This shortcoming can be partially removed by reserving FM on operations where there the failures are most often.

The following objective function is a result of combining the criteria:

$$f(x, v, y) = w_1 \cdot \left(1 - \left(\prod_{j=1}^{\alpha} (1 - K_{v_j}) \cdot \prod_{j=1}^{\beta} \frac{1}{\sum_{i=1}^q \left(\frac{1}{1 - K_{v_i}}\right)}\right)\right) + w_2 \cdot \left(\frac{1}{T_{\max}}\right) + w_3 \cdot \left(\frac{1}{1 + \sum_{i=1}^k \left(\frac{1}{K_{\Gamma_i}} - 1\right)}\right) \quad (1)$$

where:  $x=(x_i) - x_i$  is a variable that refers to the presence of the edge  $e_i$  in the  $x$ ,  
 $v=(v_i) - v_i$  is a variable that represents the weight coefficient of the edge  $e_i$  in the set  $x$ ,

$y=(y_i) - y_i$  is a variable that refers to the characteristics of the FM for the correspondent vertex,

$w_i$  – weights of partial criteria,

$\alpha$  and  $\beta$  – number of series-connected FM and parallel connected sets of FM respectively,

$K_{v_i}$  – actor universality of the  $i$ -th FM,

$q$  – number of parallel-connected FM,

$T_{\max}$  – the duration of the longest ETO,

$K_{\Gamma_i}$  – availability factor of  $i$ -th FM,

$k$  – number of FMs in the packaging machine.

## 5. OPTIMIZATION METHOD WITH USE OF GENETIC ALGORITHM

Synthesis of a graph is NP-complete problem even using simple linear relationships for calculating the value of criteria. As a result, all known algorithms that exactly solve the problem of graph synthesis, do it for the time that depends exponentially on the size of the graph. In our case objective function is nonlinear and since we cannot afford exponential computation, heuristic algorithms are found to be suitable. More specifically, a steady-state genetic algorithm (SSGA) has been used to solve the problem approximately, which goes through the following stages:



1. Randomly create a population  $P$  of  $n$  chromosomes (encoded representation of the parameters  $x$ ,  $v$  and  $y$ ), estimate the value of the objective function and keep the best chromosome. Create an empty subpopulation  $Q$ ;
2. Select two chromosomes  $c_i$  and  $c_j$  in  $P$  with a probability:

$$\Pr(c_i) = \frac{f_i}{\sum_{k=0}^n f_k} \quad (2)$$

where:  $f_i$  – value of the objective function for chromosome  $c_i$ ;

3. Crossover the chromosomes  $c_i$  and  $c_j$  and generate new chromosomes  $c'_i$  and  $c'_j$ ;
4. Mutate  $c'_i$  and  $c'_j$  with a certain low probability;
5. Evaluate the objective function for  $c'_i$  and  $c'_j$  and add them to  $Q$ . If  $Q$  contains less than  $m$  chromosomes move to step 2;
6. Replace  $m$  chromosomes in  $P$  with the ones in  $Q$  and empty  $Q$ . Update the best chromosome and increment the generation counter. If the generation counter has reached a pre-specified number, terminate the process and return the best chromosome. Otherwise go to 2.

The main advantage of SSGA is empirically set prevention of premature convergence and optimal results obtained in fewer computations.

Each version of the packaging machine is encoded in a matrix structure, which is also its chromosome. Values of genes are identical and describe the same characteristics as the corresponding matrix cell.

It should be noted that the information is the first part of the chromosome refers to the vector  $x$ , the second – to the vector  $v$ , and – the third to vector  $y$  in a mathematical model. Also is necessary to stress that not every chromosome describes the "true" structure of packing machine. Eliminating some edges may not lead to destruction of the structure, so each option should be checked whether it meets the unconnected graph. Obviously, the ideal case is all the  $k$ -connected vertices.

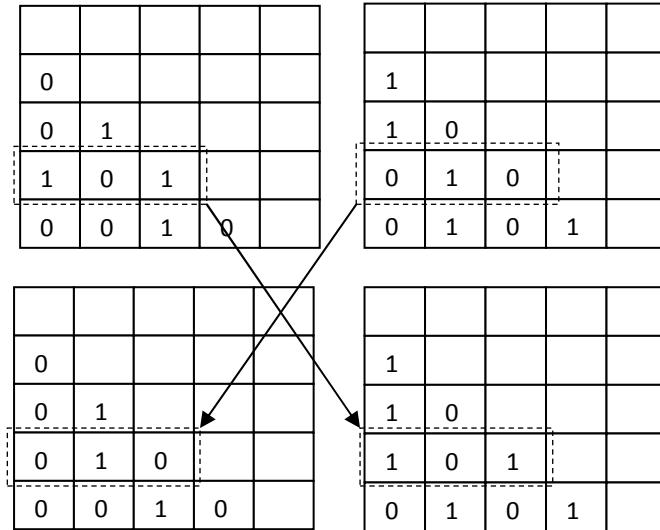

**Fig. 3. Cross-over of two chromosomes [source: own study]**

Since chromosomes, describing the structure of packaging machine contain three types of information there is a need to configure crossing-over and mutation operators. Cross-over operator influences on each part of chromosome separately. It is performed in two steps where the first third mates with the first third, and third – with the third part of the chromosome. Such crossing takes place in lines (Fig. 3), the line number being also generated randomly. Crossover is not performed for the main diagonal. Thus when deploying a matrix structure in line, we have actually multipoint crossover.

The mutation operator differs from the typical one by the higher probability of the second part of the chromosome.

## 6. EXAMPLE OF PRACTICAL IMPLEMENTATION

For example, consider the process synthesis and optimization of the structure of a packaging machine for loose products. By the condition the machine must produce a family of three types of packages: three-seam "cushion"-type package, package with a flat bottom and a bent top package. ETO set for this family of packages will be as follows:

1. Bend the film into sleeve
2. Weld the lower cross seam
3. Weld the top cross seam
4. Weld the longitudinal seam
5. Bend the bottom of the package
6. Fold the top of package
7. Cut the finished package
8. Pull a film sleeve on a step

15 sets of ETO and the same number of FM structures can be put in correspondence with the above set, namely:

- single FM1, ... FM8
- double FM23, FM25, FM27, FM36, FM37, FM48, FM56

The first generation of the genetic algorithm generates the following matrix of packing machine structure size 8x8:

01	0	2	0	0	0	0	0
0	25	0	1	0	3	0	0
1	0	06	0	0	5	0	0
0	1	0	36	2	0	0	0
0	0	0	1	56	0	2	4
0	1	1	0	0	04	1	0
0	0	0	0	1	1	08	0
0	0	0	0	1	0	0	37

Fig. 4. This also will be the rough location of FMs in the machine.

During the genetic algorithm process each part of the chromosome undergoes the following processes:

- as a result of mutations in the main diagonal the required set of ETO is determined and composition of FMs in the machine is optimized. This may also change the universality – the presence of vertices with identical ETO in sets can create the

As can be seen from the genetic code, this chromosome does not represent an acceptable construction of packaging machine because the necessary sequence of package producing process is not provided. The structure graph of the FM set has the form shown in

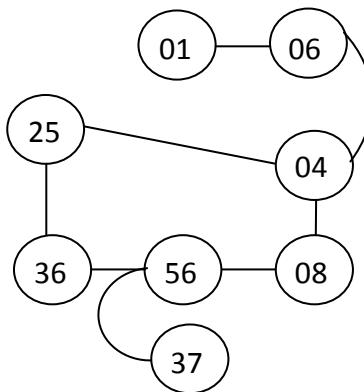

Fig. 4. The structure topological graph, formed at the first generation [source: own study]

alternative ways of passing the product through the machine without its readjustment and form routes that lead to the creation of a new product type;

- genetic changes in the first part of the chromosome lead to the establishment of the required order of ETO. Basically, this process occurs due to crossing-over, mutation only accelerates finding the final result;
- the third part of the chromosome is responsible for setting such geometric relationships between FM, in which the machine design is not too cumbersome and provides a logical and efficient product passing through all positions.

Fig. 5 shows two couples of "matrix structure – topological graph", illustrating the possible intermediate stages of optimization synthesis of packing machine structure.

The first pair (Fig. 5a) represents already established set of ETO. Links between modules do not describe the acceptable design of packaging machine yet. The lack of connections between some FM is evident so this structure still needs refinement so that permissible design of packaging machine could be put in correspondence to it.

The second pair (Fig. 5b) shows the case where the manner and types of connections between vertices of the graph can represent realistically possible machine design. However, the main diagonal of the matrix is filled chaotically: an unreasonable duplication of some ETO and the absence of others occurs. As a result of mutations, the set of encoded ETO should be reduced to the "rules" to achieve the acceptable solution of the problem.

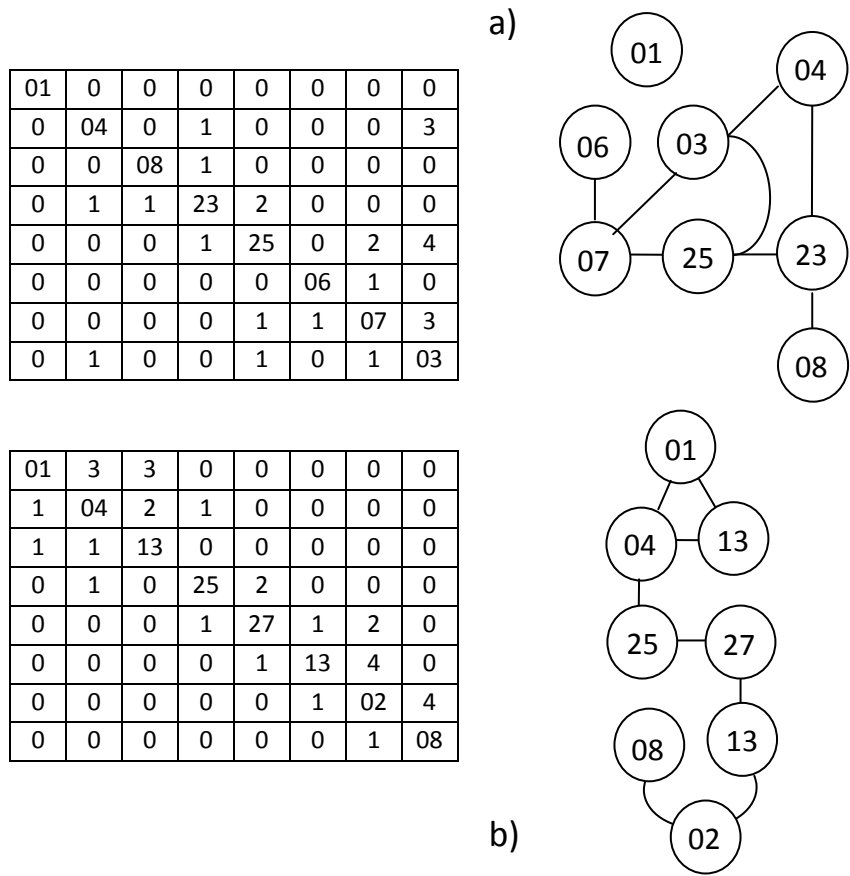
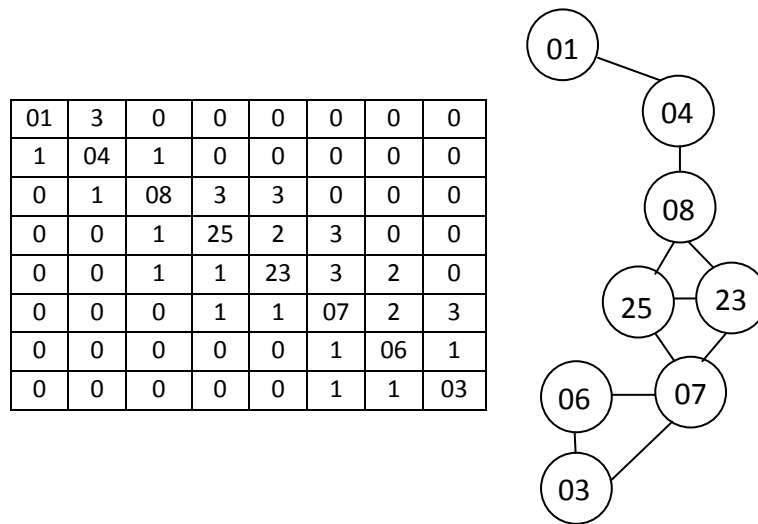

**Fig. 5. Interim results of packing machine structure optimization synthesis using GA [source: own study]**

Comparison of the interim results for multiple chromosomes on intermediate generation leads to identify trends that demonstrate how a matrix of packing machine structure mutates when approaching the optimal solution. The first trend is the location of FM numbers in ascending order along the main diagonal of the matrix. The second trend is reflected in the "clustering" of nonzero values of cells on both sides of the main diagonal.

Of course, in both cases, there may be some deviation, but the preservation of classical logic and sequence of ETO for packing loose products finds confirmation in the application of genetic algorithm.

Finally, Fig. 6 shows a chromosome of a possible structure of packing machine, and its topological structure graph.



**Fig. 6. Feasible final structure of packing machine obtained with GA**  
[source: own study]

The process of packing in this case will take place in the following sequence:

- film rolled up in the sleeve moves at an angle to the longitudinal seaming mechanism,
- seamed sleeve moves to pulling mechanism that is placed vertically under the longitudinal seaming mechanism,
- before filling the blank with the product one of two mechanisms of cross seaming triggers: mesh sponge, forming both the upper seam of next package and the bottom of the previous one or the mechanism which bends the bottom of the package and welds only the bottom seam,
- next the package moves vertically downward for cutting,
- when secondary mechanism of cross seaming triggered, the filled and cut package passed horizontally to the mechanism of folding the top of package, and then – straight down – the upper cross seam is formed,
- if the folding the top of package is not necessary – the blank is immediately transmitted along an inclined trajectory to the transverse seaming mechanism.

## REFERENCES

- [1] F. ARKIN YETIS, KAZUHIRO SAITOU: *Decomposition-Based Assembly Synthesis Based On Structural Considerations*. Proceedings of DETC'00 ASME 2000 Design Engineering Technical Conferences and Computers and Information in Engineering Conference, 2000.
- [2] PALCHEVSKYI B., VARANITSKYI T.: *Analysys Of Variability Of The Family Of Packages And The Versatile Packaging Machine Design*. Applied Computer Science Vol. 8, №2, 2012, p.22-33.
- [3] PALCHEVSKYI B.: *Avtomatyzacija technologichnykh protsesiv (vygotovlenia i pakuvannia vyrobiv)* (in Ukrainian). Svit, Lviv, 2007.