

Kamil KURPIEL

Politechnika Warszawska, Wydział Budownictwa,

Mechaniki i Petrochemii w Płocku

Wydział Budownictwa, Mechaniki i Petrochemii

kamil@kurpiel.com.pl

THE IMPACT OF THE STRUCTURE OF THE SAMPLER FOR SAMPLE COLLECTION ON THE REPRESENTATIVENESS OF LPG SAMPLES

Key words

Gas sampler, sampler structure, LPG sample, representativeness of the sample, LPG quality.

Abstract

This research paper describes the results of a research project on how the structure of the sampler for assembling and storage of LPG samples influences the representativeness of samples under study. The representativeness of the sample was compared to the quality parameters of the study sample for the given part of the cargo from which it was taken. This article refers to the traditional solution of the non-dismountable sampler and to the dismountable sampler applied as a new solution.

In the dismountable sampler, apart from the structure, material and surface treatment of the inner part of the cylinder that reacts with gas fuel have been changed. Based on the conducted research and analysis, the impact of the changed structure on the quality parameters of the LPG fuel and its representativeness in reference to the part of the cargo from which it had been

taken can be assessed. The researched solution on the dismantled sampler was patented (Patent no. 214183), implemented, and applied in practice.

Introduction

The collection and storage of the representative sample of a part of cargo is key to the assessment of its quality parameters. The proper collection of a representative sample is of vital importance due to the increased quality requirements of the LPG fuel, the development of the analytical techniques, and the growing experience of the research personnel. At present, the process of collection and preparation of the sample is the most crucial one, because it influences the correctness of the parameter assessments in reference to the part of the cargo. It is often of significant financial importance to the parties involved in the LPG fuel business, and it is also relevant from the end-client perspective.

Poland is one of the countries with the largest LPG consumption, and its share in the fuel market grows year to year. Along with the fuel popularity growth, the industry related to this branch of business has developed. Poland has become the global leader of solutions in this field. Due to the growing importance of the fuel and the constantly increasing LPG quality requirements, analytical problems arise, which until recently have been of minor importance. The issue of the proper storage of the analytical sample from part of the cargo has not been analysed so far. The available literature does not touch upon this topic in the aspect of the possible analytical problems and does not go beyond the framework of the existing PN-EN ISO 4257 norm on LPG sample collection. Taking into account the growing quality of the requirements towards fuel, the development of technology of the measurement equipment, knowledge growth, the growing experience of the research staff, and the practical problems that occur during the analytical determination, the solution that eliminates the problem has been developed. This solution will enable the storage of a highly representative sample of part of the cargo and its proper assessment. Due to the pertinence of the topic and the strong conviction that the already existing solutions are valid, no successful attempts to test new solutions or their impact on the whole analytical process have been made so far. Ever since the norm PN-EN ISO 4257, which describes the process of collecting gas samples, it has been applied, and samplers have been used that could not be thoroughly cleaned. The norm provides a means of cleaning with the use of the method of multiple rinsing with the collected gas. Additionally, the cleaning of the probes with the solvents, which were to guarantee the proper preparation of a sampler to sample collection, has been implemented. In the carried out research, the results of the particular measurements of the LPG gas quality parameters were compared with the use of two different technical solutions for samplers and the way of cleaning

them. In the course of the research, an attempt was made to show the impact of the structure and the preparation of the sampler for sample collection and its cleanness on the representativeness of the quality assessment. The research on the quality parameters assessment of the collected gases and the macroscopic research on the inner surface of the samples were undertaken. The observation was made on the creation of the layer of impurities in the non-dismountable samplers. The composition of the layer was examined and its probable influence on changing the LPG gas quality parameters defined. The research proved a considerable impact of the sampler preparation and its cleanness on quality parameters such as corrosive action on copper and total sulphur content. The dismountable sampler solution applied in practice will open the door to a thorough LPG fuel analysis and the repeatability of results at all stages of fuel trading.

Solutions that are used nowadays and their results, i.e. differences in the analysis of the same gas often trigger penalties on entrepreneurs involved in LPG trading that are wrongly imposed. The unit that verifies quality is the Inspectorate of the Trade Inspection, which, by the application of law through the bodies such as the Office of Competition and Consumer Protection and Energy Regulatory Office, is used to prove the instance of noncompliance with quality requirements imposes penalties. Penalties of up to 1 million PLN as well as imprisonment of up to 3 years are used. In practice, this solution will open the door to precise assessment of the quality and the classification of fuel to protect both the end client and the business of specific entrepreneurs, stimulating the further growth of the industry at the same time.

1. Research on the surface of the materials used in samplers

Destructive and non-destructive tests of different types of samplers were carried out in order to obtain information on the impact of the structure of the sampler and its inner surface on the processes inside the sampler and the representativeness of the sample. The standard non-dismountable sampler made of chromium nickel steel type 316L was compared with a dismountable sampler made of chromium nickel steel type 316Ti.

Additionally, in the case of the dismountable sampler, to prepare the inner surface of the cylinder, the process of mechanical polishing with chemical etching and electropolishing was applied. The surface was further oxide passivated. Both samplers and their sectional view are illustrated in Figs. 1 and 2.

As far as the dismountable sampler is concerned, as a new solution, the application of the process of chemical etching and electropolishing was used to reduce the microporosity of the surface, which effectively diminishes the risk of dirt, sediment, or chemical compounds building up and enhances the susceptibility to surface cleaning.

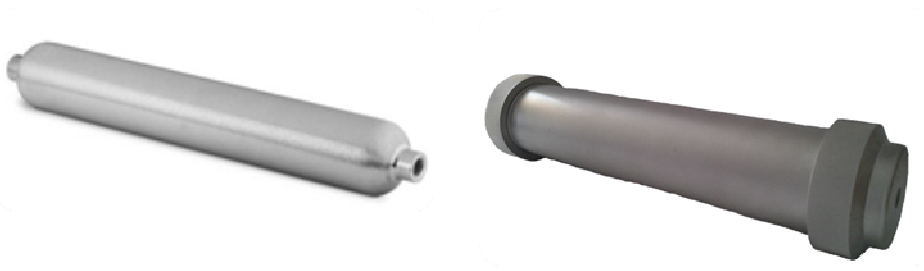

Fig. 1. Traditional non-dismountable sampler (left) and dismountable sampler (right)

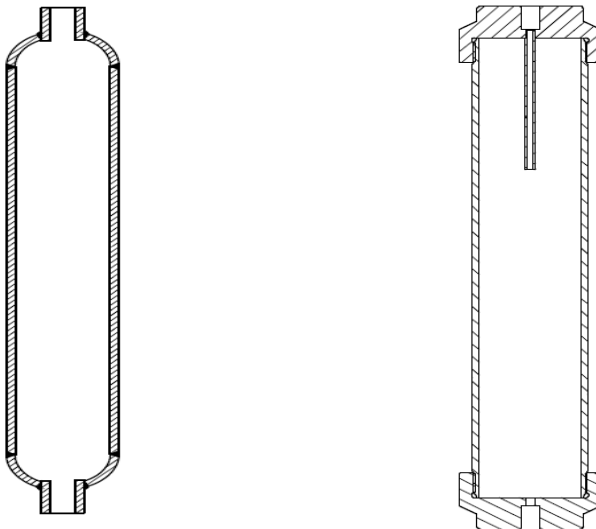

Fig. 2. Sectional view of traditional non-dismountable sampler (left) and dismountable sampler (right)

The applied processes uncover a uniform, metallurgically clean metal surface, and close micropores, which prevent chemical impurities from penetrating and eliminate build up. Electropolishing enhances the subsequent passivation of the surface. The passive layer is to protect the surface of the cylinder from the build-up of compounds that, if accumulated, may distort results of the samples in case the sampler is used over a longer period of time.

Non-destructive microscopic testing of the inner surface of the sampler has shown the surface structure of both types of solutions. The surface of the non-dismountable sampler (Fig. 3), where no additional mechanical processing was applied, is very uneven, with distinct scratches with sharp edges created during mechanical processing. On such a surface, impurities can easily build up and

accumulate, and this may have an impact on the later results of gas analysis. The roughness of the surface makes it difficult to thoroughly clean the impurities, which directly influences the possibility of a secondary reaction in the cylinder and a change in the quality parameters of the samples. In the case a dismantlable sampler (Fig. 4) where additional treatment processes have been applied, the surface is smooth, pores closed, and the structure is homogenous. Surface prepared in this manner makes it difficult if not impossible for sediments and impurities to stick to the surface, thus enhancing the representativeness of collected samples. The lack of the possibility to build up impurities affects the cleaning process which becomes easier and more thorough, and which, in turn, ensures better cleanness of the sampler and the representativeness of obtained analysis.

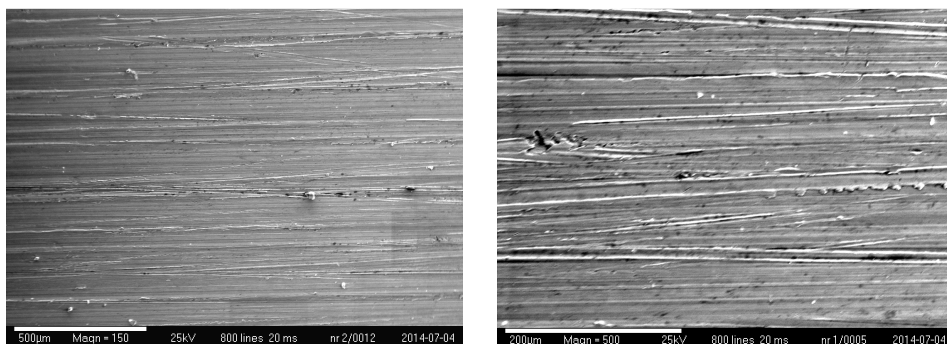

Fig. 3. The inner surface of the non-dismountable sampler as seen under microscope 150 (left) and 500 (right)

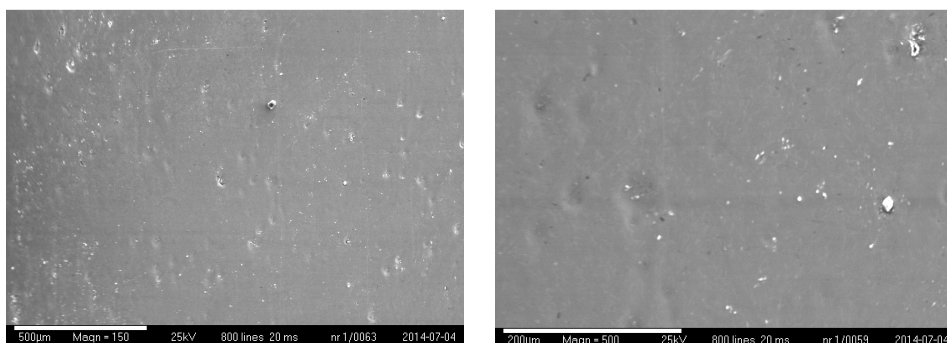

Fig. 4. The inner surface of the dismantlable sampler as seen under microscope 150 (left) and 500 (right)

Destructive testing has also been carried out that revealed the characteristics of both types of the sampler structures. Each sampler was used to collect 250 LPG gas samples. The samplers were cleaned according to the PN

ISO 4257 norm prior to each sample collection. Having performed a series of samples, the dismountable sampler was taken to pieces to observe the inner part of the cylinder, which is illustrated on Fig. 5.



Fig. 5. Traditional non-dismountable sampler

Having performed a series of samples, the non-dismountable sampler was cut open along its axis to observe the inner part of the cylinder, which is illustrated on Fig. 6. For comparison purposes, a sectional view of a clean, unused sampler was placed to the right.



Fig. 6. Traditional non-dismountable sampler after a series of sample collection [left] and clean non-dismountable sampler [right]

In the case of the non-dismountable sampler, dark brown sediment from the inside was removed and sent for basic element analysis. The analysis tested positive for elements such as Na, K, Mg, Ca, Al, V, Ni, Co, Mn, Fe, and S. The least welcome element on the list is sulphur. Its content in the tested sediment was 0.72 % m/m. Sulphur in sediment is to be found mainly in the form of inorganic compounds that, in specific conditions, may create secondary reactions with hydrogen sulphide and sulphur emission.

2. Quality research on the selected parameters of the LPG gases

Using both types of samplers in an analogous collection environment as well as the analysis of gas samples, quality analysis of the LPG gases were conducted. At different time intervals over the period of 3 years, 2113 analysis were undertaken according to the norms as set out in the table below:

Parameter	Research method	Measurement deviation range for a non-dismountable sampler [%]	Measurement deviation range for a dismountable sampler [%]
Hydrocarbon composition (% m/m)	PN ISO 7941	0.6 – 3.0	0.8 – 3.3
Motor octane number	PN EN 589 A	0.8 – 3.3	0.6 – 3.0
Relative vapour pressure at temp. 40°C (kPa)	PN EN 8973	0.8 – 3.3	0.6 – 3.0
Temp. at which relative vapour pressure is not lower than 150 kPa(°C)	PN EN 589 C/ PN EN 8973	0.8 – 3.3	0.6 – 3.0
Water content	PN EN 589	0	0
Smell	PN EN 589 A	0	0
Density at temp. 15°C	PN EN 8973	0.8 – 3.3	0.6 – 3.0
Hydrogen sulphide	PN EN 8819	0	0
Total sulphur content (mg/kg) For new samples (30 measurements)	ASTM D6667	0.3 – 2.3	0.2 – 1.1
Total sulphur content (mg/kg) for samplers after approx. 200 samplings (43 samples)	ASTM D6667	1.5 – 11.1	0.2 – 1.0
Corrosive action on copper (1h/40°C) (250 samples)	PN EN ISO 6251	8% 8 samples noncompliant in class 14 in subclass	0,4% 1 sample noncompliant in subclass
Corrosive action on copper (1h/40°C) (no water) (250 samples)	PN EN ISO 6251	7.2 % 7 samples noncompliant in class 11 in subclass	0

The table represents research methods and results. The results are stated as an absolute value. For parameters such as corrosive action on copper and the total sulphur content, research result deviation for some of the samples were of crucial importance to the correct quality classification of fuel. Part of the analysis with a traditional sampler solution has shown the lack of quality conformance of the fuel under analysis to the requirements as set forth in the ordinance of the Minister of Economy of 12 December 2011 on LPG fuel.

Discussion and the summary of the research results

The long-term research results presented in the table and carried out on authentic fuel samples indicate the differences in the determined values of the standardized parameters of the same gas samples, which depend on the means of their collection. In practice, such differences in the values of the parameters that are under determination occur in research carried out by different laboratories. The controversies around the diverse analysis results of the same material may lead to far-reaching consequences, both financial and legal. This is why all interested parties should strive to objectivize the obtained measurement results. It applies to producers, importers, carriers, supervisory and standardization bodies, and especially quality control laboratories.

Assuming, and as supported by exploitative data, that the means of sample collection may affect (and often do affect) the obtained results of the determination of physiochemical properties of the liquefied hydrocarbon gases, prototype pressure samplers for LPG sample collection have been designed and built. The structure and the way the device surface is prepared should help avoid the accumulation of micro impurities that LPG contains. Deposits accumulated on the surface of the traditional samplers may distort measurement results of the particular LPG parameters.

The results shown in the table on the comparative exploitative research on two LPG samplers, the traditional one and a new construction, point to the advantages of the new solution. The results of total sulphur content determination and the corrosive action on copper are of special importance to the objective LPG quality assessment. These parameters are simultaneously the most frequent cause for going beyond the LPG fuel quality norm. Data on the results of the fuel quality control gathered and published by the Office of Competition and Consumer Protection (UOKiK) support the above statement. Despite the fact that LPG fuel comparatively demonstrates the lowest percent of quality deviations among motor fuels, the research results presented in this article suggest that not all of them are derived from credible measurements. Failure to keep the quality norms leads to penalties and legal consequences, including the loss of the motor fuel licence.

Significantly smaller deviations in measurement results of the sulphur content, and especially the corrosive action on copper, require very serious consideration of the proposal for structure and exploitation of the LPG sampler. A patent as the legal protection umbrella of the invention adds value to this new solution.

The obtained results enable the statement that the structure of the dismountable sampler with the inner cylinder surface treatment affects the representativeness of the collected and analysed LPG gas samples. It is of crucial importance for gas quality parameters such as the corrosive action on copper and total sulphur content. The impurities that may exist in LPG, originating from the refinery and petrochemical processes (hydrogen nitride, water, sulphur, methanol, higher hydrocarbons, dirt) as well as the distribution system, are the cause of secondary reactions. The results of such secondary reactions negatively influence the LPG quality. Their occurrence is triggered by even minimum level of impurities that may gather inside of the sampler.

The possibility to dismantle and thoroughly clean the sampler prior to sample collection enhances the certainty of obtaining highly representative samples and credible test results.

References

1. PN-EN ISO 4257, 2004
2. PN-EN 589, 2012
3. The ordinance of the Minister of Economy of 12 December 2011 on LPG fuel changing the ordinance on the liquefied gas (LPG) quality requirements.

Wpływ konstrukcji próbnika do poboru próbek LPG na reprezentatywność próbek LPG

Słowa kluczowe

Próbnik gazowy, konstrukcja próbnika, próbka LPG, reprezentatywność próbki, jakość LPG.

Streszczenie

W opracowaniu opisano wyniki prac badawczych dotyczących wpływu konstrukcji próbnika do poboru i przechowywania próbek LPG na reprezentatywność badanych próbek. Reprezentatywność próbki odniesiono do parametrów jakościowych badanej próbki dla partii towaru, z której została pobrana. Opracowanie odnosi się do rozwiązania tradycyjnego próbnika nierozbieralnego oraz zastosowanego jako nowe rozwiązanie próbnika rozbieralnego.

W próbniku rozbieralnym oprócz zmienionej konstrukcji wprowadzono zmianę materiałową oraz zmieniono obróbkę powierzchniową wewnętrznej części cylindra mającej kontakt z paliwem gazowym. Na podstawie przeprowadzonych badań i analiz można określić wpływ zmienionej konstrukcji na parametry jakościowe paliwa LPG oraz jego reprezentatywność w odniesieniu do partii towaru, z której próbka była pobrana. Opracowane rozwiązanie próbnika rozbieralnego zostało opatentowane (Nr patentu P.214183), wdrożone do produkcji i jest stosowane w praktyce.