

The Influence of Anchor Devices on the Performance of Retractable Type Fall Arresters Protecting Against Falls From a Height

Krzysztof Baszczyński

**Department of Personal Protective Equipment, Central Institute for Labour Protection
– National Research Institute, Łódź, Poland**

Retractable type fall arresters are part of the equipment used for protecting people against falls from a height. They are an intermediate part between full body harness worn by a man and the structural anchor at the worksite. The most important task of retractable type fall arresters is to arrest people's falls and to reduce their harmful consequences. Information received from users as well as laboratories testing protective equipment indicates that the performance of such equipment is incorrect under specific conditions. The paper is concerned with an analysis of the conditions in which retractable type fall arresters demonstrate intermittent performance and with an explanation of that phenomenon. The results of tests investigating anchor devices and the performance of retractable type fall arresters are presented. External and internal factors contributing to intermittent performance have been determined and guidelines for safer use of these devices have been developed.

personal protective equipment against falls from a height retractable type fall arresters
anchor devices test methods dynamic performance test

1. INTRODUCTION

Retractable type fall arresters compliant with the requirements of Standard No. EN 360:2005 [1] belong to protective equipment used in systems designed for protecting people against falls from a height. These devices, described by Sulowski [2, 3], Paureau [4] and in standards [5, 6], currently constitute one of the most effective types of protective equipment arresting falls from a height and reducing their harmful consequences. Their construction and working mechanism allow their use at worksites located at a height, where the worker must move in the vertical direction in order to perform some specific operations. The

most significant advantages, considering the user's safety, include

- reduction of the free fall distance to a minimum;
- reduction, to safe values, of the fall arresting force (acting on the human body through the full body harness);
- ensurance of an appropriate position of the user's body (vertical with legs down) during fall arrest;
- continuous protection of the user as he moves around at the worksite.

Correct performance of retractable type fall arresters during fall arrest has a crucial impact on the user's health and even life. That is why, retractable type fall arresters are subject to mandatory

assessment of their compliance with the essential requirements of Directive 89/686/EEC [7] and production quality inspections by notified bodies.

Because of the importance of this problem, the Central Institute for Labour Protection – National Research Institute has been conducting both research on [8, 9] and type tests (to assess their compliance with the requirements of Directive 89/686/EEC [7]) of retractable type fall arresters.

Results of these studies and information from users and from laboratories testing protective equipment indicated that the performance of such equipment was incorrect under specific conditions. This irregularity manifested itself in no permanent blocking of the retractable lanyard during fall arrest and intermittent performance. Such performance involved temporary blocking, and then unblocking of the retractable lanyard, as a result of which the subject's fall was not arrested but only slowed down. Preliminary analysis of this problem demonstrated that the effect of such performance of retractable type fall arresters (blocking and unblocking) during fall arrest could be considerably hazardous for a person. This hazard was associated, first of all, with significant elongation of the fall arrest distance, and it became especially important if there were any dangerous objects below the feet of the user, such as construction elements of the worksite.

As it followed from preliminary observations, intermittent performance of some retractable type fall arresters was associated with their construction, the rigidity of the anchor device, on which the fall arrester was installed, and the mass of the object whose fall was being arrested.

This paper is concerned with explaining the intermittent performance of retractable type fall arresters and the causes and conditions of its occurrence. The presented information makes it possible to eliminate the risk of incorrect performance of these devices by appropriate selection of protective equipment and anchorage methods.

2. INSTALLATION OF RETRACTABLE TYPE FALL ARRESTERS ON THE WORKSITE

The prerequisite for proper function of retractable type fall arresters is that they have to be connected with the construction of the worksite. Such connection is accomplished by means of an anchor device, which consists of

- clamping elements such as connector, formed wire clamp, anchor line; and
- fragments of worksite construction, e.g., structural beam, structural anchor, etc.

The requirements that anchor devices for retractable type fall arresters should meet [1, 10] concern three essential aspects:

- resistance to static and dynamic loads guaranteeing no break of the anchor device during fall arrest;
- shape, dimensions, etc., guaranteeing reliable connection of retractable type fall arresters with the anchor device;
- location, perpendicular to the user's head, which ensures minimization of the fall distance and elimination of a pendulum motion of the user's body during fall arrest.

It is possible to meet those requirements by means of various construction solutions. A built-in rigid anchor device located on the concrete ceiling of the worksite is an example of an ideal solution (Figure 1).

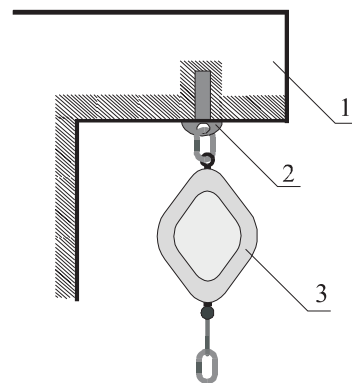

Figure 1. An example of a rigid anchor device.
Notes. 1—part of worksite, 2—structural anchor, 3—retractable type fall arrester.

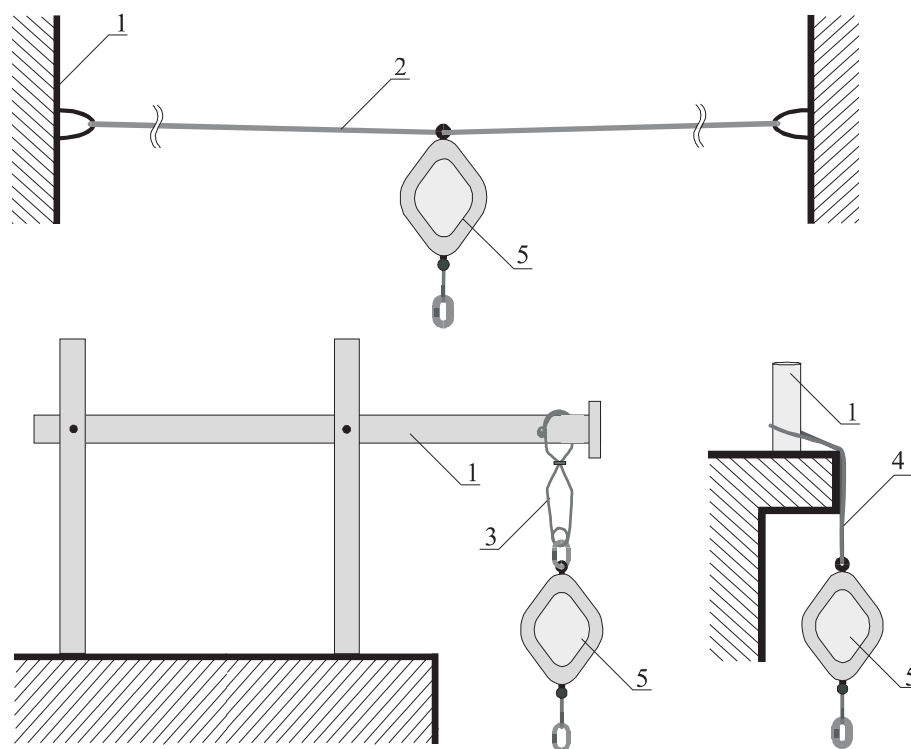

Figure 2. Examples of flexible anchor devices. Notes. 1—rigid part of worksite, 2—horizontal flexible anchor line, 3—formed wire clamp, 4—vertical flexible anchor line, 5—retractable type fall arrester

Such a solution is characterized by negligibly small deformations during fall arrest. In practice, due to specific layout of the worksites and type of work to be done, it is often necessary to apply more complex solutions of anchor devices. Examples are shown in Figure 2.

Mechanical parameters of such anchor devices are significantly different from the parameters of a rigid anchor device, and, as demonstrated by the aforementioned observations, they may contribute to an intermittent performance of retractable type fall arresters.

3. PROPERTIES OF ANCHOR DEVICES

To determine the properties of an anchor device–rigid mass assembly, which could influence the performance of a retractable type fall arrester during fall arrest, two essential parameters were selected on the basis of available literature [11, 12, 13]:

- f_R damped vibration frequency,

- δ_T logarithmic decrement of vibration damping defined as

$$\delta_T = \ln \frac{a_n}{a_{n+2}} \quad (1)$$

where a_n and a_{n+2} are maximum values of the amplitude, differing by a period.

These parameters characterize the vibrations of the anchor device–rigid mass assembly during fall arrest. In order to determine the value of these parameters for selected anchor device types, a test stand was used (Figure 3).

A rigid construction (3), compliant with the requirements of Standard No. EN 364:1992 [14] with respect to resonance frequency and deformation caused by static load, was an essential element of the stand. The tested anchor devices (8) were mounted on this construction in a way dependent on their structure. The anchor device (8) together with the test rigid mass (7) $m = 100$ kg constituted a vibratory system. Vibrations of the system were recorded with a type 7265A accelerometer (Endevco, USA) (4), coupled with type 106 amplifier by the same manufacturer (5)

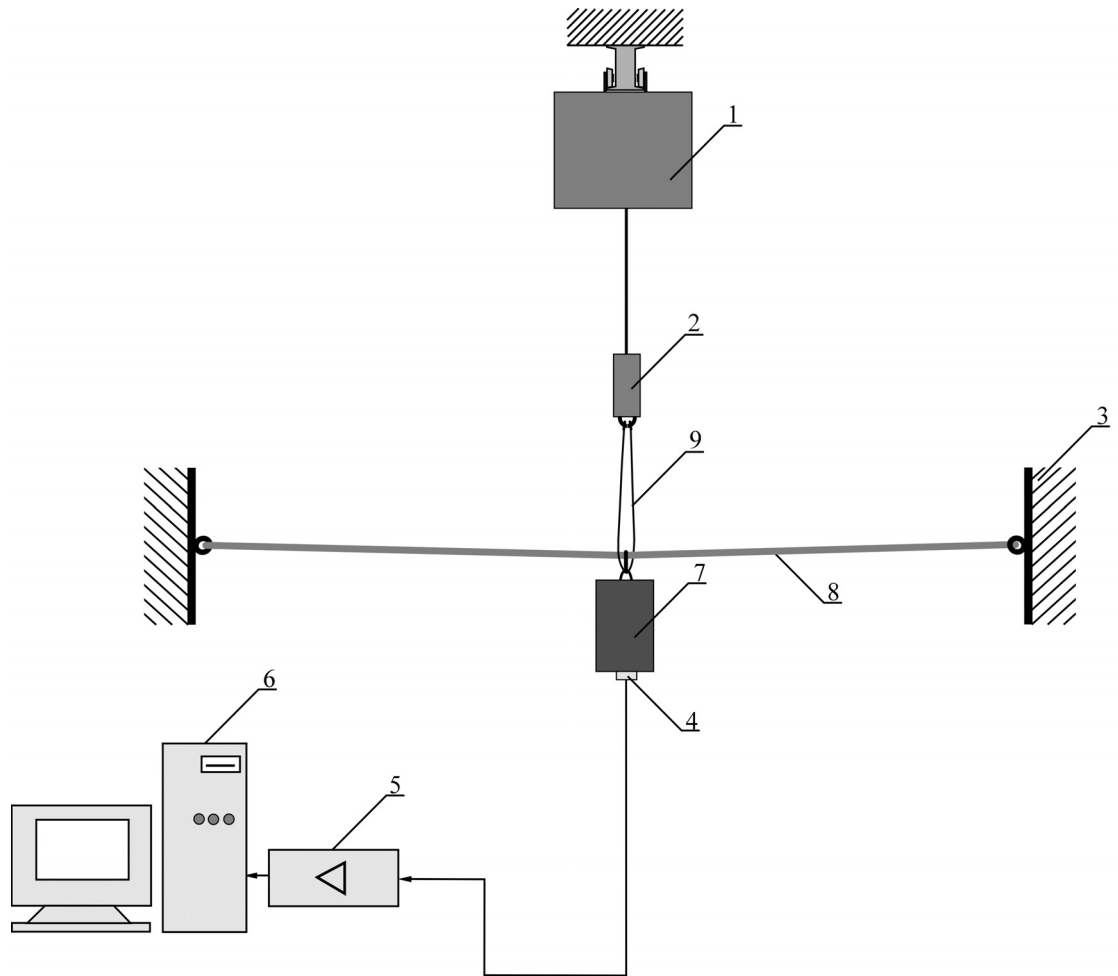

Figure 3. Test equipment and test method for flexible anchor devices. Notes. 1—power winch for lifting and lowering test mass, 2—quick release device, 3—rigid construction, 4—type 7265A accelerometer (Endevco, USA), 5—low-pass filter with type 106 amplifier (Endevco, USA), 6—personal computer with type DAP-1200e measuring card (Datalog, Germany), 7—test mass, 8—anchor device, 9—flexible connector.

TABLE 1. Tested Anchor Devices

Type	Material	Code	Construction
Vertical anchor line	steel wire rope, diameter: 8 mm	v1	total length of anchor line: 2 m; terminations equipped with 10-cm long loops
	woven polyamide rope, diameter: 12 mm	v2	
	three-strand polyamide rope, diameter: 12 mm	v3	
	woven polyester rope, diameter: 12 mm	v4	
	three-strand polyester rope, diameter: 16 mm	v5	
	Kevlar rope, diameter: 12 mm	v6	
	single mountaineering rope, diameter: 11 mm	v7	
Horizontal anchor line	steel wire rope, diameter: 8 mm	h1	total length of anchor line: 3 m; terminations equipped with 10-cm long loops
	steel wire rope, diameter: 10 mm	h2	
	steel wire rope, diameter: 12 mm	h3	
	Kevlar rope, diameter: 12 mm	h4	total length of anchor line: 6 m; terminations equipped with 10 cm long loops
	steel wire rope, diameter: 8 mm	h5	
	Kevlar rope, diameter: 12 mm	h6	
Flat bar	spring steel, 10 x 70 x 200 mm	s1	one termination anchored to rigid construction of the test stand and second equipped with a grip for test mass
	spring steel, 10 x 70 x 500 mm	s2	
	spring steel, 10 x 70 x 800 mm	s3	

equipped with an analog filter and a DAP 1200e measurement card (Datalog, Germany), which was a part of the computer (6). The recorded time course of test mass acceleration was stored on the computer hard disk and then processed.

Vibrations of the assembly were induced by falls of the test mass. The test mass of 100 kg (7) was positioned with a power winch (1); in that way the anchor device was lightly loaded and then released from a quick release device (2).

The anchor devices characterized in Table 1 were tested in the study.

Using the apparatus presented in Figure 3, the course of the test mass acceleration was recorded and then subjected to digital processing using Origin version 7.5 software [15]. For the determination of damped vibration frequency (f_R), the FFT algorithm was applied, and for the logarithmic decrement of damping (δ_T) approximation (maximum values of the amplitude, differing by a period) from the following function:

$$y = A_1 \cdot \exp\left(\frac{-t}{t_1}\right), \quad (2)$$

where A_1 , t_1 —parameters of an approximation function, t —time, y —amplitude.

The approximation algorithm was performed for the following points:

$$t = \frac{2n+1}{f_R} \quad \text{and} \quad y = a_{2n+1}, \quad \text{where } n = 0, 1, 2, \dots$$

The logarithmic decrement of vibration damping was calculated using the following formula:

$$\delta_T = \frac{1}{t_1 f_R}. \quad (3)$$

As a result of the tests and calculations, the results presented in Figure 4 were obtained.

On the basis of the presented results, the following observations can be made.

- The lowest values of the logarithmic decrement of damping δ_T were obtained for flat bars (s1, s2, s3), which means that vibration damping was the weakest in those cases.
- The second lowest δ_T value was obtained for horizontal anchor lines made of wire rope 8–12 mm in diameter (h1, h2, h3, h5), and then vertical anchor lines (v1).
- Horizontal and vertical anchor lines made of Kevlar rope 12 mm in diameter (h4, h6) constituted the third group with respect to δ_T values.
- The highest δ_T values were obtained for horizontal and vertical anchor lines made of twisted and braided polyamide and polyester ropes (v2, v3, v4, v5, v7).
- The greatest range of f_R (within 1.5–13.5 Hz) was obtained for flat bars (s1, s2, s3).

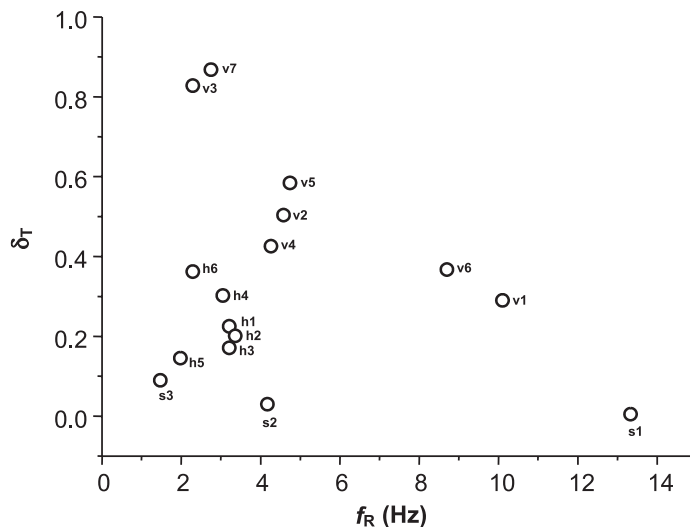

Figure 4. Test results of flexible anchor devices. Notes. f_R —damped vibration frequency, δ_T —logarithmic decrement of vibration damping, s1–s3, v1–v7, h1–h6—according to Table 1.

- In the case of horizontal steel anchor lines 6.0 m long (h5), f_R was lower than for lines 3.0 m long.
- Among anchor lines, the highest values of f_R were obtained for vertical steel and Kevlar ropes.
- Considering lines made of the same material, e.g., Kevlar rope (v6) and (h4), vertical anchor lines demonstrated higher f_R values than horizontal ones.

4. INTERMITTENT PERFORMANCE OF RETRACTABLE TYPE FALL ARRESTERS

In order to study the phenomena taking place during the operation of a retractable type fall arrester installed on an elastic anchor device, a test stand was designed (Figure 5).

A flat steel bar of $10 \times 70 \times 500$ mm was applied in the stand as a model of an elastic anchor device.

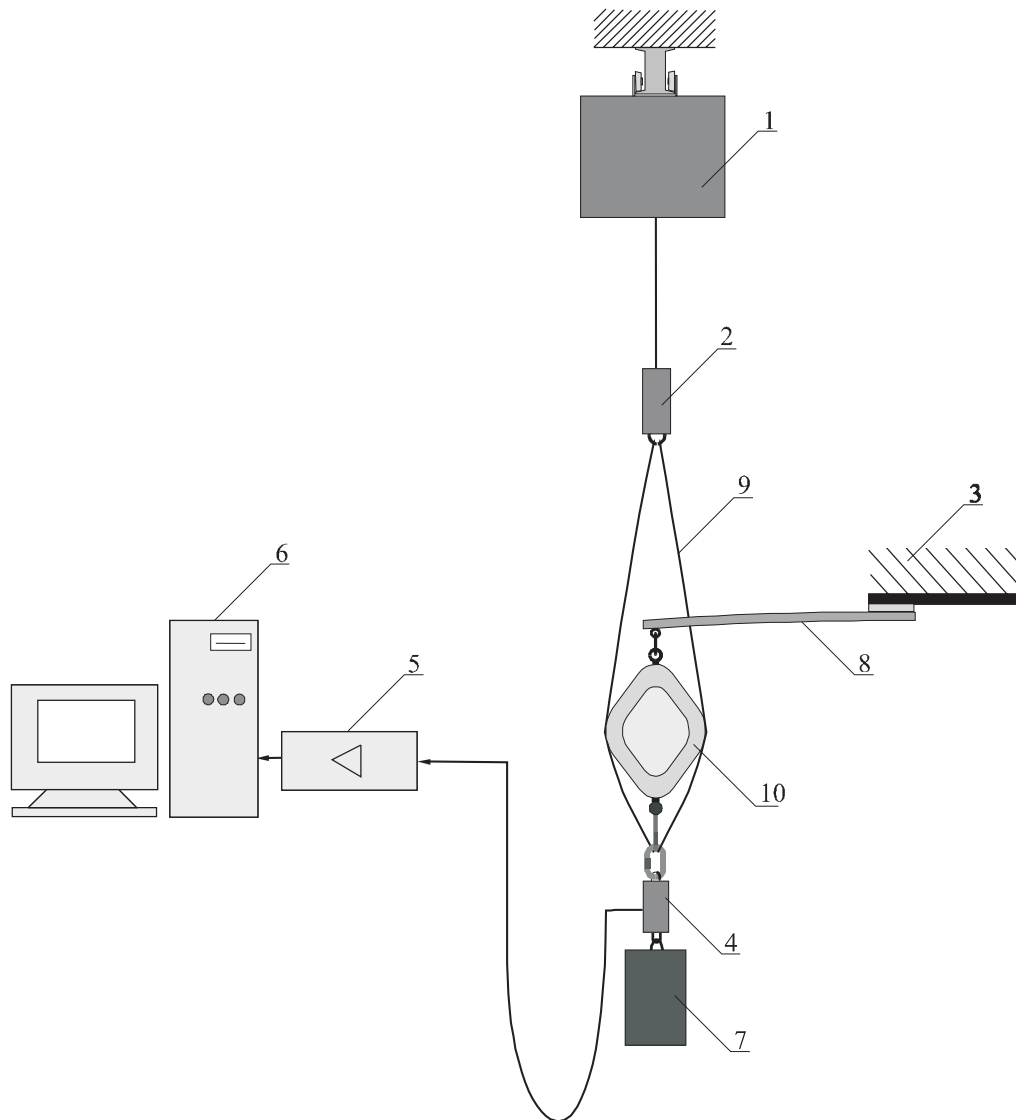

Figure 5. Test equipment and test method for retractable type fall arrester connected to flexible anchor device. Notes. 1—power winch for lifting and lowering test mass, 2—quick release device, 3—rigid construction, 4—type U9B force transducer (Hottinger, Germany), 5—type AE 101 amplifier (Hottinger, Germany), 6—personal computer with DAP-1200e measuring card type (Datalog, Germany), 7—test mass, 8—flexible anchor device, 9—flexible connector, 10—retractable type fall arrester.

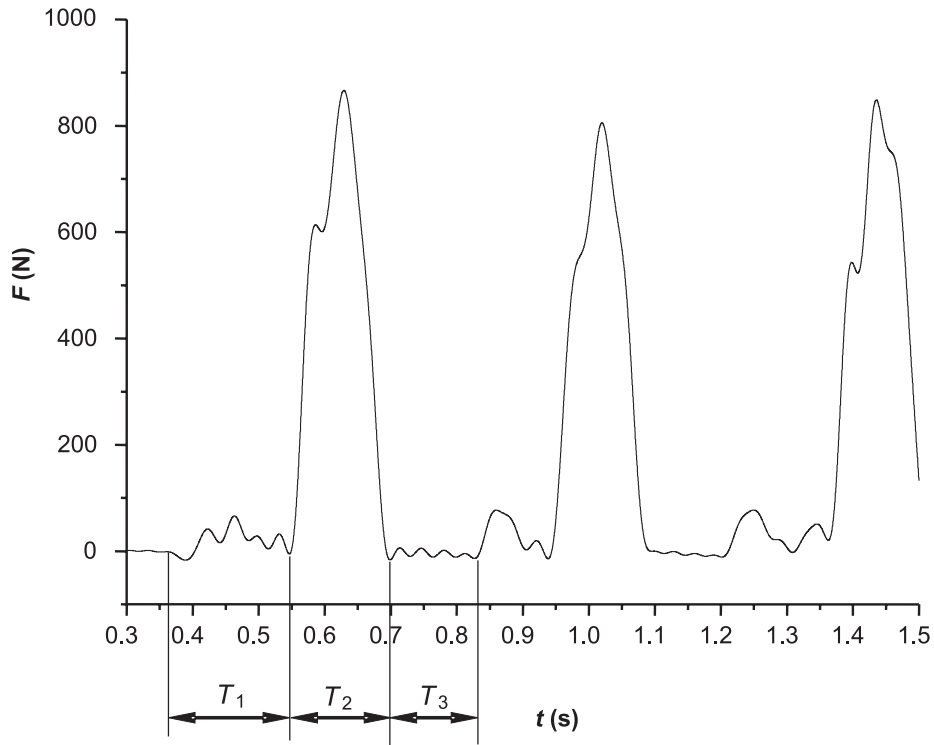

Figure 6. The force acting between a retractable type fall arrester and a test mass during fall arrest—intermittent performance of the device.

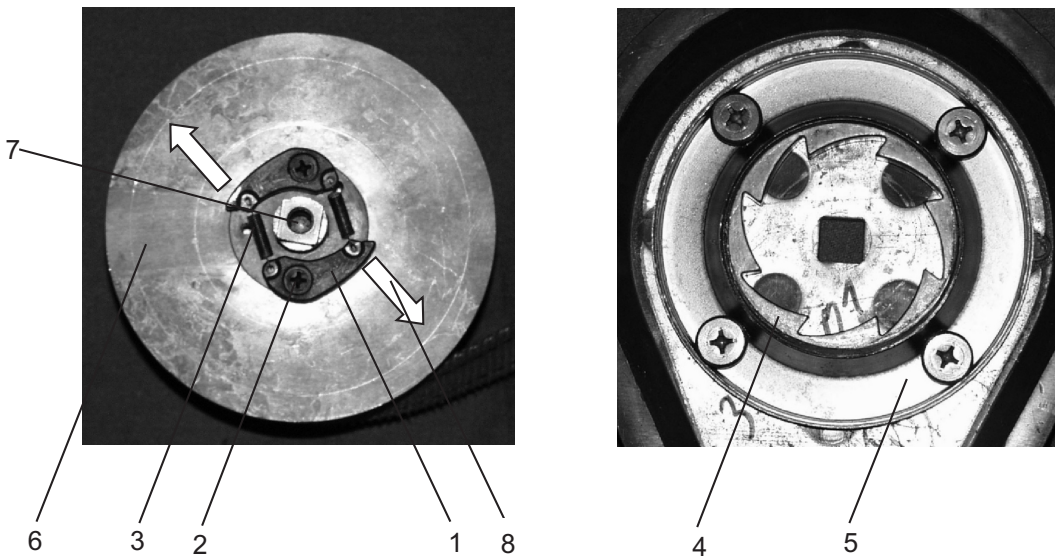

Figure 7. An example of an interlocking mechanism of a retractable type fall arrester. Notes. 1—pawl, 2—axle of a pawl, 3—spring of a pawl, 4—ring with teeth, 5—cover of friction brake, 6—retractable lanyard drum, 7—axle of a drum, 8—direction of pawls movement.

The flexural rigidity of this element was similar to the rigidity of steel constructions at worksites, which could be used as anchor devices (e.g., a 2.5-m long steel pipe 100 mm in diameter).

Intermittent performance of the retractable type fall arrester was observed during fall arrest of the

test mass. It manifested itself in a transient arrest of the fall of the mass, followed by its release and further fall. The situation is described with the recorded course of the force (Figure 6) acting between the retractable type fall arrester and the test mass.

In that course three characteristic time intervals, T_1 , T_2 , T_3 , can be distinguished. The initial moment of the T_1 interval corresponds to the start of the test mass fall. During T_1 free unwinding of the lanyard (with a negligible braking force of 15–25 N) from the drum (6) (Figure 7) and outside the device casing takes place, which is associated with increased velocity of movement of the test mass.

The centrifugal force causes the pawls (1) to loosen (Figure 7). At the final moment of T_1 the fall velocity reaches the threshold value (according to Standard No. EN 360:2002 [1] it cannot be higher than 2.5 m/s), which causes blocking of the pawls against the teeth of the ring (4). The moment of pawls are blocked initiates the T_2 time interval, in which an increase in the force acting in the retractable lanyard is observed. As a result, the friction brake is activated (5), and the lanyard and anchor device are deformed. The time interval T_2 comprises the time of brake rotation and the period of free vibrations of the anchor device–retractable type fall arrester–test mass system. As the force acting in the lanyard reaches its maximum value, the test mass reaches the lowest possible location. The further part of the T_2 interval comprises the reaction of the anchor device and the retractable lanyard, resulting in the upward movement of the test mass. Due to this movement, at the initial moment of the T_3 interval the value of lanyard tension force equals zero, and the pawls are released from the teeth of the ring (4). A repeated fall of the mass initiates the next cycle of the operation of the blockade. Such performance manifests itself in a characteristic jerking fall of the test mass until complete unwinding of the retractable lanyard.

An analysis of the presented phenomenon can lead to the conclusion that intermittent performance of a retractable type fall arrester

blockade is associated with the elastic properties of the anchor device–retractable type fall arrester–test mass system and the capability of energy dissipation demonstrated by this system. The phenomenon occurs when the energy of the falling test mass is not dissipated effectively; instead, it is accumulated in the retractable lanyard–anchor device system and returns to the test mass. The pawls then unblock and there is a further fall.

5. TESTS OF RETRACTABLE TYPE FALL ARRESTERS

After an explanation of the mechanism of intermittent performance of retractable type fall arresters, the factors contributing to the occurrence of this phenomenon were studied. For this purpose, some types of fall arresters were selected for testing. The selection was based on the following criteria.

- The devices had to comply with the essential requirements of Directive 89/686/EEC [7] and be currently used in the member states of the European Union.
- The devices had to be equipped with wire ropes and webbing.
- The friction brakes of these devices had to, under the same fall arrest conditions, produce different mean values of the braking force (according to Standard No. EN 360:2002 [1] not exceeding 6 kN).
- The retractable lanyards of specific devices should be of different lengths.

As a result of the application of those criteria, out of about 20 types of devices, 4 were selected. The parameters of these devices are presented in Table 2.

TABLE 2. Retractable Type Fall Arresters Used in Tests

Type	Material of Retractable Lanyard	Length of Retractable Lanyard (m)	Mean Value of Braking Force (kN)*	Tension Force of Retractable Lanyard (N)
A	polyamide webbing, width: 25 mm	5	4.4	<17
B	steel wire rope, diameter: 5 mm	4.5	2.2	<17
C	steel wire rope, diameter: 4 mm	10	2.6	<17
D	steel wire rope, diameter: 4 mm	25	1.6	<17

Notes. *—values determined in laboratory tests.

TABLE 3. Test Results of Retractable Type Fall Arresters

Anchor Device	Mass of Test	Type of Device			
	Mass (kg)	A	B	C	D
Rigid anchor device	10	1	1	1	1
	20	2	1	1	1
	50	1	1	1	1
Flat bar, 10 × 70 × 200 mm	10	2	15	1	2
	20	10	2	1	1
	50	4	1	1	1
Flat bar, 10 × 70 × 500 mm	10	15	12	15	3
	20	7	12	15	2
	50	15	15	15	1
Flat bar, 10 × 70 × 800 mm	10	2	15	5	3
	20	8	15	9	2
	50	15	15	15	1
Horizontal anchor line made of three-strand polyamide rope (diameter: 12 mm, total length: 3.0 m)	10	1	1	1	1
	20	1	1	1	1
	50	1	1	1	1
Horizontal anchor line made of three-strand polyester rope (diameter: 12 mm, total length: 3.0 m)	10	1	1	1	1
	20	1	1	1	1
	50	1	1	1	1
Horizontal anchor line made of steel wire rope (diameter: 8 mm, total length: 3.0 m)	10	15	5	15	1
	20	15	5	15	2
	50	15	1	15	1
Horizontal anchor line made of Kevlar rope (diameter: 12 mm, total length: 3.0 m)	10	2	2	2	1
	20	1	1	1	1
	50	1	1	1	1
Horizontal anchor line made of three-strand polyamide rope (diameter: 12 mm, total length: 6.0 m)	10	1	1	1	1
	20	1	1	1	1
	50	1	1	1	1
Horizontal anchor line made of three-strand polyester rope (diameter: 12 mm, total length: 6.0 m)	10	1	1	1	1
	20	1	1	1	1
	50	1	1	1	1
Horizontal anchor line made of steel wire rope (diameter: 8 mm, total length: 6.0 m)	10	4	2	2	1
	20	5	5	6	1
	50	1	1	2	1
Horizontal anchor line made of Kevlar rope (diameter: 12 mm, total length: 3.0 m)	10	2	2	2	1
	20	1	1	2	1
	50	1	1	1	1
Vertical anchor line made of steel wire rope (diameter: 8 mm, total length: 2.0 m)	10	3	2	2	1
	20	2	2	1	1
	50	2	1	1	1
Vertical anchor line made of Kevlar rope (diameter: 12 mm, total length: 2.0 m)	10	2	2	2	1
	20	2	2	1	1
	50	1	1	1	1
Vertical anchor line made of woven polyamide rope (diameter: 12 mm, total length: 2.0 m)	10	2	2	2	1
	20	2	2	2	1
	50	1	1	1	1
Vertical anchor line made of three-strand polyamide rope (diameter: 12 mm, total length: 2.0 m)	10	1	1	1	1
	20	1	1	1	1
	50	1	1	1	1
Vertical anchor line made of single mountaineering rope (diameter: 11 mm, total length: 2.0 m)	10	1	1	1	1
	20	1	1	1	1
	30	1	1	1	1

The selected retractable type fall arresters were tested on a stand (Figure 5). In these tests, retractable type fall arresters characterized in Table 2 were attached to anchor devices listed in Table 1. Test masses of mass $m = 10, 20$ and 50 kg were used. Using the measurement apparatus presented in Figure 5, courses of the force (Figure 6) acting during fall arrest were recorded and used as a basis for determining the number of jerks of the test mass. The tests for each test mass, retractable type fall arrester and anchor device combination were repeated five times. The obtained averaged results, rounded off to integers, are presented in Table 3.

6. DISCUSSION

An analysis of the obtained results can lead to the following observations.

- The occurrence of intermittent performance of retractable type fall arresters depends on the properties of the anchor device and the fall arrester itself.
- In most of the tested cases, the tendency towards susceptibility to intermittent performance of retractable type fall arresters decreases with an increase in the mass of the test mass subjected to fall arrest.
- A tendency towards susceptibility to intermittent performance of retractable type fall arresters decreases with a decrease in their mean value of the braking force (Tables 2 and 3).
- Intermittent performance of retractable type fall arresters is more frequent when horizontal (and not vertical) anchor lines are used.
- Intermittent performance of retractable type fall arresters (types A, B, C) is observed in the cases where logarithmic vibration damping decrement δ_T of the anchor device–rigid mass assembly does not exceed 0.4.
- Considering the results obtained within the same groups of anchor device constructions, i.e., horizontal and vertical anchor lines, intermittent performance of retractable type fall arresters is most frequent in the case of steel, and then Kevlar lines. With respect to the results presented in section 3, anchor lines made of these materials have the lowest values of logarithmic vibration damping decrement.
- The most significant susceptibility to intermittent performance is demonstrated by retractable type fall arresters mounted on flat bars made of spring steel. Those devices, according to the results presented in section 3, demonstrate the lowest values of logarithmic vibration damping decrement.
- The time interval between force impulses during the intermittent performance of retractable type fall arresters consist of times referred to in Figure 6 as T_1, T_2 , and T_3 . This indicates that the time interval is always longer than the damped vibration time for the anchor device itself (if we assume that the same test mass was used) and it is approximately $T_2 + T_3$.
- Considering anchor devices characterized by similar values of logarithmic vibration damping decrement (e.g., a 3-m horizontal anchor line and a 2-m vertical line), fall arresters installed on anchor devices with lower damped vibration frequency demonstrate higher susceptibility to intermittent performance.

7. CONCLUSIONS

The presented information has confirmed that there are specific conditions under which retractable type fall arresters protecting against falls from a height demonstrate intermittent performance. Such performance may lead to an uncontrolled displacement of the user during fall arrest, which consequently may result in injuries inflicted by dangerous objects present at the worksite.

The tests carried out within the framework of the study have demonstrated that the occurrence of intermittent performance of the devices during fall arrest is predominantly influenced by the following factors:

- the parameters (f_R, δ_T) of the anchor device;
- the characteristics of the brake of retractable type fall arrester (mean value of the braking force);
- the mass of the object the fall of which is being arrested.

The phenomenon underlying such an effect is accumulation of energy in the deformed anchor device and its release, through the retractable type fall arrester, to the mass the fall of which is being arrested. The dynamic parameters (vibration frequency and damping) of the vibratory system consisting of the anchor device–retractable type fall arrester–rigid mass, determine whether the pawls of the fall arrester will be unblocked. In the tests, fulfilling the dependences $f_R < 10$ Hz and $\delta_T < 0.4$ was the prerequisite for intermittent performance of most devices.

The obtained results also demonstrate that fall arresters tend to exhibit intermittent performance more often when arresting the falls of smaller masses than greater ones. This confirms the observation that the devices performing correctly during fall arrest of adults, exhibit intermittent performance in the case of children. Such an effect is caused by the performance of friction brakes, in which significant absorption of kinetic energy of a falling object starts after exceeding a specific threshold of the braking force, which typically falls within the 2–6 kN range. In the case of low mass, that threshold value is not exceeded and, consequently, damping of the anchor device–retractable type fall arrester–object system is low, which leads to intermittent performance.

On the basis of this phenomenon, one more conclusion can be made: using brakes with an appropriate mean value of the braking force can make it possible to develop a retractable type fall arrester posing practically no risk of intermittent performance.

The following practical conclusions can also be formulated. They are addressed both to the users and to the manufacturers of retractable type fall arresters protecting against falls from a height.

- Meeting the requirement of Standard No. EN 360:2002 [1] by a retractable type fall arrester does not guarantee its proper performance for all variants of anchorage.
- Manufacturers of retractable type fall arresters should specify acceptable anchorage conditions and the minimal mass of the user ensuring appropriate operation of the device. Such information should be included in the manual.

- If the manual of a retractable type fall arrester does not contain information concerning parameters of the anchor device, the user should apply rigid and stable anchor devices.

REFERENCES

1. European Committee for Standardization (CEN). Personal protective equipment against falls from a height—retractable type fall arresters (Standard No. EN 360:2002). Brussels, Belgium: CEN; 2002.
2. Sulowski AC. Fall arresting systems—selection of equipment. In: Sulowski AC, editor. Fundamentals of fall protection. Toronto, Ont., Canada: International Society for Fall Protection; 1991. p. 303–20.
3. Sulowski A.C. Fall arresting systems—classification. In: Sulowski AC, editor. Fundamentals of fall protection. Toronto, Ont., Canada: International Society for Fall Protection; 1991. p. 285–301.
4. Paureau J. Safe functioning of retractable type fall arresters based on tape material—theoretical analysis and test results [abstract]. In: International Fall Protection Symposium & Exhibition. Wuppertal, Germany: Bau-Berufsgenossenschaft Rheinland und Westfalen, Zentrum für Sicherheitstechnik; 1998. p. 103.
5. International Organization for Standardization (ISO). Personal fall–arrest systems—part 3: self-retracting lifelines (Standard No. ISO 10333-3:2000). Geneva, Switzerland: ISO; 2000.
6. International Organization for Standardization (ISO). Personal fall–arrest systems—part 6: system performance tests (Standard No. ISO 10333-6:2004). Geneva, Switzerland: ISO; 2004.
7. Council Directive of 21 December 1989 on the approximation of the laws of the Member States relating to personal protective equipment (89/686/EEC). Official Journal of European Communities, No. L 399, December 30, 1989, p. 18–38.
8. Baszczyński K, Zrobek Z, Jabłońska A. Opracowanie metod badania skuteczności działania blokad urządzeń samohamownych chroniących przed upadkiem z wysokości, stanowiska do badań prędkości zadzia-

- łania urządzeń samohamownych i oprogramowania pomiarowego [Preparation of test method and test stand for measurements of locking velocity of retractable type fall arresters] [test report]. Warszawa, Poland; Central Institute for Labour Protection – National Research Institute (CIOP-PIB); 2002.
9. Baszczyński K. Locking of retractable type fall arresters—test method and stand. *International Journal of Occupational Safety and Ergonomics (JOSE)*. 2005;11(2):191–202.
 10. European Committee for Standardization (CEN). Protection against falls from a height—anchor devices—requirements and testing (Standard No. EN 795:1996). Brussels, Belgium: CEN; 1996.
 11. Den Hartog JP. *Drgania mechaniczne [Mechanical vibrations]*. Warszawa, Poland: PWN; 1956.
 12. Osiński Z. *Teoria drgań [Theory of vibrations]*. Warszawa, Poland: PWN; 1980.
 13. Osiński Z, editor. *Tłumienie drgań [Vibration damping]*. Warszawa, Poland: PWN; 1997.
 14. European Committee for Standardization (CEN). Personal protective equipment against falls from a height—test methods (Standard No. EN 364:1992). Brussels, Belgium: CEN; 1992.
 15. Origin version 7.5. *Podręcznik użytkownika [User manual]*. Kraków, Poland: Gambit Oprogramowanie i Wydawnictwa Naukowe; 2004.