

Seweryn TCHÓRZEWSKI  
Silesian University of Technology  
Faculty of Organization and Management  
Institute of Management and Administration  
seweryn.tchorzewski@polsl.pl

## THE ABILITY TO INNOVATE IN A COAL MINE – AREAS AND LIMITS

**Summary.** For conducting business activities in an effective manner it is necessary to continuously renew and improve its processes, products and means of production. This improvement enables the organisation to get better results, which can be measured by increased economic activity, safety improvements, or productivity. Systematic and systemic implementation of changes designed for organization's development is necessary for the company to compete effectively on the market. The introduction of new solutions is aimed at obtaining better results but it is also a necessity resulting from the changes that occur in the surroundings of every organization. Such phenomena apply to each industry, including mining. Selected examples of areas in which innovation activities are taken in the hard coal mining sector in Poland are presented in this article.

**Keywords:** innovation, coal mine, technology transfer.

## ZDOLNOŚĆ DO INNOWACJI W KOPALNI WĘGLA KAMIENNEGO – OBSZARY I OGRANICZENIA

**Streszczenie.** Dla skutecznego prowadzenia działalności każdej organizacji niezbędne jest ciągle odnawianie oraz udoskonalanie jej procesów, produktów lub środków produkcji. To udoskonalanie pozwala na uzyskiwanie lepszych rezultatów prowadzonej działalności, mierzonych wzrostem wyniku ekonomicznego, poprawą bezpieczeństwa lub wydajności pracy. Systematyczne i systemowe wprowadzanie takich zmian, służących rozwojowi organizacji, jest niezbędne dla efektywnego konkurowania firm na rynku. Wprowadzanie nowych rozwiązań służy uzyskiwaniu lepszych rezultatów, jednak jest również koniecznością, która wynika ze zmian, jakie zachodzą w otoczeniu każdej organizacji. Zjawiska takie dotyczą każdej branży, w tym również górnictwa. W artykule zostały zaprezentowane, na wybranych przykładach, obszary, w których podejmowane są działania o charakterze innowacji, realizowane w górnictwie węgla kamiennego w Polsce.

**Słowa kluczowe:** kopalnia węgla kamiennego, transfer technologii.

## 1. Introduction

Any organisation which wants to work effectively in the future has to be taking actions associated with its development, its implementation of the changes concerning all areas of its operation- production, sales, marketing, work organisation etc. These activities can have typical investment character with the objective of obtaining means of production or other resources such as buildings, technology etc. This behaviour is natural for each venture as it allows it to maintain and develop production capacity in a way it meets the market demand for products it offers. However, just renewing or increasing the ability of the venture to offer its products or services is inadequate. For conducting business activities effectively in the long term it is necessary to compete with other economic entities by using new ideas transformed into products, management systems and process management. These new ideas are called innovations.

According to the OECD<sup>1</sup> innovation is introducing to economic practices a new or substantially improved solution in respect of a product (goods, services), process, marketing or organisation. In the industry-specific literature the concept of innovation has been often discussed but for the purposes of this publication when talking about innovations we will use the GUS terminology where the following concepts were highlighted and discussed:

- product innovation, related to goods, products; any changes resulting in significant improvement of products which have already been manufactured in the past or introduction of new products to the offer; product innovation is not e.g. the introduction of shielding netting (for the lining of the mine workings) made from steel with different parameters, but innovation is introducing of the netting made of other materials than steel e.g. composite netting,
- process innovation (technological innovation) which are the changes in the methods already used during production or while providing services; in particular changes in the organisation of production or changes in equipment used for production; the purpose of such innovations is increasing the efficiency of production; process innovation is e.g. the introduction of remote control for equipment which enhances the safety of mining activities or exploitation works,
- organisational innovation, new methods of organisation in business practices of the business entity, workplace organisation or external relations of the company; unless nowadays in the hard coal mining in Poland we do not consider the introduction of 24/7 exploitation system (7 days a week, 24 hours a day) as an innovation, then the introduction of quality management or project management rules in practice in the coal mines is not an organisational innovation,

---

<sup>1</sup> Source [23].

- marketing innovation, in turn, means a significant change in the appearance of the product, the manner of its presentation, positioning or promotion, however, due to the nature of the product which is hard coal, innovation in this area is difficult. Yet another factor in the process of introducing the innovation to a business entity which is taken into consideration is the time that passes from the introduction of a similar solution by other entities. That's why an innovation is an action which has not been taken previously by other entities:
  - in the scale of a region, in a period of less than 1 year,
  - on a national level in a period of less than 3 years,
  - on an international level in a period of less than 5 years.

At the same time it has to be pointed out that although many organisations are engaged in research and development activities not every discovery or invention which these organisations develop is an innovation. This is so because the deciding factor whether a discovery or invention is an innovation is the transformation of the idea into a product which can be introduced into the market.

## **2. Breakthroughs in mining industry**

Mining is inextricably linked to the activities and development of humans. The search of different kinds of minerals for the production of tools and thus making everyday life easier was a natural necessity of human beings. Silica, iron and coal are the next steps in the development of needs but also the next step when it comes to extractive technology and other areas of science and technology. The most famous examples of innovation connected with mining but at the same time having influence on the society are:

- introduction in the second half of 18th century first steam-powered machines- pumps which enabled to drain mines. Until this time it was only possible to mine almost solely thanks to the gravitational water drain so in a case when a mine was located on the slope of the hill. The introduction of pumping machines allowed opening of standard, common today underground mines.
- a result of the development of above mentioned steam-powered machines was the invention of the railway at the beginning of the 19th century which enabled mass transport of people and supplies over long distances; the use of the railway with regard to the mining industry first and foremost made it possible to resign from the attachment to water transport of coal, iron ore and slate as a means of mass transport of the dredged material, secondly, to abandon the underground transport of it by animals, and increase the efficiency of underground transport of people and material,

- the development of modern explosives by Alfred Nobel at the end of the 60s of the 19th century along with the parallel introduction of pneumatic drills and diamond core drilling crowns increased the safety of mining works and was yet another contribution to the increase of labour productivity of miners,
- the introduction of mechanization of mining works- including the mechanised roof complex, which started to become popular in the middle of the 20th century and immensely increased the labour productivity in mines.

Mining industry, like every other area of our lives, absorbs solutions which enable its current activity and development. Virtually every new area of technology or organisation of work is assumption for its development. A typical example from the last several years is a kin dog revolution accompanying the introduction of IT solutions into mining which is especially visible in the fields of geology and geodesy. The introduction of the digital maps of the deposits and objects on the surface and underground has speeded up the evaluation process, design, progress monitoring while taking into account environmental and safety factors.

These ground-breaking developments in the mining industry have not only directly led to its development but also had an impact on the development of its surroundings.

### **3. Innovation in mining based on statistics**

GUS – Central Statistical Office of Poland is an institution collecting information about the society as a whole and the specific areas of its operation. One of these areas is the innovative activity of enterprises. GUS analyses it in terms of developments as it is the key to the development of enterprises and as a consequence to the development of the whole country. Regularly prepared reports [6–9] present the state of innovative activities carried by enterprises in the aforementioned years.

Taking into account the data about the innovation activities related to mining summarized in Figure 1 it can be stated that the amount of innovation in the field of mining and construction, despite a significant increase in the years 2010-2011 measured quantitatively and judged by the percentage of the submitted applications has decreased in the last few years. Unfortunately, the statistics which are officially available do not allow to determine the causes of this state of affairs.

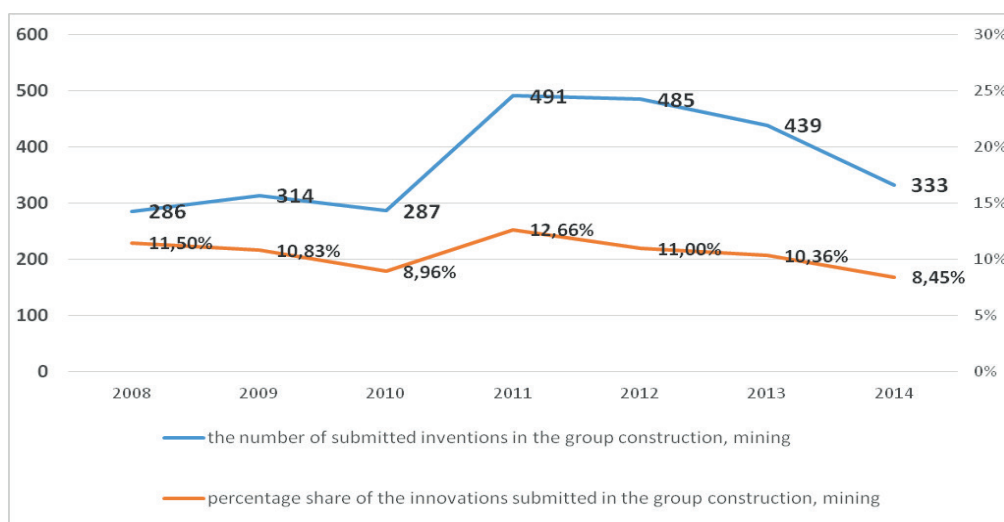

Fig. 1. Number of submitted inventions in the group construction, mining compared to all applications (in percentage) in the years 2008 – 2014

Rys. 1. Liczba wynalazków zgłoszonych w grupach budownictwo i górnictwo w porównaniu do wszystkich zastosowań (w procentach) w latach 2008 – 2014

Source: Own work on the basis of [26-32].

#### 4. Examples of innovation introduced in selected areas of hard coal mines

As indicated earlier, the realisation of innovation in the mining sector, as well as in other sectors, is related to all areas of its activities <http://en.pons.com/translate/english-polish/well>. Below you can find selected examples of innovations introduced over the past few years in the mining industry, both by companies producing coal and companies related to coal mines such as suppliers of machines and equipment, service providers.

##### Integration of a heading machine with a drilling rig and an anchoring machine

High costs of labour of sidewalks in the support lining (arched) and better and better anchor lining technologies, make the manufacturers of heading machines equip them with anchoring equipment.

An example of a heading machine MR 340 produced by the company SANDVIK equipped with a drilling-anchoring device type BU 2500. This device is fixed in a central position on a heading machine and is completely integrated with it (fig. 2). Hydraulic system is powered by the heading machine's power generator and remote (radio) control is carried out through heading machine's power supply. While the heading machine is excavating the rock mass the drilling-anchoring device remains inactive and is in the parking position at the back of the heading machine. When the excavating process is finished, the device is slid into the front of the excavating arm and the process of building the rockbolt support begins (fig. 3). Remote control of the device allows for quick and very safe execution of these works.

Installed anchors (up to 2,5 m long) can be placed in both the roof and in the mine workings (pic. 1).

Combining the heading machine with the drilling-anchoring device thanks to the mechanisation of the works and elimination of changing the devices in the coalface increases the speed of drilling the mine workings, improves the security and work comfort.

Interestingly, the use of integrated underground drilling rig and anchoring device is not a new solution- it is used on daily basis in the mining of copper ore (KGHM S.A. - Kombinat Górniczo-Hutniczy Miedzi is one of the largest producers of copper and silver in the world). However, in the case of hard coal mining it is an innovative solution.

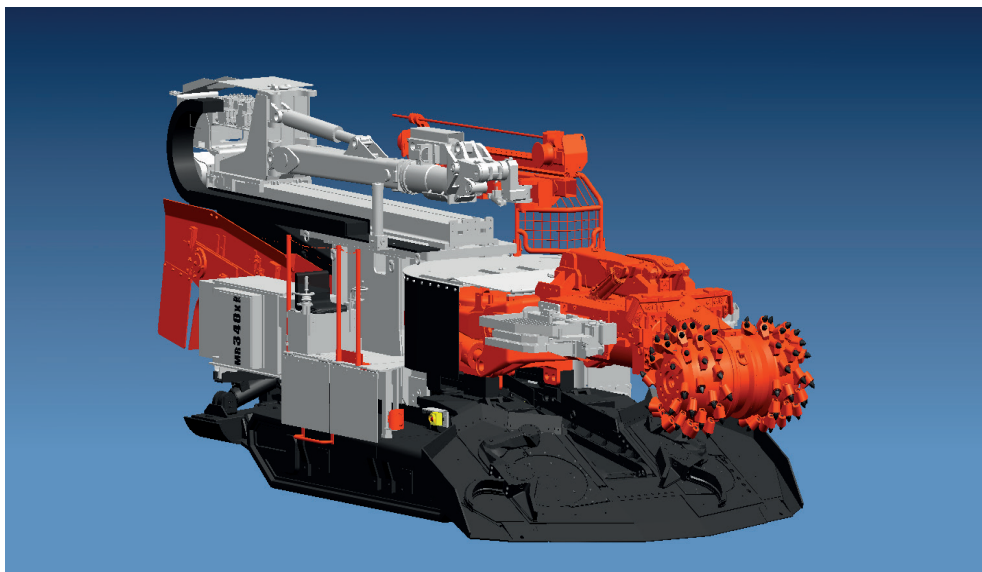

Fig. 2. Heading machine MR 340 with a drilling-anchoring device BU 2500 in the parking position  
Rys. 2. Kombajn chodnikowy MR 340 z urządzeniem wierząco-kotwiącym BU 2500 w pozycji spoczynkowej

Source: Materials owned by Sandvik Mining and Construction Sp. z o.o, by courtesy of the company.

An example of the above mentioned solution in the hard coal mining is drilling capital headings in PG Silesia where the anchoring of the mine workings is done right after the face is unveiled by the heading machine. Anchoring is followed by putting a quick-setting material into the gaps between the rockbolt support and the face. As a result, the rockbolt support becomes more stable and there is no need to carry out any maintenance works in the period of 16 months after work completion and the heading section is only narrowed by max 10 cm.

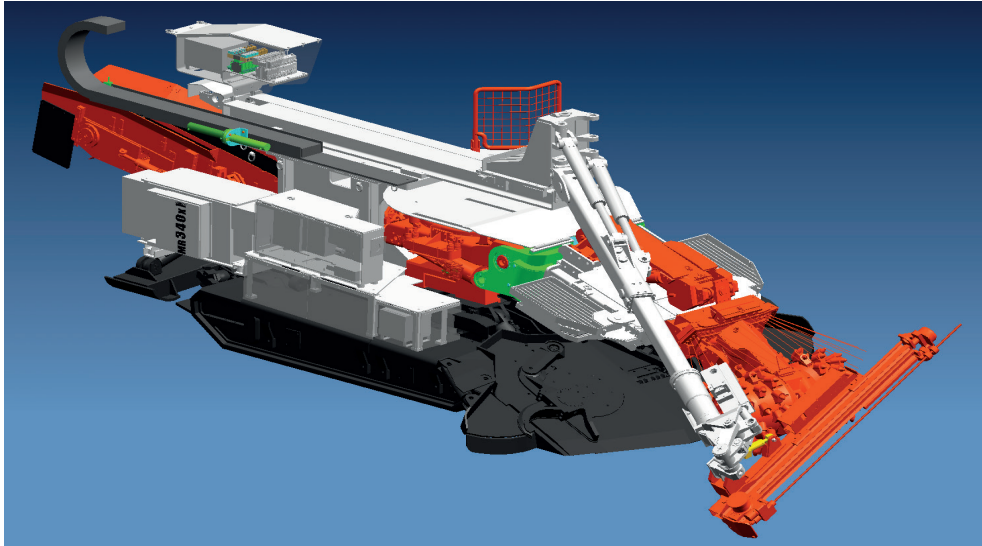

Fig. 3. Device BU 2500 in the working mode

Rys. 3. BU 2500 w pozycji roboczej

Source: Materials owned by Sandvik Mining and Construction Sp. z o.o, by courtesy of the company.



Pic. 1. Remote control of the anchoring process

Fot. 1. Zdalne sterowanie procesem kotwienia

Source: Materials owned by Sandvik Mining and Construction Sp. z o.o, by courtesy of the company.

Interesting is also a simultaneous borrowing of this technology by copper ore mining from the hard coal mines. An example of such a borrowing is the preparation by the company KOPEX S.A. a mechanised face complex, customised to the needs of copper ore mining.

### **Constrictive netting made of basalt (made by [16] – by courtesy of the company)**

Since 2014 a new material is produced and used in practice replacing the previously used steel netting (constrictive) allowing for protection of roof and the min workings from the rock precipitation (pic. 2). This netting can be used at the same time on the surface to protect the construction works- scarps, trenches and other lowerings of the ground where there is a risk of the loss of scarp's stability.

The netting is made of basalt fiber enriched with special additives making it highly durable. The fibres are combined by means of resin and form characteristic stripes which are approximately 50 mm wide. Interconnected stripes (glued together by resin) form a netting with eyelets spaced every 100 mm with a possibility of a further consolidation.

The main advantage of the solution described above is its low weight- it is approximately 5 times lower in terms of  $m^2$  of the material than a traditional steel constrictive netting. The second advantage is the ability to be transported in rolls, from which individual segments used to secure the mine workings are cut off by means of ordinary scissors (fig. 3).



Pic. 2. Constrictive netting Pollux put in the mine workings

Fot. 2. Kompozytowa siatka opinkowa Pollux w zastosowaniach górniczych

Source: Materials owned by PPUW Ankara, by courtesy of the company.





Pic. 3. Cutting the netting on the mine working to the correct size  
Fot. 3. Przycinanie siatki opinkowej do żądanego wymiaru  
Source: Materials owned by PPUW Ankara, by courtesy of the company.

### Moving walkway with a handrail

Another example of a simple but effective solution increasing the comfort of miners work was the introduction (also in PG Silesia) of a moving walkway with a handrail. This simple device is a handrail loop driven by an electric motor moving in the speed of a marching person (fig. 4). This solution makes it significantly easier to be on the move in inclined galleries of the mine, proving especially useful towards the end of the shift, improving the comfort of the people returning from the coalface.

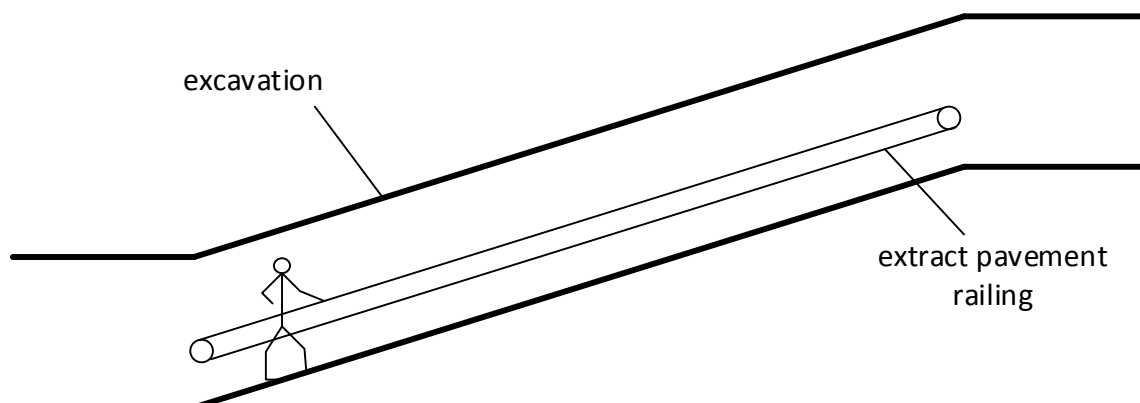

Fig. 4. Diagram showing the usage of moving walkway with a handrail  
Rys. 4. Schemat zastosowania ruchomego chodnika z poręczą  
Source: Own work.

**The usage of digital maps for the design process and planning of the mine activities**

One of the main tasks of plane surveying is taking measurements in the mine workings and illustrating them on the map. Nowadays, analogue maps drawn in ink on a rigid foundation of the map are still in use but also numeric (digital) maps, which applicability has been increased in the last twenty years, are being introduced. A numeric map of mining workings is a database in which, through appropriate land surveying programs, the position in space of blocks, lines and points in relation to one another has been clearly specified by assigning to them exact attributes which in turn allows a quick identification of these objects. This solution allows for a quick reproduction of the maps and traditional archives which used to occupy large spaces are minimised into one rack where the data saved on a disk is stored. Another advantage of digital maps is the visualisation of the objects on a computer screen, thanks to which we are going even further into the direction of an interactive digital map.



## 5. Benefits and constraints in the implementation of innovation in hard coal mines

In respect of mining industry, innovation activities are conducted by companies from all areas and of each scale- mines and partnerships, suppliers of machines, devices and materials, technology and organisational providers, small, medium and big companies.

All these companies, in different scales, carry out research which allow them to compete on the market. The benefits of innovation for the companies connected with the mining industry are analogous to those achieved in other areas of economy, namely:

- improvement and further development of manufactured goods [12],
- improvement and further development of production processes [1, 4, 18],
- improvement of work organisation and management [2, 5, 13],
- improvement of marketing [19],
- improvement of financial management [4, 24, 25],
- improvement of human resources management [3],
- introduction of new technologies [20, 22],
- introduction of new products [12, 16, 22].

A problem that has been always associated with the implementation of innovation is the resistance of the people against the introduction of a widely understood „novelty”. This resistance is also varied, depending on the area in which the innovation is introduced and on the industry. In addition to the typical psychological barriers, each innovation is accompanied by barriers resulting from economic (in recent years affecting in particular coal mining) and bureaucratic constraints. Their impact is often a major strength, with which the company’s management have to face. What is important, however, is the removal of these psychological and bureaucratic barriers. They should be abolished firstly by means of discussions and communication with the staff of the organisation, and only in case of failure it should be introduced as an order.

Coal mining in Poland, despite the current difficult economic situation, is still an industry in which improvements, novelties- innovation are introduced. Such an approach, albeit with difficulty, still allows for keeping pace with changes that occur in the industry around the world. This brings hope for future of this already disadvantaged industry.

Despite of today’s problems in coal mines, creation and application new ideas, new solutions is important to survived on this trade. Only when we change organisation we have a chance to succeed on very difficult market.

## Bibliography

1. Adamecki Sz., Adamiec P., Tchórzewski S.: Drażenie wyrobisk korytarzowych o znacznym nachyleniu w Przedsiębiorstwie Górniczym „Silesia”. „Wiadomości Górnicze”, nr 2, 2015.
2. Brzychczy E., Mieszaniec J.: Wpływ zarządzania wiedzą na innowacyjność i konkurencyjność przedsiębiorstw górniczych. „Wiadomości Górnicze”, nr 2, 2011.
3. Bąk P.: Benchmarking jako innowacyjny instrument zarządzania przedsiębiorstwem. „Wiadomości Górnicze”, nr 2, 2011.
4. Brzychczy E., Mieszaniec J.: Zastosowanie systemów informatycznych do wsparcia innowacji organizacyjnych w przedsiębiorstwach górniczych. „Wiadomości Górnicze”, nr 11, 2011.
5. Dobeś A., Tchórzewski S.: System zarządzania projektami w Przedsiębiorstwie Górniczym „Silesia”. „Wiadomości Górnicze”, nr 3, 2013.
6. Działalność innowacyjna przedsiębiorstw w latach 2010 – 2012. GUS, Urząd Statystyczny w Szczecinie, październik 2013.
7. Działalność innowacyjna przedsiębiorstw w latach 2006 – 2008. GUS, Urząd Statystyczny w Szczecinie, wrzesień 2009.
8. Działalność innowacyjna przedsiębiorstw w latach 2005 – 2007. GUS, Urząd Statystyczny w Szczecinie, listopad 2008.
9. Działalność innowacyjna w Polsce. Urząd Statystyczny w Szczecinie, październik 2014.
10. Dyczko A., Dunst N., Galica D.: Wykorzystanie narzędzi informatycznych do modelowania złoża węgla kamiennego. „Wiadomości Górnicze”, nr 9, 2014.
11. Dziubińska A.: Uwarunkowania innowacji strategicznej w pozyskaniu nowych źródeł przewagi konkurencyjnej. Perspektywa przemysłu wydobywczego. „Przegląd Górniczy”, nr 9, 2010.
12. Dziura J.: Kompleks „Mikrus” – nowa technologia wybierania pokładów cienkich. „Wiadomości Górnicze”, nr 3, 2013.
13. Głodzik S., Jasiewicz J., Magda R., Woźny T.: Innowacyjne planowanie i projektowanie dla potrzeb zarządzania produkcją górniczą. „Przegląd Górniczy”, nr 9, 2010.
14. Herman M., Gaj B., Wójtowicz W.: Modernizacja szybu „Nr 2” w Przedsiębiorstwie Górniczym „Silesia”. „Wiadomości Górnicze”, nr 12, 2014.
15. Holeksa A., Budziszewski Z., Pluta Z., Dobrzyński R.: Osiągnięcia techniczne i technologiczne kopalń JSW S.A. „Wiadomości Górnicze”, nr 10, 2013.
16. Polus M.: Instrukcja stosowania siatki z włókna bazaltowego typu POLLUX 1 oraz POLLUX 2. Materiały firmowe, PPUW ANKARA, Edycja 1, Kraków, styczeń 2015.
17. Janusz T., Lewandowska L.: Podręczny słownik Menedżera. RES Polonia, Łódź 1993.

18. Karbownik A., Wodarski K.: Możliwości techniczne i uwarunkowania ekonomiczne projektowania eksploatacji resztkowych złóż węgla kamiennego. „Przegląd Górniczy”. nr 9, 2011.
19. Kijewska A.: Benchmarking – wdrażanie najlepszych praktyk – szansą poprawy dzielności przedsiębiorstwa. „Przegląd Górniczy”, nr 9, 2009.
20. Kołodziejczyk P., Miśkiewicz K.: Sieci bezprzewodowe w kopalniach podziemnych – właściwości, ograniczenia, możliwości wykorzystania. „Wiadomości Górnicze”, nr 5, 2013.
21. Mieszaniec J.: Nakłady na działalność innowacyjną i ich struktura w przedsiębiorstwach górniczych. „Przegląd Górniczy”, nr 9, 2011.
22. Nierobisz A.: Górnictwo w przestrzeni kosmicznej. „Wiadomości Górnicze”, nr 9, 2013.
23. Oslo M: Guidelines for Collecting and Interpreting Technological Innovation Data. 3rd Edition, OECD/Eurostat, Paris 2005.
24. Rotkegel M., Szot Ł., Witek M.: Zastosowanie nowoczesnych narzędzi w projektowaniu obudowy chodnika podstawowego w pokładzie 510 w Zabytkowej Kopalni Węgla Kamiennego „Guido”. „Wiadomości Górnicze”, nr 7-8, 2015.
25. Stańczyk A.: Centrum Usług Wspólnych KHW S.A. modelowym rozwiązaniem dla górnictwa. „Przegląd Górniczy”, nr 9, 2011.
26. Urząd Patentowy RP, raport roczny 2008.
27. Urząd Patentowy RP, raport roczny 2009.
28. Urząd Patentowy RP, raport roczny 2010.
29. Urząd Patentowy RP, raport roczny 2011.
30. Urząd Patentowy RP, raport roczny 2012.
31. Urząd Patentowy RP, raport roczny 2013.
32. Urząd Patentowy RP, raport roczny 2014.

## Omówienie

W artykule przedstawiono zróżnicowane przykłady (pod względem skali i jakości) innowacji, jakie miały miejsce w górnictwie węgla kamiennego w Polsce. Patrząc na górnictwo węgla kamiennego przez pryzmat tych przykładów, możemy zaobserwować zmiany, które w dłuższej perspektywie mogłyby dać mu szansę na przetrwanie i dalsze funkcjonowanie tego sektora w obecnej, trudnej sytuacji gospodarczej.