SAFETY ENGINEERING OF ANTHROPOGENIC OBJECTS

SELECTED TECHNICAL AND LEGAL ASPECTS OF THE PNEUMATIC LAUNCHER OPERATION FOR HOPKINSON MEASURING BARS SET

Kamil Sobczyk

Military University of Technology
ORCID: 0000-0002-5929-757X

Leopold Kruszka

Military University of Technology
ORCID: 0000-0001-5129-2531

Ryszard Chmielewski

Military University of Technology
ORCID: 0000-0001-5662-9180

Ryszard Rekucki

Military University of Technology
ORCID: 0000-0002-2040-7073

Abstract

The paper presents selected technical and legal areas of the exploitation of a pneumatic launcher as an essential part of the mechanical test stand of the split Hopkinson bar for testing the dynamic properties of construction materials. The process of impact loading of the tested material sample is carried out by means of a loading bar-projectile fired from this launcher. The concept of the first stage of the modernization of the pneumatic launcher used at the Institute of Civil Engineering of the Military University of Technology (MUT) for over 20 years was discussed in order to facilitate the performance of physical experiments. The formal and legal requirements for the design, construction and usage of a test stand with a pneumatic launcher in a laboratory room are presented.

Key words: pneumatic launcher, split Hopkinson bar, test stand operation



INTRODUCTION

The split Hopkinson bar is currently used in many Polish and foreign research and development centers and industry to study the behavior of various construction materials (e.g. mortar, concrete, steel or soil) subjected to a load with a high strain rate (HSR). The results of these studies are applicable in many fields of technology, including protective building structures, e.g. for design sand cover for protective shelters for civilians [13]. One of the most important elements of the test stand is the pneumatic launcher system. The operation of this device - a pneumatic launcher - depending on its parameters, allows the bar-projectile to accelerate from a few to several hundred meters per second. The differences result from the specificity of the working medium used (the most frequently used gases: helium, hydrogen or compressed air) and the internal structure of the launcher system - a bar-projectile loading the Hopkinson measuring bar system.

In this paper, an analysis of selected legal aspects (in accordance with the currently applicable regulations in Poland) and technical aspects of the exploitation of a pneumatic launcher was carried out on the example of a loading bar-projectile launcher device that has been regularly used for two decades. The first stage of its modernization was proposed in order to facilitate the conduct of physical experiments with the use of an electromagnetic valve.

1. Selected legal issues

Tests of dynamic properties of construction materials, including construction soils, require physical experiments on specially prepared test stands that are much more complex than static and quasi-static strength tests, which are performed on conventional machines such as INSTRON, MTS, ZWICK [2, 3], and in the case of soils: on a shear or triaxial compression apparatus, based on standards [4, 5]. On the other hand, dynamic tests are not covered by the standards, with the exception of tensile testing of metal sheets in order to determine their "stress-strain" strength characteristics at high strain rates [9]. This standardization document, first introduced in 2010, specifies the use of Hopkinson measuring elastic bars. The range of deformation rate in the range from 10^{-3} 1/s (static) to 10^3 1/s (dynamic) is considered in this standard to best reflect car accidents based on experimental and numerical calculation methods, including energy analysis related to damage resistance accidents of a motor vehicle

using the finite element method. Hence, this document states that: "to assess the crashworthiness of a car with the desired accuracy, the stress-strain characteristics of metals at strain rates higher than 10^{-3} 1/s are necessary" and that this test method covers strain rates in the range above 10^2 1/s.

The mechanical part of the current Hopkinson bar test stands consists of a pneumatic launcher used to launch a loading bar-projectile or a cylindrical sample in the modified Taylor impact test and measuring bars operating in the elastic range. These test stands are made on the basis of individual project (workshop) documentation. The technical documentation of this technical device should meet all the necessary requirements for machines [10] and the principles of operation of the Hopkinson bar research technique (this position is not used temporarily, but is used on a permanent basis, i.e. both in research projects and for teaching purposes). The formal and legal requirements include the following generally applicable legal acts and relate to the safety of using this test stand with a pneumatic launcher in a laboratory room publicly accessible to both students and university employees:

- 1) the so-called. machinery directive [1]: although "machines designed and constructed specifically for research purposes for temporary use in laboratories" are excluded from this directive, due to health and safety issues at universities [11], the requirements of this directive should be taken into account in particular, equipping both the test stand and the laboratory room with ballistic protective elements during dynamic physical experiments, this applies in particular to testing brittle materials, when during the dynamic process of sample destruction, fragments are formed that move at high speed beyond the test stand, causing a direct risk of loss of life or serious damage to health of people staying in this laboratory;
- 2) the act on technical inspection [7], covering the design, production and operation of the test stand, in particular the pressure tank of the pneumatic launcher as the so-called tank installation;
- 3) the act on weapons and ammunition [8]: in particular, this applies to a pneumatic launcher as a pneumatic weapon - a device that is dangerous to life or health, which, as a result of the action of compressed gas, is capable of firing a projectile from a barrel or its replacement and thus capable of destroying the target at a distance, and the kinetic energy of the projectile leaving the barrel or its replacement exceeds 17 J;
- 4) the act on economic activity in the field of manufacturing and trading in explosives, weapons, ammunition and products and technology for military or police purposes [14]: that the plant producing the pneumatic launcher has an appropriate license from the Ministry of Interior and Administration in this respect [12];

5) the act on the protection of persons and property [15] in the field of technical security of the laboratory room, in which there is a test stand with a launcher - pneumatic weapon, including anti-burglary doors and windows.

Currently, foreign companies offer the sale of commercial test stands based on the Hopkinson bar technique, equipped with a single-stage pneumatic launcher, meeting the above requirements [1, 7, 8], including those marked with the CE mark [16-20]. However, the cost of purchasing this type of test stand is very high.

2. Description of the existing pneumatic launcher

A test stand of a split Hopkinson bar is used to test the properties of building construction materials at high strain rates. It is located in the laboratory for testing materials and structures on the dynamic impact of the Institute of Civil Engineering of the Military University of Technology

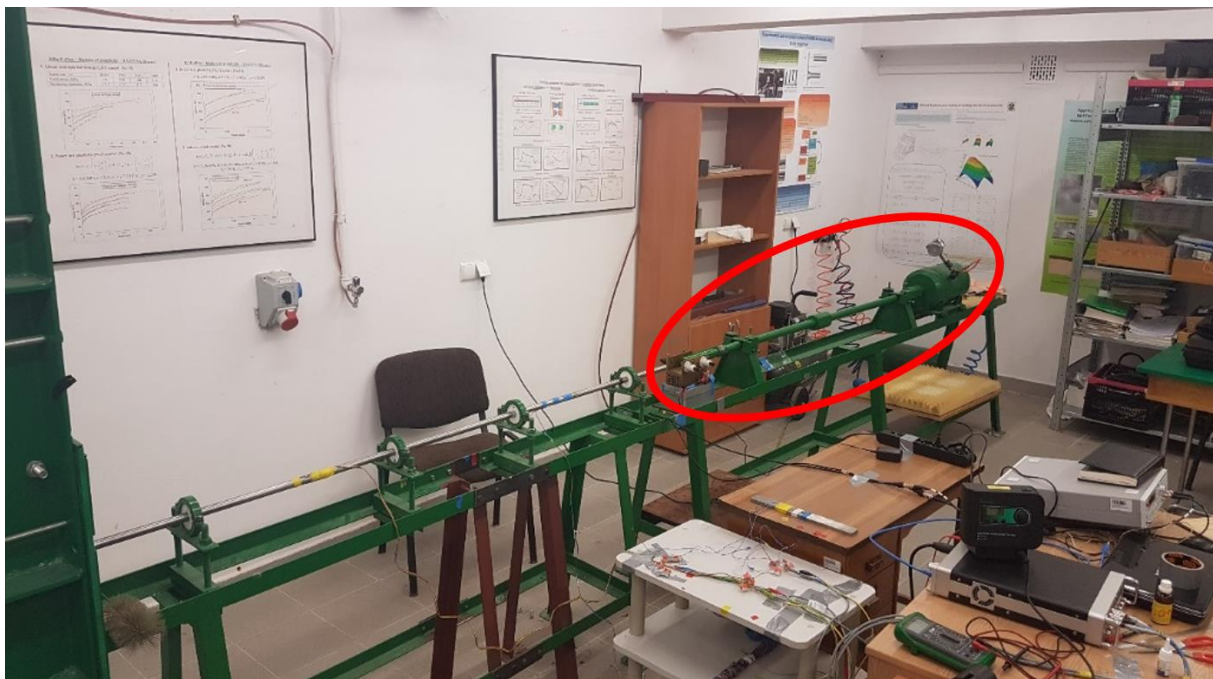

Figure 1. *Split Hopkinson bar test stand (with a red circle marking - pneumatic launcher with barrel and stand base painted green).*

The mechanical part of this test stand consists of the following components:

- pneumatic launcher with a barrel – a guide of loading bar-projectile;
- measuring bars: initiating and transmitting with a damper.

Between the measuring bars there is a test sample of material subjected to dynamic load as a result of the impact of the bar-projectile at a given speed. Fig. 2 shows a diagram with the key elements of a split Hopkinson bar with a red circle marking the longitudinal section of the air launcher pressure tank.

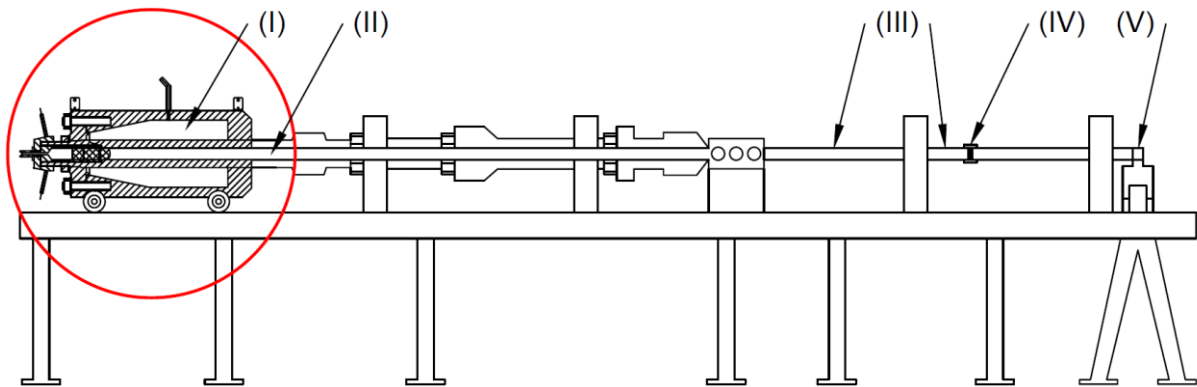

Figure 2. *The key elements of a split Hopkinson bar: a pneumatic launcher (pressure vessel (I) with a barrel (II) containing a cylindrical loading bar-projectile) with measuring bars (III), the tested sample (IV) and a damper (V).*

Pneumatic launcher systems [6] fall into different categories depending on:

- type of energy source (gas) in the pressure vessel;
- number of pressure system stages;
- variant of the trigger mechanism;
- version of the barrel used;
- type of energy source mechanism.



Figure 3. *Pneumatic launcher*

The launcher shown in Fig. 3 is powered with compressed air supplied from a SPECAIR air compressor - Fig. 4.



Figure 4. Air compressor

The analyzed launcher has a single stage pressure system and a smooth barrel. The trigger mechanism is manually actuated via a manual valve and the loading bar-projectile is continuously driven by compressed air. The assignment of this pneumatic launcher to a given category is marked in orange in Fig. 5

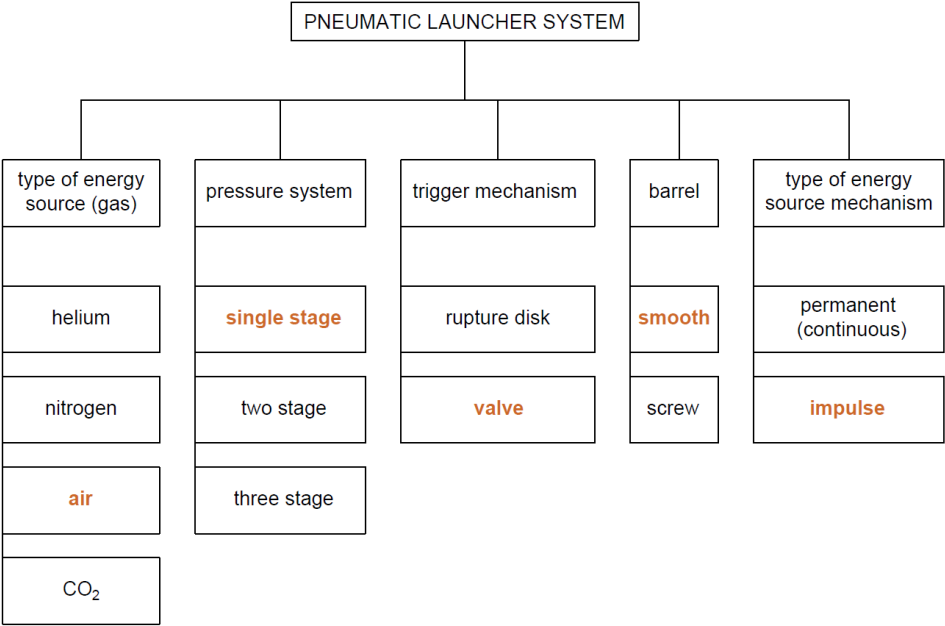

Figure 5. Scheme of division into categories of pneumatic launcher systems [6].

3. Modernization of the pneumatic launcher

The current procedure for preparing the pneumatic launcher for the firing of the load bar-projectile is complex and consists of several stages. First, you need to unscrew the bar-projectile feeder at the back of the launcher (A). Then put two sealing O-rings (B) and the centering ring on the bar-projectile (C) - place such a set in the feeder. The feeder prepared in this way is placed in the barrel of the launcher (D) inside the pressure tank (E) and tightened. Connect the hose from the air compressor and fill the launcher chamber through the hose number 1 (F) using compressed air at the appropriate pressure. At the same time, the air supply to space behind the bar-projectile in the barrel through the hose no. 2 (G) should be closed. After filling the launcher chamber to a certain pressure value, shut off the air supply through hose 1 - the pressure value in the launcher chamber determines the strength and speed of the bar-projectile firing. Then, supplying compressed air through hose no. 2 to space in the barrel behind the projectile will push the bar-projectile and connect the launcher chamber with the space behind the bar-projectile - the pressure will be equalized. Rapid manual unscrewing of the feeder assembly causes a sudden increase in volume for the compressed air and a shot takes place - driving the bar-projectile to the desired value of the impact velocity on the forehead of the initiating Hopkinson bar. The experience gained so far related to conducting dynamic physical experiments has allowed us to propose the modernization of the test stand by using a modern electromagnetic valve (H) with a short time of its opening and closing. The task of such a valve will be to simplify the firing procedure: the electrical signal controlling this valve will cause a sudden and controlled initiation of the bar-projectile firing without the need to manually unscrew the feeder assembly.

Fig. 6 and Fig. 7 present the current and modernized version of the pneumatic launcher with the use of an electromagnetic valve.

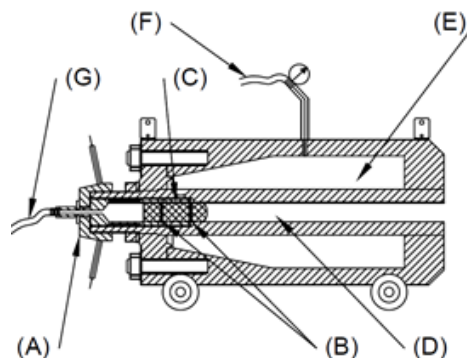

Figure 6. Current version of the pneumatic launcher (letter marking parts are in the text).

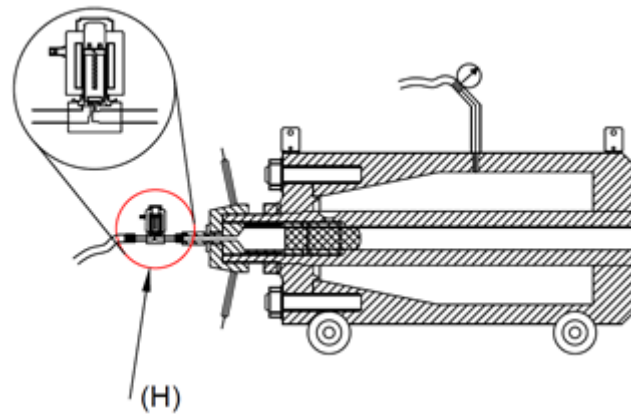

Figure 7. Modernized version of the pneumatic launcher with an electromagnetic valve.

CONSLUSION

The paper presents selected technical and legal issues related to the design, construction and usage of a pneumatic launcher, which is one of the essential elements of the test stand for the mechanical part of the split Hopkinson bar, based on the example of using the test stand split Hopkinson bar in the laboratory for testing materials and structures on the dynamic impact of the Institute of Civil Engineering MUT. The first stage of modernization of the pneumatic launcher of this test stand was also proposed by using an electromagnetic valve for the pneumatic launcher system, which will significantly improve the initiation of the firing of the loading bar-projectile.

REFERENCES

- [1] Directive 2006/42/EC of the European Parliament and of the Council of 17 May 2006 on machinery, and amending Directive 95/16/EC (recast) (OJ L 157, 26, 9.06.2006).
- [2] Shalobyta N.N., Shalobyta N.N. (2019). „Stress-strain state of the flexible element with composite unremovable formwork”. *Safety Engineering of Anthropogenic Objects*, No 3 (2019): 1-7. DOI: [org/10.37105/iboa.10](https://doi.org/10.37105/iboa.10)
- [3] Al-Musawi K. A., Kottayil B. A., Potses T., Leonovich S., Kalinouskaya N., Belrauh M., Budrevich N. “Effect of calcium sulfoaluminate additive on linear deformation at different humidity and strength of cement mortars”. *Safety Engineering of Anthropogenic Objects*, No 2 (2020): 1-9. DOI: [org/10.37105/iboa.64](https://doi.org/10.37105/iboa.64)

- [4] ISO 17892-10:2018 Geotechnical investigation and testing — Laboratory testing of soil — Part 10: Direct shear tests.
- [5] ISO 17892-8:2018 Geotechnical investigation and testing — Laboratory testing of soil — Part 8: Unconsolidated undrained triaxial test.
- [6] National Aeronautics and Space Administration (NASA) (1988). Final Report - High Velocity Gas Gun.
- [7] Obwieszczenie Marszałka Sejmu Rzeczypospolitej Polskiej z dnia 15 marca 2019 r. w sprawie ogłoszenia jednolitego tekstu ustawy o dozorcze technicznym (Dz.U. 2019 poz. 667) in Polish.
- [8] Obwieszczenie Marszałka Sejmu Rzeczypospolitej Polskiej z dnia 15 maja 2020 r. w sprawie ogłoszenia jednolitego tekstu ustawy o broni i amunicji (Dz.U. 2020 poz. 955) in Polish.
- [9] PN-EN ISO 26203-1:2018-04, Metallic materials — Tensile testing at high strain rates — Part 1: Elastic-bar-type systems.
- [10] Rozporządzenie Ministra Gospodarki z dnia 21 października 2008 r. w sprawie zasadniczych wymagań dla maszyn (Dz.U. 2008 nr 199 poz. 1228) in Polish.
- [11] Rozporządzenie Ministra Nauki i Szkolnictwa Wyższego z dnia 30 października 2018 r. w sprawie sposobu zapewnienia w uczelni bezpiecznych i higienicznych warunków pracy i kształcenia (Dz. U. poz. 2090) in Polish.
- [12] Rozporządzenie Rady Ministrów z dnia 17 września 2019 r. w sprawie klasyfikacji rodzajów materiałów wybuchowych, broni, amunicji oraz wyrobów i technologii o przeznaczeniu wojskowym lub policyjnym, na których wytwarzanie lub obrót jest wymagane uzyskanie koncesji (Dz.U. 2019 poz. 1888) in Polish.
- [13] Sobczyk K., Chmielewski R. and Kruszka L. „The concept of experimental research on the behavior of sand cover material for protective shelters for civilians”. *Safety Engineering of Anthropogenic Objects*, No 2 (2020): 1-6. DOI: 10.37105/iboa.51.
- [14] Ustawa z dnia 13 czerwca 2019 r. o wykonywaniu działalności gospodarczej w zakresie wytwarzania i obrotu materiałami wybuchowymi, bronią, amunicją oraz wyrobami i technologią o przeznaczeniu wojskowym lub policyjnym (Dz.U. 2019 poz. 1214) in Polish.
- [15] Ustawa z dnia 22 sierpnia 1997 r. o ochronie osób i mienia (Dz. U. z 2020 r. poz. 838). <http://m.civil-testing-equipments.com/material-test-machine/mechanical-testing-equipment/split-hopkinson-pressure-bar-shpb.html>
- [17] <http://www.advanceinstrument.com/products/51533072.php>
- [18] <http://www.longwin.com/english/impact/split-hopkinson-pressure-bar-SHPB.html>

[19] <https://www.relinc.com/split-hopkinson-bar-kolsky-bars/>

[20] <https://www.thiot-ingenierie.com/en/gas-guns-and-other-equipment/split-hopkinson-bars-shpb-shtb/>