

Mareks MEZITIS, Janis EIDUKS, Ruslans MUHITOVŠ, Zura SANSYZBAJEVA, Roberta JANSONE, Sergejs SEMENCHUKOVŠ

## MODERNIZATION OF RAILWAY LIGHT LED DRIVER

*The proof of the positive and negative aspects of various types of optical systems that have been introduced by the railway network. Special attention is paid to special LED lamps and their power driver modernization. Modelling of the power driver circuit in the SIMULINK environment has been finished.*

### INTRODUCTION

The main signalling device in a railway transport is a signal — an optical device that signals with one or several coloured lights during the day and night. Certain signal readings transmit orders and instructions regarding a permission or prohibition for trains and manoeuvre stocks on certain sections or in a station [1].

Current trends of development of railway automated systems allow considerable expansion of the functional features of systems.

### 1. FAILURE ANALYSIS

Introduction of LED heads have been started recently, but it turned out that they have many shortcomings:

- No interchangeability. If a LED lamp fails, one must have sufficient amount of different LED lamps. It is not allowed in a railway to change the broken LED lights with lamps from different manufacturers.
- Reflection effect. Taking into account the constructive (optical) features, the optic systems of light-emitting diodes, unlike lens kits, do not have a light filter, therefore they feature the reflection effect.
- Signal axes are not parallel. LED lamps, when installed in signals, may present varied visibility, because the optical axes of signals are not parallel, a feature arising from the technological specifics.
- Flashing of engine-drivers. Flashing effect problem is especially topical during the dark period of the day.
- Aperture irregularity (Figure 1).



Fig. 1 Example of aperture irregularity

- Signal control may not be based on the light relay principle, because the flowing current will be sufficient to switch on the

light emitting diodes. Partially it can be solved by using a pulse control scheme (Figure 2). [2]

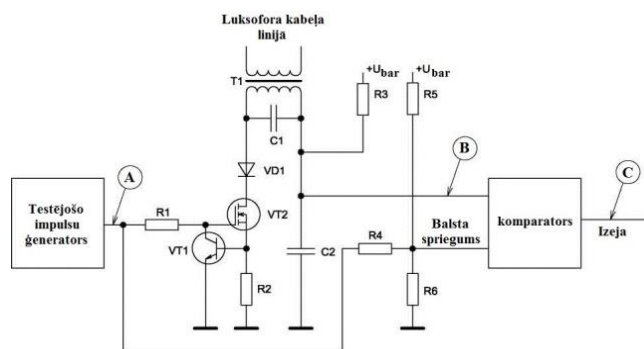

Fig. 2 Pulse control scheme of a lamp in a switched off mode

### 2. PROBLEMS OF USING LED LIGHTS

One way to solve the problem could be the use of customised LED lights allowing to implement a transition from incandescent bulbs to more modern sources of light without many adjustments.

By using white LED lamps as the source of the light, combined with the existing lenses and light filters, it will be possible to remove the reflection effect and aperture irregularity.

Electrical diagram of one of LED light versions include two separate chains of light emitting diodes, controlled through optical isolator (Figure 3).

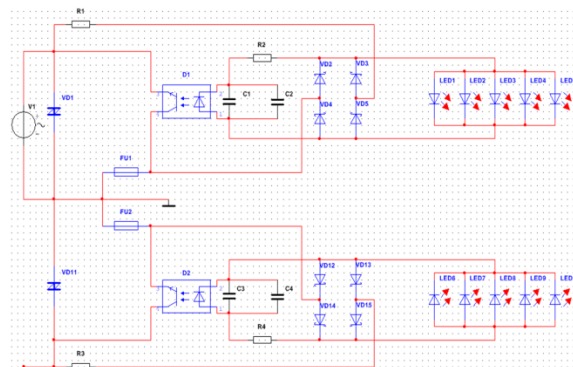

Fig. 3 Electrical diagram of a LED light

Construction of a LED light ensures geometrically accurate positioning of “filament” in the lens kit, therefore it is not necessary to

adjust the lens kit during the replacement of the lamp (currently it is a mandatory operation);

Costs of a LED lamp during equal period of operation is considerably lower than the costs from using an incandescent bulb;

Shape of T-radiator in comparison to an incandescent bulb allows to obtain more extensive vertical scatter diagram of light intensity, at a distance close to the visualisation, i.e. approximately 20 m, which is an advantage of this construction if compared to an incandescent bulb (Figure 4; [3])

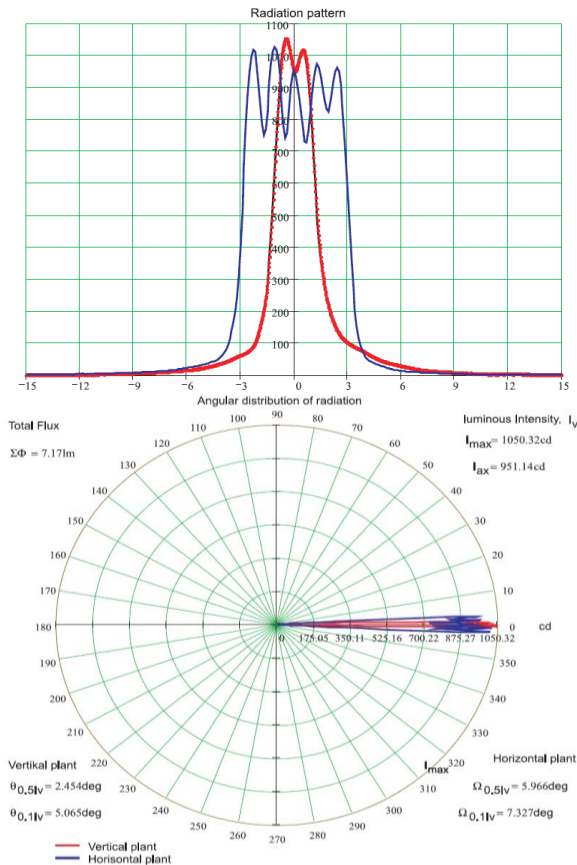

**Fig. 4** Photometric parameters of a LED light and angular distribution of signal's light intensity

The offered version of LED light diagram does not include the functionality of performance of the optoelectronic relay. During the LED light test the following effect will be established in the railway signal. MPC system sends a test impulse to the signal's lamp once in five minutes. In this case, when testing the lamp with controllers, a voltage conducted from the signal transformer to the lamp falls directly on the light emitting diodes. This action causes the signal blink for a short while.

The test operation showed that the control of LED light implemented by optoelectronic relay is important for the railway traffic safety.

### 3. MODELLING OF LED LIGHTS POWER DRIVER

A LED light must be equipped with a back-up radiation elements featuring parameters equal to the basic element parameters. An electric circuit of the basic radiating elements functions the same way as the electric circuit of the back-up radiating elements.

The basic elements of the electrical circuit of a bulb: light-emitting diodes LED1 - LED5 and optoelectronic relays D1...D3. Remaining elements of the circuit ensure their functions with opera-

tional parameters. TVS diode VD1 protects the circuit elements from pulse overvoltage (Figure 5).

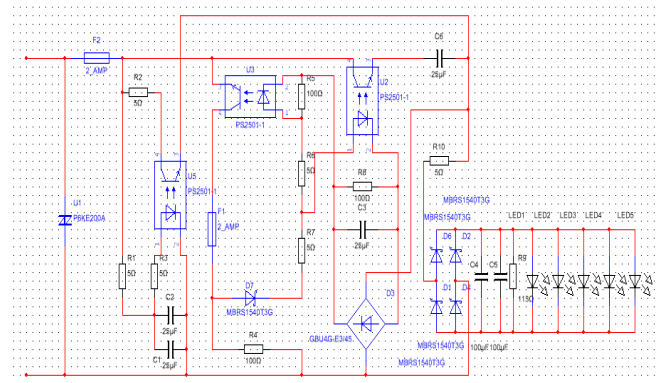

**Fig.5** Modified diagram of a LED light bulb

The light bulb operates in this way:

1. In absence of the voltage corresponding to signal reading on power outputs of the light bulb, the line is being shunted with normally closed contacts 3-4 of the optoelectronic relay D2 and resistor R4. It prevents LED lamp from emitting the light through cable conductor under the influence of mutually induced alternating current EDS when the signal is located far from the power supply.
2. By feeding the voltage from the alternate current source, the signal's voltage through contacts 3-4 of the optoelectronic relay D2, FU2, VD2, R7 causes contacts 3-4 of the optoelectronic relay D3 to switch to a closed mode and to cut in the power rectifier bridge VD3-VD6 of the light-emitting diodes VD-7...VD11. Presence of the current in a circuit VDS1 - IR diode D2 - R6 - IR diode D3 - VDS1 ensures switching of the optoelectronic relay D2 to an open mode and disconnecting of the shunting resistor R4. The light bulb operates in a standard mode (Figure 6).

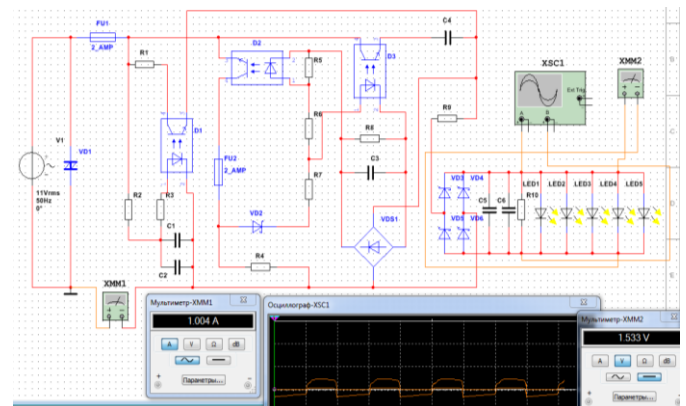

**Fig. 6** Modelling of LED light operation in SIMULINK.

D2 and D3 commutation elements can be switched only if they are in a working condition. In case of a disconnection fault of the optoelectronic relay D2 the absence of the current in VD2 will not permit connecting D3 light emitting diodes to power circuit of IR diodes.

If the current is present in R4, it will cause protection fault in FU1 or FU2. D3 fault will cause the same result. This ensures the control over mutually working condition of relays D2 and D3.

Feeding a supply voltage from direct current source will switch optoelectronic relays to the following modes;

- D1 - connected;
- D2 - disconnected;

– D3 - connected.

The supply voltage through D1 outputs 3-4 is fed to the light emitting diodes and arrives at the capacitor C4 that dampens the direct current flow.

If the power is disconnected the voltage drops in the output of the diode bridge VDS1 due to overcurrent created by the light emitting diodes. Current reduction in the circuit VDS1 - IR diode D2 - R6 - IR diode D3 - VDS1 will switch the optoelectronic relays: D3 - disconnected, D2 - connected. The light bulb is switched off.

High speed of switching of the optoelectronic relays ensures a stable operation in the blinking mode without reducing the light bulb's operational resource.

D1 - disconnection fault. When a direct current supply voltage is fed, the light emitting elements glow. It is established by SCB interface devices, because there is no current in the light bulb's circuit.

D1 - short circuit fault. Light emitting diodes are fed by bypassing the damping capacitor C4 that increases the current in the circuit up to the values that are sufficient for fuse FU1 to actuate.

D2 - disconnection fault. There is no current running through VD2. Commutation group of the optoelectronic relay D3 switches, light emitting diodes are disconnected. In this case there is no current in the light bulb's circuit either from the induced EDS or the supplied voltage. SCB interface devices will establish a disconnection fault, because the circuit will have no current.

D2 - short circuit fault. In case of a switched off signal reading standard shunting of the line must be established. Feeding a voltage that is appropriate for the signal condition will create current in the light emitting diode circuit through contacts 3-4 of the optoelectronic relay, as well as through the shunting resistor R4. Fuse FU1 actuates. The light bulb switches on.

D3 - disconnection fault. No glowing. Commutation element of the optoelectronic relay D2 does not switch to a disconnected mode, because there is no voltage on the diode bridge VDS1. Fuse FU2 actuates. There is no current in the light bulb circuit. Protection fault.

D3 - short circuit fault. Shunting of the line through D2 contacts 3-4, EDS induced by FU2, R4 are reduced to a value which does not cause light emitting diodes to glow.

Any element circuit VDS1 - IR diode D2 - R6 - IR diode D3 - VDS1 will cause a fault of optoelectronic relays D2 and D3 during

which they will be also in fault mode, that corresponds to the initial condition of the basic elements — protection fault. During the fault of VD2 and R7 the relay D3 will not switch to connect and it will cause a protection fault that will be detected by SCB interface, because the current will not flow in the light bulb's circuit. Thus if analysing the light bulb's faults it is not necessary to analyse the faults of these elements in particular.

## CONCLUSION

The article described an opportunity to use modified LED lamps as the source of the light in the railway signals. The discussed diagram of the electric light emitting diodes served as the basis for elaboration of modified power drive module in Multisim software. This software was used to model operation of a light bulb and possible faults during its use.

## REFERENCES

1. Mezītis M., Podsošonnaja O. Vilcienu kustības intervālu regulēšanas sistēmas (releju). Mācību līdzeklis. – Rīga, RTU, 2006.
2. «Автоматика, связь, информатика» – ежемесячный научно-теоретический и производственно технический журнал. 11 - 2013
3. Никифоров С.Г., Абрамов В.С., Иванов А.А. Светодиодная лампа для железнодорожных светофоров. Полупроводниковая светотехника. – 2010. №. 3
4. Вентцель Е.С. Теория вероятностей. М.: Наука, 1969.

Authors

**Mareks Mezitis** - marek@dzt.rtu.lv,

**Janis Eiduals** - j\_eiduals@hotmail.com

**Ruslans Muhitovs** - muhitovs@gmail.com

**Zura Sansyrbajeva** - zura\_astana@mail.ru,

**Roberta Jansone** - robertamartajansone@gmail.com,

**Sergejs Semenchukovs**

JEL: L92 DOI: 10.24136/atest.2018.141

Data zgłoszenia: 2018.05.23 Data akceptacji: 2018.06.15