

High temperature wettability and reactivity between molten Mg in contact with Ni substrate

Wysokotemperaturowe badania zwilżalności i reaktywności ciekłego Mg w kontakcie z podłożem Ni

Artur Kudyba^{1*}, Natalia Sobczak^{1,2}, Patrycja Turalska¹, Grzegorz Bruzda¹, Advenit Makaya³, Laurent Pambaguian³

¹Foundry Research Institute, ul. Zakopianska 73, 30-418 Krakow, Poland

²Institute of Precision Mechanics, ul. Duchnicka 3, 01-796 Warsaw, Poland

³ESTEC, European Space Agency, 2200 AG Noordwijk, The Netherlands

¹Institut Odlewnictwa, ul. Zakopiańska 73, 30-418 Kraków, Polska

²Institut Mechaniki Precyzyjnej, ul. Duchnicka 3, 01-796 Warszawa, Polska

³ESTEC, European Space Agency, 2200 AG Noordwijk, Holandia

*Corresponding author: artur.kudyba@iod.krakow.pl

Received: 18.05.2018. Accepted in revised form: 30.06.2018.

© 2018 Instytut Odlewnictwa. All rights reserved.

DOI: 10.7356/iod.2018.05

Abstract

The paper focuses on the experimental investigation of high temperature wetting behaviour of liquid pure Mg during a contact heating on Ni substrate by the sessile drop method. High temperature wettability test was performed by the classical sessile drop method at $T = 700^\circ\text{C}$ for $t = 300$ s, under flowing Ar 99.999% atmosphere, by using the equipment and testing procedures that have been developed by the Foundry Research Institute. In order to suppress effects of heating and cooling histories on wetting and spreading behaviours, Mg/Ni couple was introduced inside a metallic heater already preheated up to the test temperature, while after the wettability test, it was immediately removed to the cold part of the chamber. During the wettability test, images of the couple were recorded by high-resolution high-speed CCD camera. It was observed, that the wetting phenomenon ($\theta \leq 90^\circ$) takes place immediately after melting of Mg sample. The Mg/Ni system shows a good wetting at $T = 700^\circ\text{C}$ after $t = 300$ s forming the final contact angle of 18° .

Keywords: sessile drop, wettability, reactivity, metal matrix composites (MMC)

Streszczenie

Praca prezentuje wyniki badań wysokotemperaturowego oddziaływania ciekłego Mg w kontakcie z podłożem Ni podczas wspólnego nagrzewania badanej pary materiałów. Wysokotemperaturowe badania zwilżalności przeprowadzono klasyczną metodą kropli leżącej w temperaturze $T = 700^\circ\text{C}$ i czasie $t = 300$ s w gazie przepływowym Ar 99,999%. Do badań zastosowano aparaturę i procedury badawcze opracowane w Instytucie Odlewnictwa. W celu eliminacji wpływu historii nagrzewania i chłodzenia na zwilżalność i rozplątliwość, badany układ Mg/Ni wprowadzono do gorącej części komory badawczej nagrzanej do temperatury badań. Po badaniach zwilżalności badaną parę materiałów natychmiast wprowadzono do zimnej części komory badawczej. Podczas badań zwilżalności stosowano ciągłą rejestrację obrazu ba-

danej pary materiałów za pomocą wysokorozdzielczej kamery cyfrowej CCD. Zaobserwowano, że zjawisko zwilżania ($\theta \leq 90^\circ$) zachodzi natychmiast po stopieniu próbki czystego Mg. Układ Mg /Ni wykazuje bardzo dobrą zwilżalność w temperaturze $T = 700^\circ\text{C}$ po $t = 300\text{ s}$, a końcowa wartość kąta zwilżania wynosi 18° .

Słowa kluczowe: kropla leżąca, zwilżalność, reaktywność, kompozyty o osnowie metalicznej (MMC)

1. Introduction

In current years, a growing interest in experimental measurements of thermophysical, physicochemical and technological properties of liquid Mg and Mg-based alloys, is observed in both basic and applied research areas [1–5]. Furthermore, a clarification of interphase phenomena taking place at high temperature processing and exploitation of these materials, has recently gathered a lot of attention. Mg-based alloys, and especially Mg-based composites, are attractive candidates for many structural applications mainly due to their high specific strength and stiffness as well as a very good wear resistance [6]. The light-weight and high strength-to-weight Mg alloy matrix composites offer incredible advantages in the aerospace use, where high strength at elevated service temperatures and environmental resistance should be combined with a light weight of components. Besides space applications, light-weight materials are extremely desired for various structural and functional applications in automotive, military, medicine and others industrial branches. Among the structural light-weight materials used in construction of current vehicles and propulsion systems for air and space, magnesium alloys have the lowest density. In order to ensure a high quality of fabricated composites, it is necessary to experimentally determine a course of

interface phenomena taking place between molten Mg (a matrix) and various reinforcements.

This paper reports the results of high temperature wetting behaviour of liquid pure Mg during a contact heating on Ni substrate at $T = 700^\circ\text{C}$ and $t = 300\text{ s}$, by the sessile drop method.

2. Experimental procedure

The magnesium piece of 99.9 wt. % purity and cube shape with dimensions of 4 mm × 4 mm (Fig. 1a) and the nickel substrate of 99.8 wt. % purity (Stalchem, Poland) in the form of a plate having a diameter of 17 mm and a thickness of 5 mm (Fig. 1b), was used for a high temperature wettability test. Directly prior to the test, the Ni substrate surface was grounded by using SiC papers with maximum gradation of 1000, and then polished to a roughness of $Ra \approx 50\text{ nm}$ on fine polishing cloths using diamond paste with a grain size of 0.25 μm . The polished Ni substrate and Mg metal was ultrasonically cleaned in $\text{C}_3\text{H}_8\text{O}$ alcohol (isopropanol) for 5 minutes using the Polsonic SONIC 2 device. The prepared substrate material was used for the high temperature liquid magnesium wettability test.

The wettability and reactivity test was performed by a classical sessile drop method coupled with contact heating procedure (CH) [7], schematically demonstrated in Figure 2, at $T = 700^\circ\text{C}$ for $t = 300\text{ s}$ under flowing a high purity protective atmosphere (Ar 99.999%).

The research was done by using on equipment that have been developed by the Foundry Research Institute [8]. The schematic drawing and description are shown in Figure 3.

During the test, a metal sample Mg was placed on a substrate and the Mg/Ni couple was located on experimental table (support) in a cold part of the vacuum chamber. After evacuation of gases and reaching

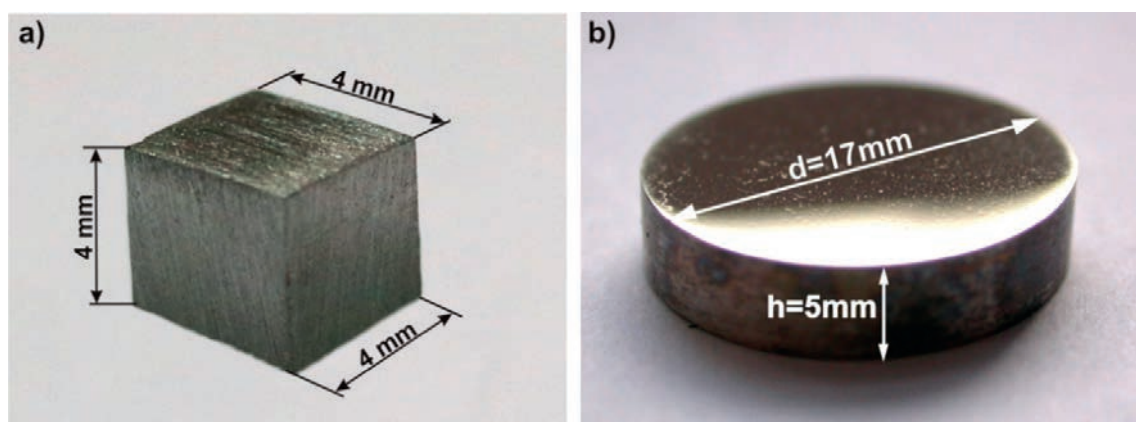

Fig. 1. Material used for high temperature wettability test: a) Mg metal of 99.9 wt. % purity, b) Ni substrate of 99.8 wt. % purity

Rys. 1. Materiał zastosowany do wysokotemperaturowych badań zwilżalności: a) Mg o czystości 99,9% wag., b) podłoże Ni o czystości 99,8% wag.

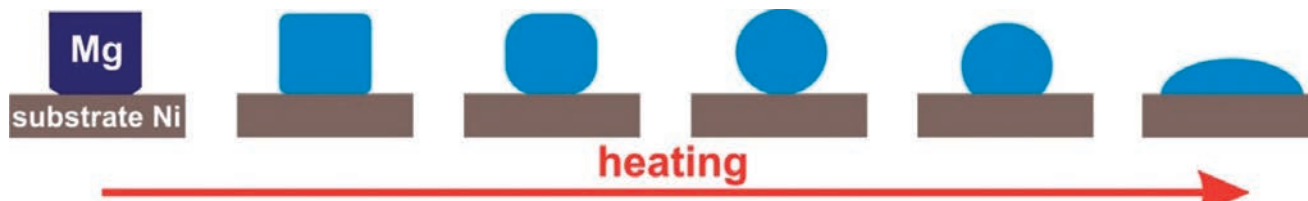

Fig. 2. The contact heating (CH) testing procedure of the classical sessile drop method [8]

Rys. 2. Procedura wspólnego nagrzewania badanej pary materiałów (CH) w klasycznej metodzie kropli leżącej [8]

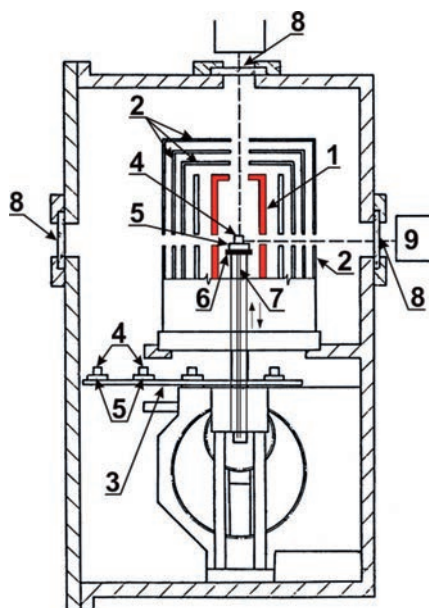

Fig. 3. A schematic presentation of the wettability testing equipment by the sessile drop method combined with CH procedure: 1 – Mo heater, 2 – Mo screens, 3 – rotating loading table, 4 – alloy, 5 – substrate, 6 – experimental table with up and down movement, 7 – thermocouple, 8 – observation window, 9 – high-speed CCD camera [8]

Rys. 3. Schemat stanowiska do badań zwilżalności klasyczną metodą kropli leżącej w połączeniu z procedurą CH: 1 – grzejnik Mo, 2 – ekrany Mo, 3 – obrotowa tarcza magazynowania próbek, 4 – stop, 5 – podłoże, 6 – stolik badawczy z możliwością regulacji pozycji góra–dół, 7 – termopara, 8 – okno obserwacyjne, 9 – wysokorozdzielcza kamera CCD [8]

a pressure of $p = 10^{-5}$ mbar, the chamber was filled with Ar (flowing gas) up to a small overpressure and then heating was started using molybdenum heater of tube-like shape. When the test temperature of 700°C was reached, the Mg/Ni couple was introduced inside the heater. During the test, continuous imaging of Mg/Ni system was recorded using high-speed and high-resolution digital camera Microtron 1310 with a rate of 10–100 fps (depending on the stage of the test). After 300 s of the test, a couple was removed from the heater to a cold part of the vacuum chamber. The collected images obtained were undergo computer image analysis using specialized software ASTRAView©, developed by IENI-CNR, Genua, Italy [9]. The software was used to calculate contact angle (θ) and wettability kinetics $\theta = f(t)$ of the investigated materials.

During the test cycle (from room temperature, heating up process) some parameters were recorded continuously:

1. pressure in the vacuum chamber,
2. temperature on the test table,
3. heater's temperature,
4. geometric parameters of drops.

The produced sessile drop couple was then subjected to a detailed structural characterization by using Hitachi TM3000 scanning electron microscope coupled with the EDS (Energy Dispersive Spectroscopy) analyser for chemical analysis.

3. Results

Figure 4 illustrates the images of the most characteristic moments during the high temperature wettability test of the Mg/Ni couples, recorded by the digital camera at

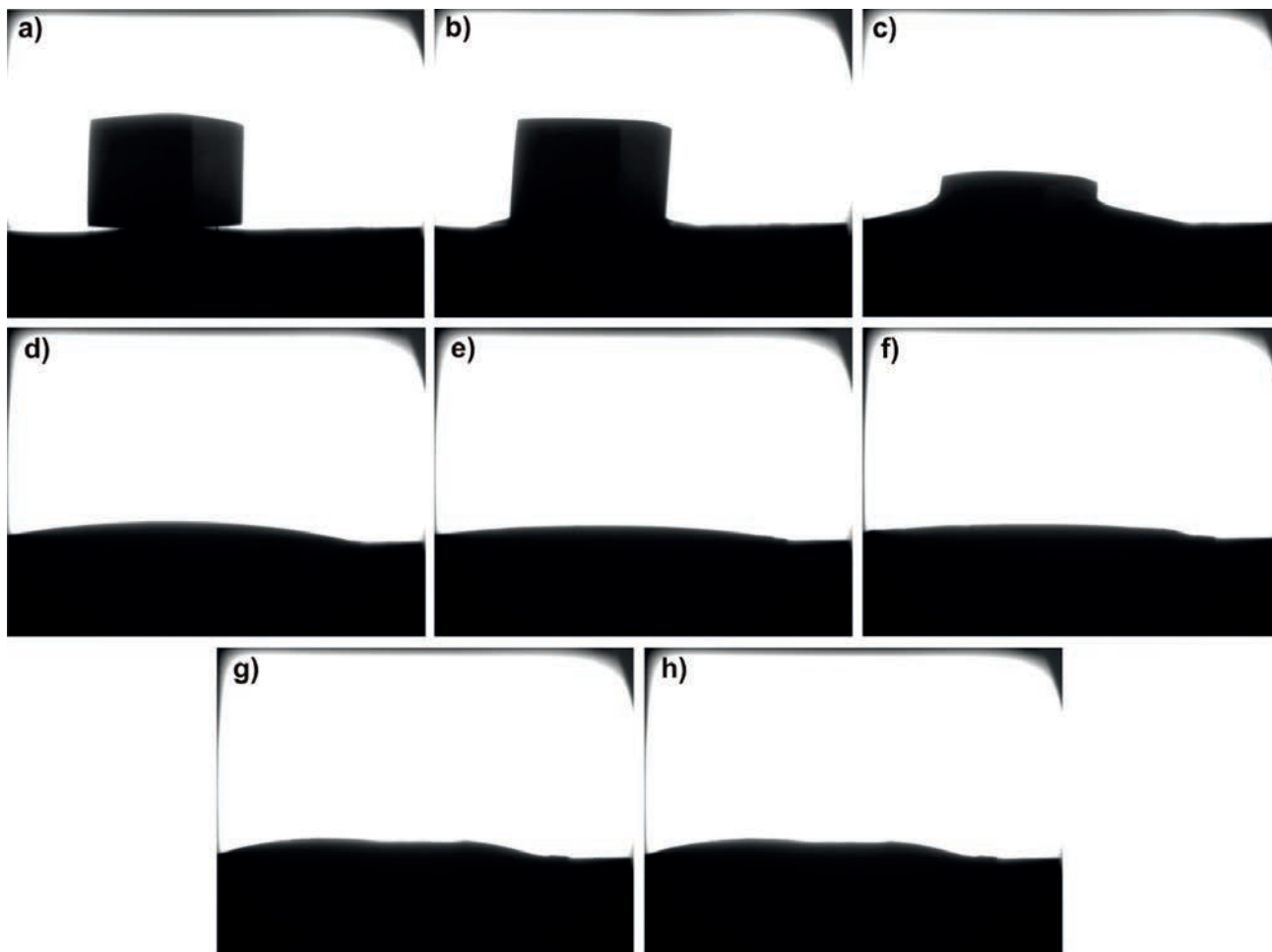

Fig. 4. Images recorded by the CCD camera during the test of Mg/Ni at $T = 700^{\circ}\text{C}$ for $t = 300$ s, under flowing Ar 99.999% atmosphere (test #2656): a) the couple before test at $T = 25^{\circ}\text{C}$, b) beginning of melting at $T = 610^{\circ}\text{C}$, c) melting at $T = 630^{\circ}\text{C}$, d) the end of melting at $T = 650^{\circ}\text{C}$, e) the beginning of the test at $T = 700^{\circ}\text{C}$, $t = 0$ s, f) $T = 700^{\circ}\text{C}$, $t = 150$ s, g) the end of the test at $T = 700^{\circ}\text{C}$, $t = 300$ s, h) the end of the experiment at $T = 670^{\circ}\text{C}$

Rys. 4. Obrazy zarejestrowane kamerą CCD podczas badań zwilżalności Mg/Ni w temperaturze $T = 700^{\circ}\text{C}$ dla $t = 300$ s, w gazie przepływowym Ar 99,999% (test #2656): a) para badanych materiałów przed testem w $T = 25^{\circ}\text{C}$, b) początek topienia w temperaturze $T = 610^{\circ}\text{C}$, c) topienie w $T = 630^{\circ}\text{C}$, d) koniec topienia w $T = 650^{\circ}\text{C}$, e) początek testu w $T = 700^{\circ}\text{C}$, $t = 0$ s, f) $T = 700^{\circ}\text{C}$, $t = 150$ s, g) koniec testu w $T = 700^{\circ}\text{C}$, $t = 300$ s, h) koniec badań w $T = 670^{\circ}\text{C}$

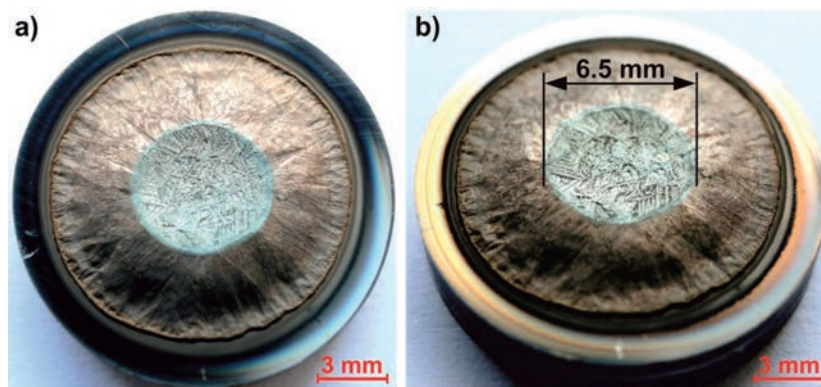

Fig. 5. Images of sample #2656 Mg/Ni after the high temperature wettability test at $T = 700^{\circ}\text{C}$, $t = 300$ s: a) the top view, b) the top view from another perspective

Rys. 5. Zdjęcia próbki Mg/Ni (#2656) po wysokotemperaturowych badaniach zwilżalności w $T = 700^{\circ}\text{C}$, $t = 300$ s: a) widok z góry, b) widok z góry z innej perspektywy

50 frames per second. The images of the Mg/Ni couple recorded in real-time observations were subsequently used for the investigation of wetting behavior of the couple.

The melting of Mg piece placed on Ni substrate (Fig. 4a) started in the contacting area, at $T = 610^{\circ}\text{C}$ (Fig. 4b), i.e. before reaching the melting point of Mg (650°C). With a further increase of the testing temperature, the Mg piece changed its shape and it was spread on the Ni surface (Figs. 4c–d). After reaching 700°C , the Mg/Ni couple was held for 300 s (Figs. 4e–g), and the change of geometry and spreading, were observed.

Figure 5 shows the images of samples after the test. The regular round shape of the Mg drop solidified on the Ni substrate is observed.

The solidified Mg drop covers almost whole Ni surface (Fig. 5a), what reflects a very good wettability and spreading of molten Mg on the Ni substrate. However, it is also observed that the tip of the Mg drop has a bright, concave shape with a diameter of ~ 6.5 mm. The concave interior exhibits a fine needle-like morphology (Fig. 5b). What should be noted, the sunken shape of the upper part of the drop revealed upon the inspection of solidified drop was not visible during the test at 700°C for $t = 300$ s (Fig. 4e–g). Therefore, it is reasonable to assume that it was formed due to the shrinkage of metal upon the solidification stage.

The results of the high temperature wettability test of Mg/Ni system are summarized in Table 1. The contact angle values (θ) calculated for 60 s intervals show its variation between 19 and 7° (after 60 and 180 s of the test, respectively). Nevertheless, the final value of the contact angle was equal to 18° (i.e. $<90^{\circ}$) what confirms a very good wettability in the Mg/Ni system.

Figure 6 shows the wetting kinetics curve (the θ vs. time plots) of the liquid pure Mg on Ni substrate, as recorded during the high temperature wettability test at temperature of 700°C for 300 s.

The contact angle measurements (Table 1) and the analysis of wetting kinetics curve demonstrated very good wetting and spreading of liquid pure Mg on Ni substrate (Fig. 6). The excessive spreading of the drop means that after 25 seconds of the test the drop was partially obscured by heating screens. Consequently, further measurements for both angles became impossible and that is why only one angle was determined (only right angle). The pure Mg drop, formed a close contact and a chemical interaction with the Ni substrate. This phenomenon has a direct impact on the kinetics of the contact angle in the system, causing the wetting ($\theta < 90^{\circ}$) and spreading of liquid Mg drop. The good wetting accompanied with a very fast spreading took place immediately after the melting of Mg piece (melting point of 650°C), forming at $T = 700^{\circ}\text{C}$ after $t = 300$ s the final contact angle of 18° . During the heating to the test temperature of 700°C , the contact angle on the pure Ni substrate increased up to 18° and it was

Table 1. The results of the high temperature wettability test of Mg/Ni system, at $T = 700^{\circ}\text{C}$ for $t = 300$ s, under flowing Ar 99.999% atmosphere

Tabela 1. Wyniki wysokotemperaturowych badań zwilżalności układu Mg/Ni, w temperaturze $T = 700^{\circ}\text{C}$ dla $t = 300$ s w gazie przepływowym Ar 99,999%

Metal/ Metal	Substrate/ Podłoże	$\theta, ^{\circ}$						after cooling/ na zimno
		0 s	60 s	120 s	180 s	240 s	300 s	
Mg	Ni	16	19	10	7	16	18	7

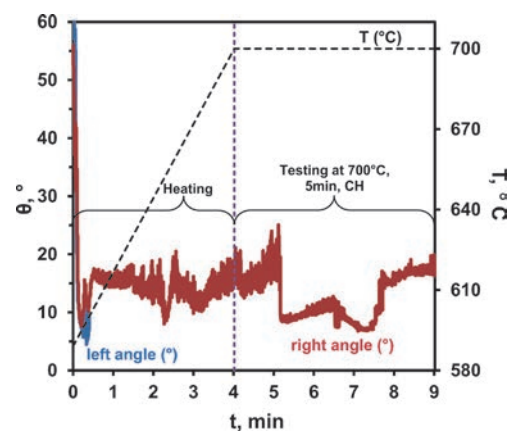

Fig. 6. Wetting kinetics curve (contact angle vs. time) of liquid pure Mg on Ni substrate at 700°C for $t = 300$ s

Rys. 6. Krzywa kinetyki zwilżania (wartość kąta zwilżania w funkcji czasu) ciekłego Mg na podłożu Ni w temperaturze 700°C dla $t = 300$ s

varying with time during holding at 700°C . The minimum value of 7° and maximum value of 25° (Fig. 6) were recorded. After 300 seconds, the contact angle was 18° and upon the cooling, it decreased again to $\theta = 7^{\circ}$. This difference most probably originates from the shrinkage upon the magnesium solidification in the case of the Mg/Ni system.

The results of structural characterization of cross-sectioned solidified couple, are shown in Figure 7. The SEM examinations (at the magnification of $30\times$) confirmed the spreading of molten Mg drop at 700°C and the formation of concave on its top. At a higher magnification ($500\times$), two phases located on the drop side may be distinguished (Fig. 7b). The dark grey phase shows a morphology of large crystal with a well-developed surface. Between these crystals, the other phase with a differentiated structure, is observed (Fig. 7c). The results of local chemical composition analyses in these sites revealed that the dark grey phase is composed of 57.8 at. % Mg and 42.2 at. % Ni (Fig. 7b, P.1), while the content of Ni and Mg in the other one is 69.0 at. % and 31.0 at. %, respectively (Fig. 7b, P.2).

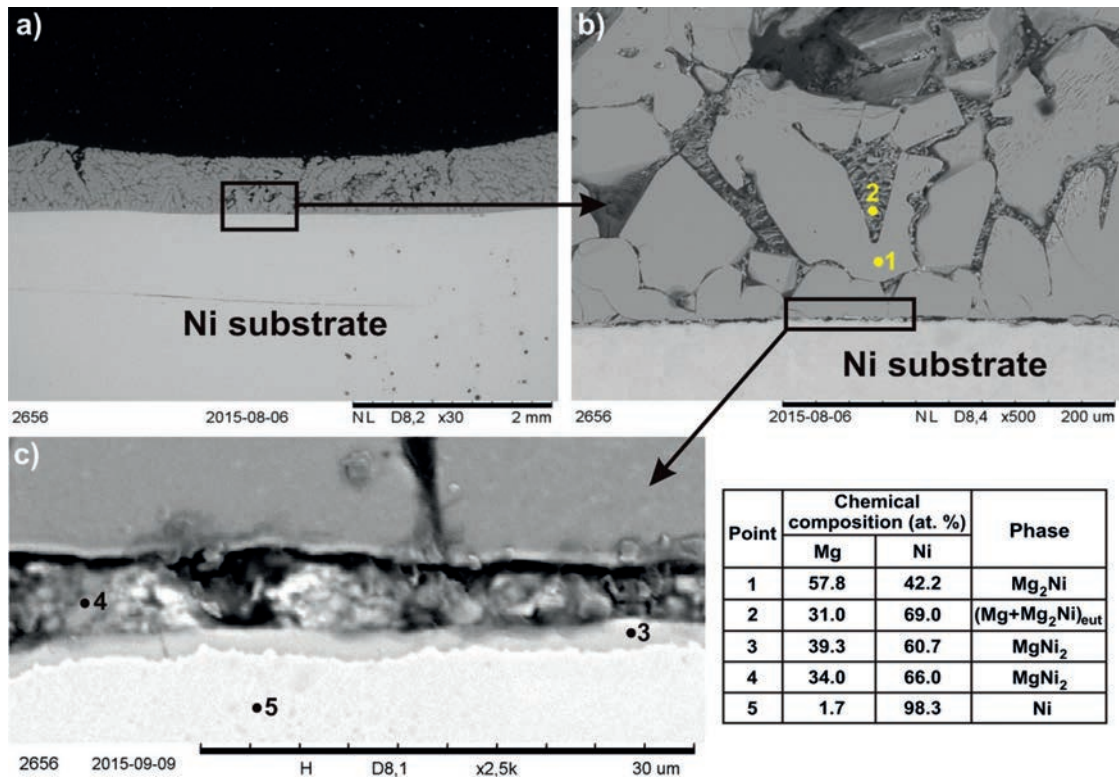

Fig. 7. Structural characterization of cross-sectioned Mg/Ni solidified couple: a) magnification 30×, b) magnification 500×, c) chemical analysis of phases formed during high temperature interaction

Rys. 7. Charakterystyka strukturalna przekroju poprzecznego badanej pary materiałów Mg/Ni: a) powiększenie 30×, b) powiększenie 500×, c) analiza składu chemicznego faz utworzonych podczas oddziaływania wysokotemperaturowego

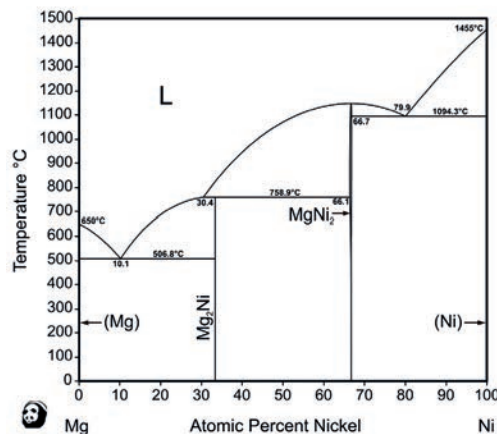

Fig. 8. Mg-Ni phase diagram [10]

Rys. 8. Układ równowagi fazowej Mg-Ni [10]

Furthermore, a thin layer having the chemical composition of 60.7 at. % Ni and 39.3 at. % Mg was observed at the interface on the substrate side (Fig. 7c, P.3). The results of EDS analyses carried out in the gap located between the drop and substrate revealed a presence of participates with corresponding chemical composition of 66.0 at. % Ni and 34.0 at. % Mg (Fig. 7c, P.4). Additionally, small amounts of Mg (up to 1.7 at. %), were also detected in the initially pure Ni substrate (Fig. 7c,

P.4). On the other hand, the Mg drop contains large amount of Ni coming from the substrate (Fig. 7, P.1-4). The results clearly point towards a mutual dissolution of the contacting drop/substrate couple.

Based on the results of the EDS evaluations and the Mg-Ni phase diagram (Fig. 8), it is concluded that the chemical composition of large crystals corresponds to Mg₂Ni phase (Fig. 7b, P.1) that could be formed on the drop side at testing temperature. Moreover, the other

phase (Fig. 7b, P.2) surrounding the large crystals could be recognized as $(\text{Mg} + \text{Mg}_2\text{Ni})_{\text{eut}}$ ($T_{\text{eut}} = 508^\circ\text{C}$). Finally, the chemical composition of the interfacial phase (Fig. 7c, P.3) on the substrate side might correspond to MgNi_2 . Based on the Mg-Ni phase diagram (Fig. 8), the reactive wetting between liquid Mg and Ni substrate is possible through two mechanisms, i.e. a dissolutive wetting and through the formation of interfacial reaction products, most probably MgNi_2 phase.

4. Summary

1. The contact angle measurements and the analysis of wetting kinetics have demonstrated very good wetting of liquid pure Mg on Ni substrate.
2. The wetting phenomenon ($\theta \leq 90^\circ$) in Mg/Ni system takes place immediately after melting of Mg sample (melting point of 650°C).
3. During the heating to the test temperature of 700°C , the contact angle on Ni substrate was varying with time ($\theta = 7-25^\circ$) during the holding at 700°C . After 300 seconds the contact angle was 18° and upon the cooling it decreased again to $\theta = 7^\circ$.
4. Wettability in the Mg/Ni system is reactive. The reactive wetting between liquid Mg and Ni substrate is possible through two mechanisms, i.e. 1) the formation of new reaction product at the interface (most probably the MgNi_2 phase) and 2) the dissolution of Ni in liquid Mg. It is believed that the first mechanism resulting in the formation of wettable interfacial reaction product is the leading one.
5. Ni is a good candidate for application as technological coating in synthesis of cast Mg-matrix composites for improvement of wetting between the liquid Mg matrix and a ceramic reinforcement.

Acknowledgements

The work has been carried out within research project "New generation light-weight materials for advanced space applications" financed by the European Space Agency, under Contract No. 4000109468/13/NL/Cbi.

References

1. Contreras A., C.A. Leon, R.A.L. Drew, E. Bedolla. 2003. „Wettability and spreading kinetics of Al and Mg on TiC”. *Scripta Materialia* 48 (12) : 1625–1630.
2. Contreras A., V.H. López, E. Bedolla. 2004. „Mg/TiC composites manufactured by pressureless melt infiltration”. *Scripta Materialia* 51 (3): 249–253.
3. Contreras A., E. Bedolla, R. Pérez. 2004. „Interfacial phenomena in wettability of TiC by Al–Mg alloys”. *Acta Materialia* 52 (4) : 985–994.
4. Fujii H., S. Izutani, T. Matsumoto, S. Kiguchi, K. Nogi. 2006. „Evaluation of unusual change in contact angle between MgO and molten magnesium”. *Materials Science and Engineering: A* 417 (1–2) : 99–103.
5. Zhang D., P. Shen, L. Shi, Q. Jiang. 2011. „Wetting of B_4C , TiC and graphite substrates by molten Mg”. *Materials Chemistry and Physics* 130 (1–2) : 665–671.
6. Braszczyńska K.N., A. Zyska, J. Braszczyński. 2003. „Ocena przydatności osnowy z różnych stopów magnezu w kompozycie umacnianym cząstkami SiC”. *Kompozyty* 3 (8) : 353–359.
7. Sobczak N., M. Singh, R. Asthana. 2005. „High-temperature wettability measurements in metal/ceramic systems – Some methodological issues”. *Current Opinion in Solid State and Materials Science* 9 (4–5) : 241–253.
8. Galon J., N. Sobczak, R. Ryglicki. 1988. Patent of Poland No. PL 50513.
9. *ASTRA Reference Book*. 2007. IENI-CNR Italy, Report.
10. Calculated using PANDAT© software.

