

Using the phased array antenna to increase geometric size of the interrogation zone in a UHF RFID system

PIOTR JANKOWSKI-MIHUŁOWICZ, DAMIAN KAWALEC,
MARIUSZ WĘGLARSKI, WOJCIECH LICHŃ

*Department of Electronic and Telecommunications Systems
Rzeszów University of Technology
W. Pola 2, 35-959 Rzeszów, Poland
e-mail: pjanko/wmar/damkaw@prz.edu.pl*

(Received: 30.09.2016, revised: 18.02.2017)

Abstract: An attempt to increase the geometric size of the interrogation zone in UHF RFID systems with a phased array antenna is presented in this paper. The interrogation zone should be as large as possible. However, energy can be transferred to transponders only to a limited distance. The greatest flexibility in developing RFID applications and shaping the interrogation zone can be achieved using a phased array antenna. The perceived issues have been effectively dealt with and the solution has been proposed on the basis of an elaborated model. Conducted studies have been used to develop a software tool in the Mathcad environment. The research results are analyzed in detail for different system configurations and can be implemented in practical projects to be developed in cooperation with the industry.

Key words: phased array antenna, anti-collision identification, interrogation zone, RFID

1. Introduction

A typical RFID system consists of a read/write device (RWD), its antenna and at least one transponder that is intended for marking an object [1, 22]. The RWD is connected to a computer comprising the management center, whereas the electronic transponders are used for marking objects in various areas of people's economical and social activities (e.g. science, industry, medicine, logistics, consumer market and many other fields [2-4]). Communication in this system is done with one transponder or simultaneously with multiple transponders (single or anti-collision system respectively) that can also be found in a static or dynamic state (moving objects).

A radiative coupled RFID system in the UHF band – depending on the region of the world – typically operates in the frequency range of 860 MHz to 960 MHz. Data is sent from the transponder to the RWD using backscatter communication. This process is followed by a partial reflection of the carrier wave toward read/write devices, using modulation, which is imple-

mented by using impedance changes swept by the chip transponder. The communications principles are implemented in the protocol denoted Electronic Product Code (EPC) Class 1 Gen 2 [5], where the latest version is currently standardized in ISO/IEC 18000-63 (formerly ISO/IEC 18000-6).

The UHF RFID systems operate by utilizing a far-field zone where vectors of electric and magnetic field strength are perpendicular both to each other and to the direction in which the wave propagates. The wave locally can be considered as plane. The radiated electromagnetic wave of power density S is an energy carrier supplying passive or semi-passive transponders (Fig. 1). The carrier wave of frequency f_0 is used to transmit energy by matched antennas, but it should be noticed that the impedance matching of a transmitter and a receiver known from the classical theory is valid only for the read/write device and its antenna (50Ω).

The communication process can be activated only when transponders are in the interrogation zone (IZ). It means that the operational capability of RFID systems is characterized by the interrogation zone. This parameter is defined by the limitations of energy and communication activity with regards to all parts of a system arrangement. It also determines and comprehensively describes possibilities of an RFID system application in desirable automated processes.

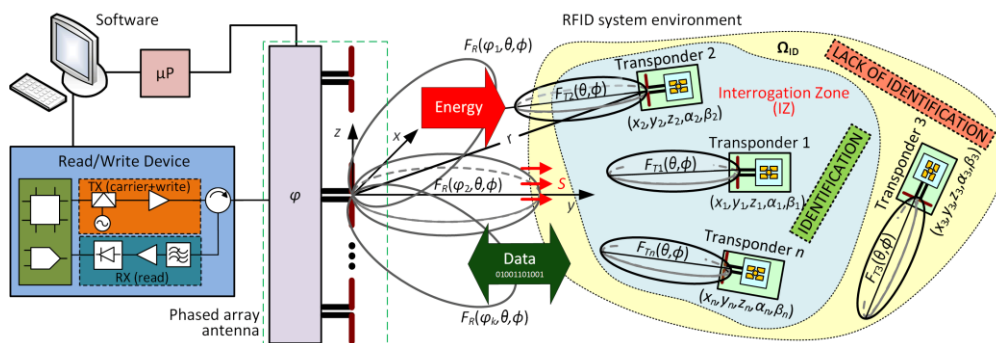

Fig. 1. Anti-collision UHF RFID system with phased array antenna

From the users point of view, the interrogation zone should be as large as possible for the correct recognition of differently placed objects. The primary way to do this without changing the transponder and its location is, for example, to increase the power delivered to the long range (LR) RWD antenna [6]. However, it should be noted that in the UHF band systems, energy conditions are limited by European standardization: ETSI EN 302 208 – 2 W ERP in the frequency band from 865.6-867.6 MHz, or American: FCC Part 15.247 (1 W of transmitter output power with maximal gain of 6 dBi) – 4 W EIRP in the frequency band 902-928 MHz [1]. Increasing the size of the interrogation zone can also be obtained through the multiplication of RWD systems and their antennas [7], but this significantly increases the cost of LR systems. Considerable flexibility in shaping the interrogation zone can be obtained by using a multiplexing array antenna [7, 8]. In this case the complicated, specific arrangement of spatially placed read/write device array antennas should always be examined [9-12].

In this respect, it is interesting to examine the possibility of electronic control characteristic of the main beam radiation pattern in a phased array antennas [21]. Despite the fact that for a long time this function was used only in military applications, now increasingly, it can also be found in civilian applications such as when identifying objects based on the shapes of their echoes in radio astronomy or weather forecasting [13]. In this context, new opportunities may be sought for the use of the phase antenna arrays [14-16].

Bearing in mind the limitations of available energy, the article proposes the idea of enhancing directional EM field energy radiation by a phased array antenna RWD, which should enable a predictable increase in the volume of geometric dimensions of the interrogation zone in an anti-collision UHF band RFID system. It should be noted that a lot of issues in this regard remain unresolved at the current stage of contemporary knowledge. For example, only the maximal distance (RFID system range) between one-transponder and one-RWD antenna centre is considered in common design processes in practice. Whereas the RFID system range is only the basic parameter describing the interrogation zone. Nevertheless, the interrogation zone should be estimated in any direction of space Ω_{ID} for a group of electronic transponders. The greatest flexibility in developing RFID applications and shaping the interrogation zone space can be achieved using a RFID system which includes a phased array antenna (Fig. 1). Because of this, the authors paid particular attention to the problem of energy transfer in the RFID systems with phased array antennas that is more sophisticated than typical applications (with one RWD antenna). Such a solution is used in order to maximize the interrogation zone, especially in automated systems operating in dynamic conditions.

2. Model

The problem to solve is the arrangement of a phased array antenna connected to a single RWD. The antennas have to be switched while marked objects are being identified inside a cube of side b (Fig. 2). The process of energy transfer from RWD to RFID transponders is subjected to the analysis in the study to be carried out.

Defining, characterizing and determining parameters which essentially influence the synthesis process of an interrogation zone in a UHF band was presented based on the example of the proposed model of a radio communication system (Fig. 3). The model represents electrical circuits and an antenna of the read/write device as well as a single transponder (passive or semi-passive). For simplicity, only a single identification process is considered. But, the same algorithm can be multiplied for all arrangements (RWD and additional transponders in an interrogation zone) when the anti-collision system is synthesised.

The internal structure of the electronic chip in the transponder is designed to be supplied by the minimal voltage U_T that is induced at terminals of the transponder antenna. As a consequence, the complex impedance (Z_{TC}) of the chip's front-end is continuously changed. The part (Z_{TCR}) of the impedance that represents a rectifier and voltage regulator is strongly influenced by the electromagnetic field. On the other hand, the electromagnetic field parameters are dependent on the orientation of the marked object and its localization in the operating

space where both energy and communication conditions have to be established in order to ensure that the system can work properly. The conditions are described by the interrogation zone that constitutes the basic parameter of RFID systems. Since the amount of conveyed energy is very small, the backscatter communication is used for transmitting data in the direction from the transponder to the RWD. In this process, a battery-less device communicates by modulating the reflections of an incident RF signal. The modulation is realized by step changes of the chip impedance (Z_{TCM} switching).

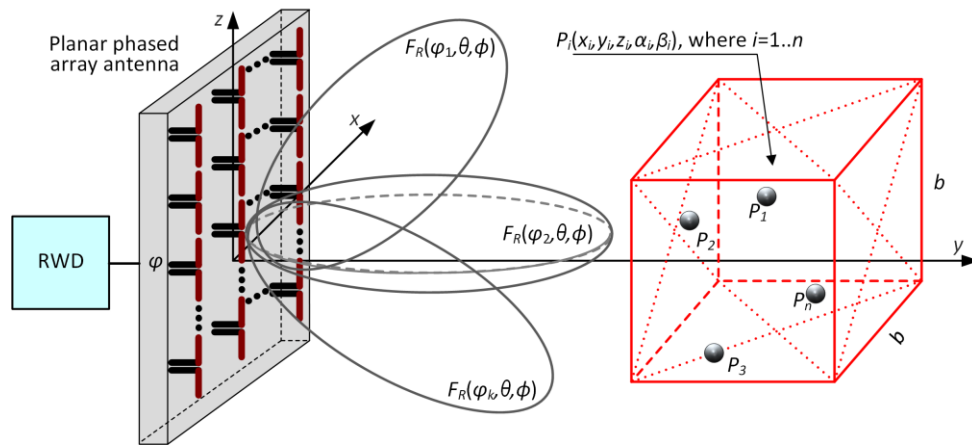

Fig. 2. Problem of objects identification in the UHF RFID systems with RWD planar phased array antenna

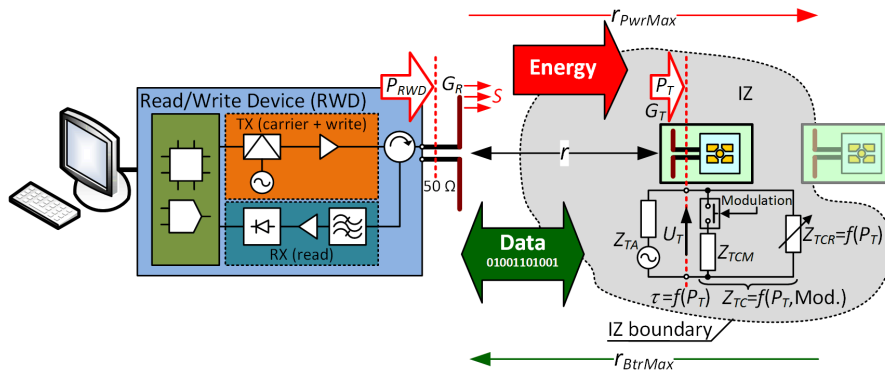

Fig. 3. Generalized Block diagram of an UHF RFID system

The Friis transmission equation can be utilized for determining the interrogation zone of a common radio channel [18]:

$$P_T = P_{RWD} \frac{G_R G_T \lambda^2 \tau \chi}{(4\pi r)^2}, \tag{1}$$

where: P_{RWD} means the power supplied to terminals of the impedance-matched RWD antenna, G_R is the gain of the impedance-matched RWD antenna, P_T is the power received in a transponder antenna, G_T is the gain of a transponder antenna (the chip and antenna impedance matching is assumed), χ is the polarization matching factor for a given arrangement of radio communication antennas, τ is the coefficient of power transfer from the antenna to the chip, λ is the wavelength, r is the distance between antennas.

In the UHF band, the process of communication is possible only if the transponders are located inside the interrogation zone (Fig. 1). This space is primarily shaped by a 50 Ω RWD array antenna, whose EM field is a source of energy for transponders and medium for bi-directional data transmission for the RFID system. However, it is not possible to identify all tagged objects placed in a certain space Ω_{ID} , during the implementation of the automated process. Most of these problems stem from the fact that the EM field energy can be transmitted only on a maximal distance (r_{Pwrmax}), whose dependence arises from the Friis equation (Fig. 3):

$$r_{Pwrmax} = \frac{\lambda}{4\pi} \sqrt{\frac{P_{RWD} G_R G_T \tau \chi}{P_{Tmin}}} . \quad (2)$$

The conditions for supplying enough energy to a passive transponder are established in such a defined space. The conditions are characterized by the minimal power P_{Tmin} (chip sensitivity) which is enough for activating the internal circuits of the transponder. The transponder sensitivity is dependent on its type (passive or semi-passive) as well as on parameters of radio-communication protocol. There is a relation between the sensitivity of a passive transponder chip P_{TminP} and a semi-passive P_{TminSP} one:

$$P_{TminP} > P_{TminSP} . \quad (3)$$

It yields a larger interrogation zone of semi-passive systems. This is due to an extra battery source connected to the chip. But it should be emphasized that relation (3) is valid when the voltage of an internal source is in the range of minimal U_{Batmin} and maximal U_{Batmax} values (Fig. 4). Therefore, the sensitivity of a semi-passive chip should be specified for the given voltage value of an internal supply module U_{Bat} .

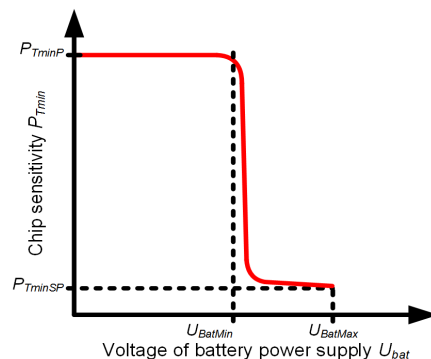

Fig. 4. Generalized curve of sensitivity for passive and semi-passive chip

The maximal distance r_{Pwrmax} has to be compared with the r_{Btrmax} value in the process of interrogation zone synthesis. r_{Btrmax} means the maximal distance between centres of radio communication system antennas where the proper detection of the transmission signal is possible [1, 19]:

$$r_{Btrmax} = 4 \sqrt{\frac{\lambda^2 P_{RWD} G_R^2 \chi \sigma_T}{(4\pi)^3 P_{Rmin}}}, \quad (4)$$

where: σ_T means the effective reflecting area of a transponder antenna (Radar Cross Section – RCS), P_{Rmin} – is the minimal power at the RWD input for a signal wave reflected off the transponder.

The signal is transmitted by backscatter communication in the direction from the transponder to the read/write device. The process of data exchange can be carried out successfully provided only that the power in antenna circuits of both the RWD and transponder reaches the necessary level. The energy gathered by the transponder in a point (x, y, z) has to be enough to supply the chip with a power P_T greater than the minimal value P_{Tmin} . Also, the energy of a signal wave reflected back to the RWD antenna has to be sufficient to give a power P_R greater than the P_{Rmin} value.

$$\frac{P_T(x, y, z)}{P_{Tmin}} \geq 1, \quad \frac{P_R(x, y, z)}{P_{Rmin}} \geq 1. \quad (5)$$

Equations (1)-(5) can be used to determine the interrogation zone in passive or semi-passive RFID systems of the UHF band. It should be borne in mind, however, that many of the listed parameters depend on electrical and geometrical arrangements of RWD and transponder antennas. This is particularly important in dynamic and anti-collision RFID systems which are dedicated to automated processes of object identification. For example, despite the antenna polar diagrams of $G(\theta)$ and $G(\phi)$, the three-dimensional antenna radiation pattern $G(\theta, \phi)$ has to be taken into consideration when the orientation of a labelled object is changed in all directions. Moreover, the chip sensitivity (i.e. minimal power P_{Tmin}) is most important in the interrogation zone synthesis process. On the basis of this parameter, the chip impedance placed at the interrogation zone boundary, the construction of the transponder antenna and the shape of the interrogation zone for a given implementation of an RFID system are worked out.

The impedance of transmitters or receivers in conventional radio systems is fixed (e.g. 50, 75 Ω) and matched to the antenna at a given frequency. Another situation is in passive and semi-passive RFID systems. The chip impedance Z_{TC} varies while the transponder is working. The impedance matching of the chip and antenna Z_{TA} is characterized by the power transfer coefficient τ (Fig. 3).

The gain G_T in Equations (1) and (2) has to be determined at full impedance matching of the antenna and chip ($Z_{TA} = Z_{TC}^*$, $\tau = 1$) in order to carry out the interrogation zone synthesis. The power transfer coefficient is described by the formula:

$$\tau = \frac{4 \operatorname{Re}(Z_{TA}) \operatorname{Re}(Z_{TC})}{\operatorname{Re}(Z_{TA} + Z_{TC})^2 + \operatorname{Im}(Z_{TA} + Z_{TC})^2}. \quad (6)$$

In practice, the antenna impedance Z_{TA} is constant at a given frequency but the chip impedance Z_{TC} varies while the transponder is working (Fig. 3). This characteristic is crucial in the interrogation zone synthesis, but producers of RFID components do not specify it.

The proposed concept of an increase geometric size interrogation zone in the UHF RFID system by using the phased array antenna so it can be described using the features, which include the location of the k -th position of the main beam in relation to the n -th transponders space Ω_{ID} is:

$$IZ(\Omega_{ID}) = f(F_R(\varphi_k, \theta, \phi), F_{Tn}(\theta, \phi), \tau_n, \chi_n, P_{RWD}, P_{Tmin}), \quad (7)$$

where: $F_R(\varphi_k, \theta, \phi)$ means the radiation pattern of the RWD phased array antenna, $F_{Tn}(\theta, \phi)$ is the transponder radiation pattern, whereas φ is the angle of phase shift in the course of feeding the individual array antennas.

Equations (1)-(7) are implemented in the simulator software in the form of short numerical programs.

The exemplary location and orientation of n -transponders is analyzed in Fig. 2. It is difficult to accurately predict the coordinates of the points P_i in a chaotic state. In fact, it isn't possible to analyse all potential locations and orientations of a group of n -transponders in the inside of a cube of side b . The described problem has a probabilistic nature, and the proposed solution is obtained by simulating the group of given objects by using the Monte Carlo method [9].

3. Results

A key aim of the study has been to elaborate the numerical model. The utility program called RFIDphaseUHF has been developed on the basis of this model (Fig. 5).

The program can be used for calculating the identification efficiency for the given input data. Input data are determined on the basis of primary parameters of the UHF RFID system with phased array antenna.

The results of the identification process are presented graphically along with efficiency effects. A user may select any format of output data for further analysis during preparation of graph visualization e.g. in the OriginPro software. An example of the output result is presented in Fig. 8.

The example calculations are performed for 100-transponders and a set of tests of a UHF band phased array antenna [20], which include: two antennas (spaced apart by half a wavelength related to the frequency $f = 866$ MHz) supplied by the RWD. Transponders and a phased array antenna have an axisymmetric, directional radiation pattern. Spatial orientation of the transponders are not changed ($\alpha = 0, \beta = 0$).

The essence of the model is represented by the algorithm which defines the geometric size of the interrogation zone in a UHF RFID system with the use of the Monte Carlo method. It is partially shown in Fig. 6. In this case, it is assumed that the search will be conducted inside a cube with an initial size b_{init} and center coordinates $(X_{cube}, Y_{cube}, Z_{cube})$. Numerical calcula-

tions are carried out by steps (repeated k -times). If one of the energetic conditions were not met for any of the n -transponders, the calculation is interrupted, the size of the study area is reduced by distance b_{step} and the search for the correct interrogation zone starts from the beginning. Numerical calculations are carried out as often as the energetic conditions are not met by all n -transponders invested in the study of the cubic space of size b , for each of the k -steps calculations. To increase the accuracy of calculations, the number of sample transponders is increased m -times.

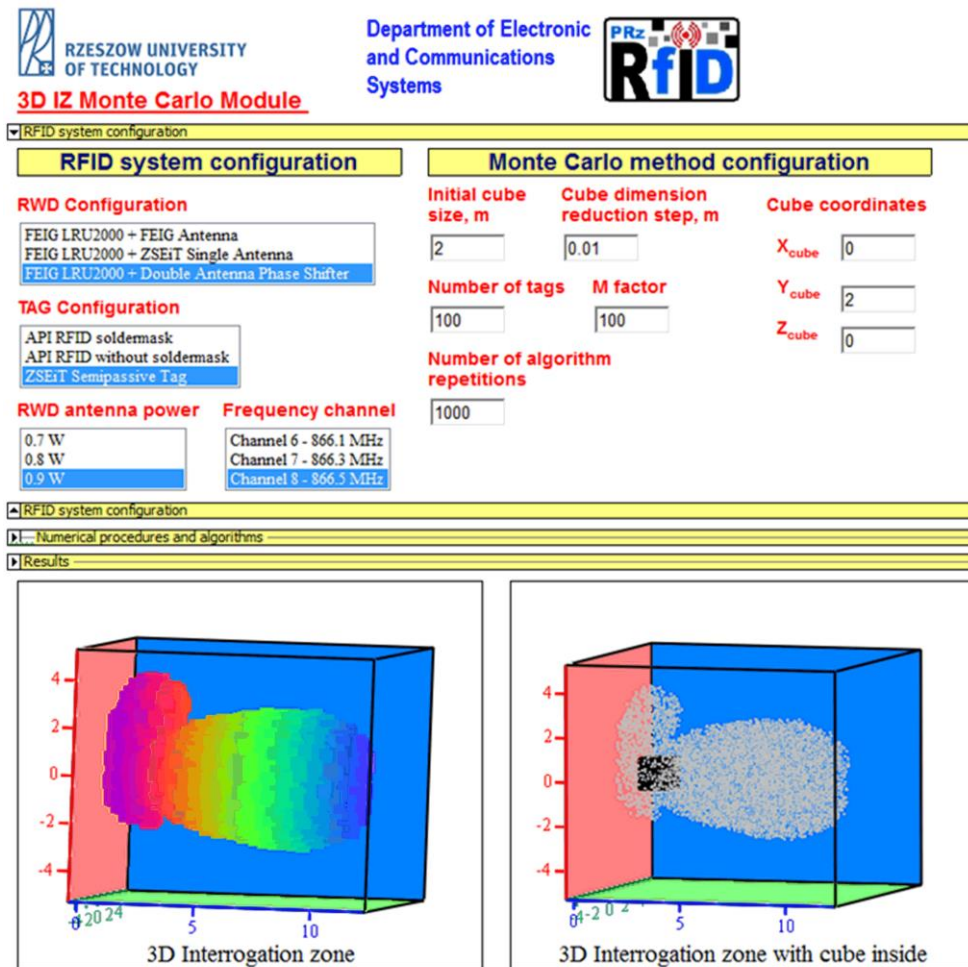

Fig. 5. *RFIDphaseUHF* program

Experimental verification of the case were cophasal supplied (Fig. 7 – black line) and phased at angle $\varphi = 30^\circ$ (Fig. 7 – red line). The first case ($\varphi = 0^\circ$) the maximal distance in which the energy can be transmitted $r_{Pwrmax} = 2.5$ m. In turn, in the case specified above, a phase angle in signals supplying the individual antenna system ($\varphi = 30^\circ$) $r_{Pwrmax} = 3$ m.

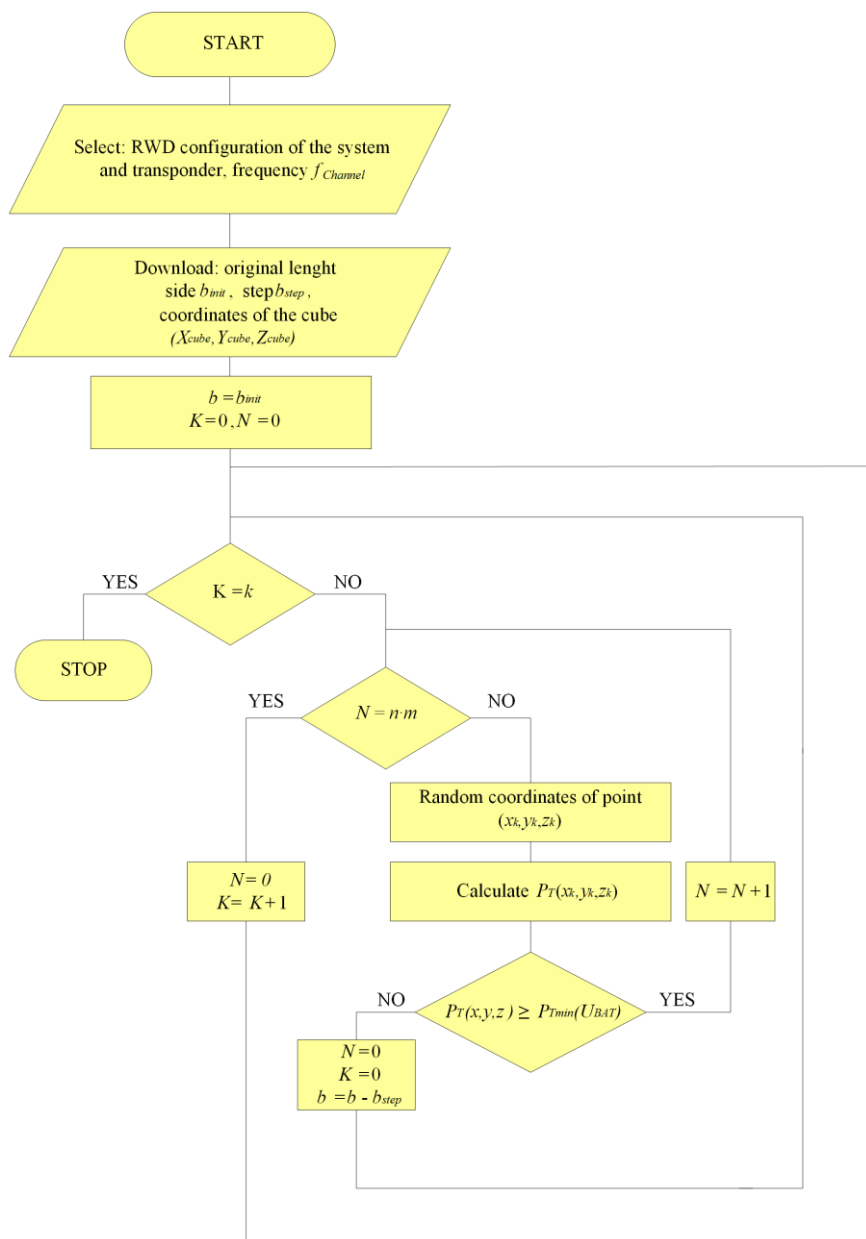

Fig. 6. The block diagram algorithm of the interrogation zone of a UHF RFID system with the use of the Monte Carlo method

In Fig. 8, there are examples of a cross section of an interrogation zone, successively set in XY, YZ and XZ coordinate planes. The cross sections are based on the full radiation pattern measurements of the phased array antenna and transponder. The colours of the drawings indicate the number of times the received power at that point is greater than the minimal (P_{Tmin}).

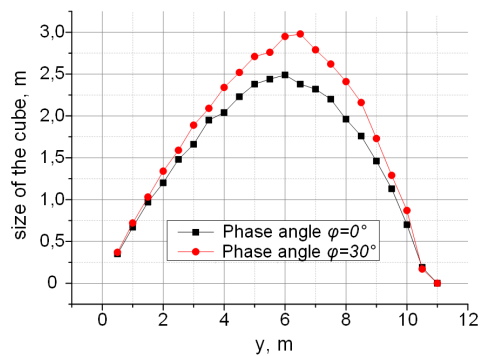

Fig. 7. The sample results of the size of the interrogation zone determined in calculation process for: $\varphi = 0^\circ$ and $\varphi = 30^\circ$

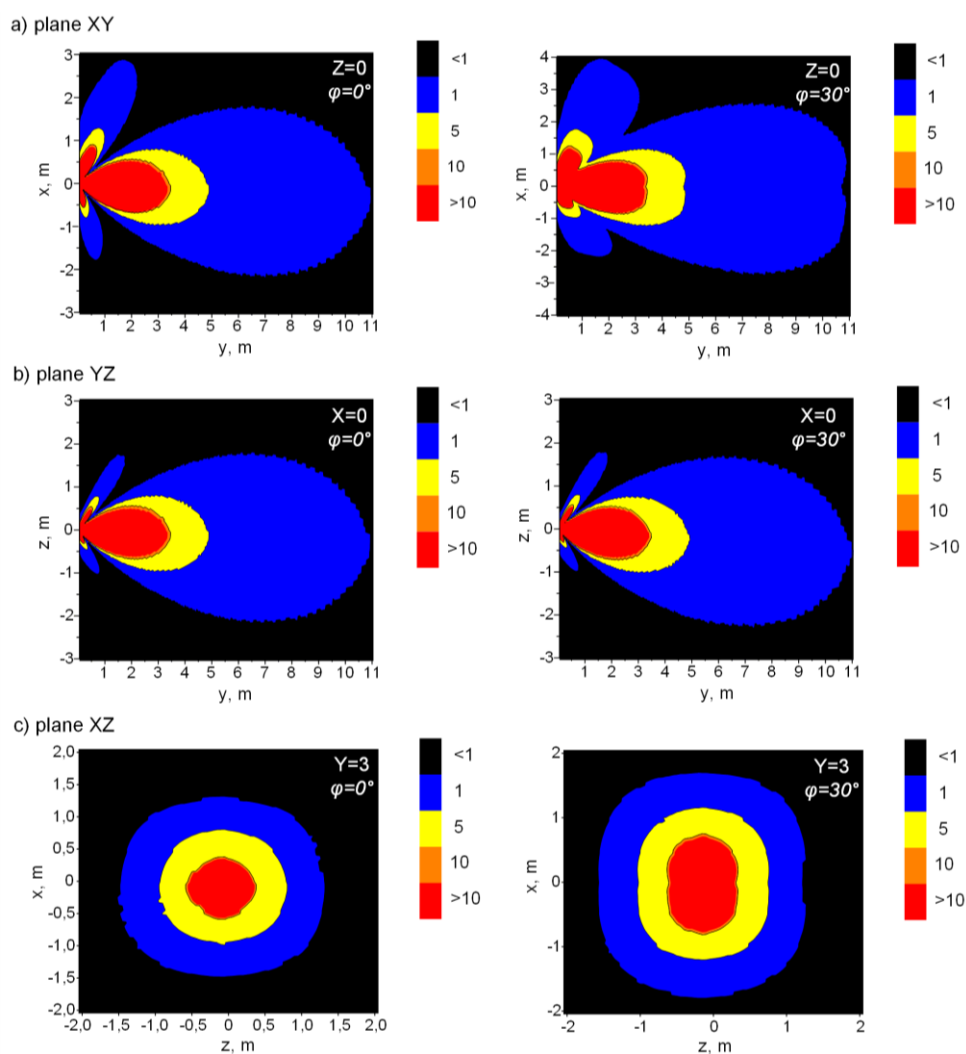

Fig. 8. Cross section of the interrogation zone done in coordinate plane: a) XY; b) YZ; c) XZ

The black colour indicates that the power emitted at the load transponder is not sufficient for its operation. By analyzing the summarized data, it can be noted that the shape of the cross-section is similar to the directional radiation pattern diagrams.

4. Conclusions

Anti-collision RFID systems are primarily required to recognize all marked objects in a specified working space. This is of key importance in many areas of life and economy, because the speed and quality of the implementation of automated processes largely depend on the cost of material flows. However, the observed progress in this area indicates the need to overcome some technical barriers that stand in the way of dissemination of already developed standards (as is the case of the EPC (for example)). Therefore it can be concluded that increasing the geometric size of the interrogation zone of a RFID system (and thus maximizing the reach of read/write data with transponders memory) is one of the factors that leads to predictable recognition of objects in non-stationary state (e.g. electronically marked fast-moving consumer goods (FMCG)).

An effective implementation of an RFID system can be ensured only on the basis of accurate study of operation conditions that can be established in the automatic identification process. In the case of an RFID system, it is crucial to determine the *IZ* parameter that should be estimated in any direction of space. This is difficult in anti-collision applications, especially when marked objects dynamically change their location and orientation in the space.

The phased array antenna is the most flexible method that can be used in order to enlarge the interrogation zone of an RFID system. It is also suitable for shaping boundaries of this space. For this reason, the problem of the interrogation zone determination in UHF RFID systems with a phased array antenna is presented in the paper. The perceived issues have been effectively dealt with and the solution has been proposed on the basis of the elaborated model. It should be emphasized that the elaborated model can be easily supplemented by additional RWD antennas, and their localization in the space can be changed.

Acknowledgements

Results of Grant No. PBS1/A3/3/2012 from Polish National Centre for Research and Development as well as Statutory Activity of Rzeszow University of Technology were applied in this work. The work was developed by using equipment purchased in Operational Program Development of Eastern Poland 2007-2013, Priority Axis I Modern Economics, Activity I.3 Supporting Innovation under Grant No. POPW.01.03.00-18-012/09-00 as well as Program of Development of Podkarpace Province of European Regional Development Fund under Grant No. UDA-RPPK.01.03.00-18-003/10-00.

References

- [1] Finkenzeller K., *RFID Handbook*, 3-rd ed., Wiley (2010).
- [2] Ustundag A., *The Value of RFID, Benefits vs. costs*, Springer-Verlag (2013).
- [3] Costa C., Antonucci F., Pallottino F. et al., *A Review on agri-food supply chain traceability by means of RFID technology*, Food Bioprocess Technol., vol. 6, no. 2, pp. 353-366 (2013).

- [4] Wheeler M., *Automating processes with RFID*, Global Identification, vol. Feb., pp. 10-13 (2013).
- [5] GS1 EPCglobal: EPC Radio-Frequency Identity Protocols Generation-2 UHF RFID, *Specification for RFID Air Interface Protocol for Communications at 860 MHz – 960 MHz*, ver. 2.0.0 (2013).
- [6] Longfei L., Qishan Z., *Design and implementation of a long-range RFID reader*, in proc. of the 10th International Conference on Electronic Measurement & Instruments (ICEMI), © ICEMI (2011), DOI: 10.1109/ICEMI.2011.6037735
- [7] Sabesan S., Crisp M.J., Penty R.V., White I.H., *Wide Area Passive UHF RFID System Using Antenna Diversity Combined With Phase and Frequency Hopping*, in IEEE Transactions on Antennas and Propagation (TAP), © TAP (2014), DOI: 10.1109/TAP.2013.2290114
- [8] Azzouzi S., Cremer M., Dettmar U., Kronberger R., Knie T., *New Measurement Results for the Localization of UHF RFID Transponders Using an Angle of Arrival (AoA) Approach*, in proc. of the IEEE International Conference on RFID, © RFID (2011), DOI: 10.1109/RFID.2011.5764607
- [9] Jankowski-Mihulowicz P., Węglarski M., *Determination of 3-dimensional interrogation zone in anticollision RFID systems with inductive coupling by using monte carlo method*, Acta Physica Polonica A, vol. 121, no. 4, pp. 936-940 (2012).
- [10] Shi J., Qing X., Chen Z. N., *Electrically Large Zero-Phase-Shift Line Grid-Array UHF Near-Field RFID Reader Antenna*, IEEE Transactions on Antennas and Propagation (TAP), © TAP (2014), DOI: 10.1109/TAP.2014.2299824
- [11] Wang-Sang L., Seung-Tae K., Won-Seok L., Jong-Won Y., *Hemispheric coverage multi-beam switched antenna array using a 4-port feeding network for UHF RFID dead zone avoidance*, in proc. of the Asia-Pacific Microwave Conference Proceedings (APMC), © APMC (2013), DOI: 10.1109/APMC.2013.6695111
- [12] Wang-Sang L., Hyun-Sung T., Jong-Won Y., *Quadruple-feed beam-controlled antenna array for the localisations of ultra-high-frequency radio-frequency identification tags*, IET Microwaves, Antennas & Propagation (IET-MAP), © IET-MAP (2015), DOI: 10.1049/iet-map.2014.0158
- [13] Zieniutycz W., Ed., *The antenna of the radar technique beam steering*, Warsaw: WKŁ (2012).
- [14] Li X., Liao J., Yuan Y., Yu D., *Eye-shaped segmented reader antenna for near-field UHF RFID applications*, Progress In Electromagnetics Research, vol. 114, pp. 481-493 (2011).
- [15] Dhaouadi M., Mabrouk M., Vuong T.P., de Souza A.C., Ghazel A., *A capacitively-loaded loop antenna for UHF near-field RFID reader applications*, IEEE Radio and Wireless Symposium (RWS), © RWS (2015), DOI: 10.1109/RWS.2015.7129755.
- [16] Caso R., Michel A., Rodriguez-Pino M., Nepa P., *Dual-Band UHF-RFID/WLAN Circularly Polarized Antenna for Portable RFID Readers*, IEEE Transactions on Antennas and Propagation (TAP), © TAP (2014), DOI: 10.1109/TAP.2014.2303971.
- [17] De Vita G., Iannaccone G., *Design criteria for the RF section of UHF and microwave passive RFID transponders*, IEEE Trans. Microw. Theory Tech., vol. 53, no. 9, pp. 2978-2990 (2005).
- [18] Balanis C., *Antenna Theory*, 3-rd ed., Wiley (2005).
- [19] Dobkin, D., *The RF in RFID*, UHF RFID in Practice, Newnes (2012).
- [20] Jankowski-Mihulowicz P., Kawalec D., Węglarski M., *The Idea of Enhancing Directional Energy Radiation by a Phased Antenna Array in UHF RFID System*, International Journal of Electronics and Telecommunications (2016), DOI: 10.1515/eletel-2016-0015.
- [21] His-Tseng C., Ming-Yu L., Chien-Te Y., *Implementation scenario of phase array antennas with beam-scan functionality for RFID applications*, 10th European Conference on Antennas and Propagation (EuCAP), IEEE Conference Publications, © EuCAP 2016, DOI: 10.1109/EuCAP.2016.7481528.
- [22] Jankowski-Mihulowicz P., Węglarski M., Pitera G., Kawalec D., Lichoń W., *Development board of the autonomus semi-passive RFID transponder*, Bulletin of The Polish Academy of Sciences Technical Sciences (BPASTS), © BPASTS (2016), DOI: 10.1515/bpasts-2016-0073.