

INFLUENCE OF GEOMETRIC CHARACTERISTICS OF THE BOMB-FLUGER SYSTEM ON ITS DYNAMICS

Grzegorz Kowaleczko, Mariusz Pietraszek, Tomasz Klemba

Polish Air Force Academy
Dywizjonu 303 Street 35, 08-521 Deblin, Poland
tel.: +48 261 865 330
e-mail: grzegorz.kowaleczko@itwl.pl
mariusz.pietraszek@itwl.pl, tomasz.klemba@itwl.pl

Andrzej Żyluk

Polish Air Force Academy
Dywizjonu 303 Street 35, 08-521 Deblin, Poland
tel.: +48 261 865 330, +48 261 865 302, +48 261 865 445
e-mail: andrzej.zyluk@itwl.pl

Abstract

The article presents the results of numerical simulations of the bomb-fluger system drop. This system consists of two rigid bodies – a bomb and a fluger, which are connected by a biaxial joint. For the analysis, an author's program was used to simulate the bomb-fluger system drop. Influence of the characteristic points of the system on its stability and dynamics was investigated. Particularly, locations of a bomb mass centre, a fluger mounting point, a fluger aerodynamic focus were tested. The article presents a model of the examined bomb in the wind tunnel, characteristic points of a bomb-fluger system, waveforms of values rate of change angles and the values of angles for different distances, waveforms of values of the angle of nutation and the pitch angle of the fluger relative to the bomb, diagrams of examined points of the location of the centre of the mass and pressure of the fluger, waveforms of values rate of change angles and the values of these angles for different locations of the centre of the mass of the fluger, waveforms of values of the angle of nutation and the pitch angle of the fluger relative to the bomb for different locations.

Keywords: *guided bombs, bomb-fluger system, aerodynamics simulations*

1. Introduction

One of the applied construction solutions of guided bombs is a bomb-fluger system. Such solution is applied for corrective bombs equipped with half-active systems detecting laser radiation reflected from the highlighted target. The optoelectronic detection system of laser radiation is mounted inside the fluger, which is an aerodynamical device rigidly connected with a bomb. The fluger is installed with the use of immovable extension arm and cardan joint at the front part of the bomb. Such fixing gives the possibility of the free movement of the fluger (in a limited scope) relative to the bomb in the inclination and deviation surfaces. Thanks to its aerodynamic stability, the fluger being flowed by the air is set parallel to the velocity vector of the whole system. If the detecting system is installed inside the fluger then it is more resistant to changes of bomb flight parameters – detected signal disturbances caused by this changes are smaller, or do not occur, and a guidance system works stable.

Armaments Division of the Air Force Institute of Technology (ITWL) carries out research works focused on designing, manufacturing and testing of the bomb based on the described construction solution [6-8]. In the described system, the fluger is a very important element and its work depends on the properly designed system structure.

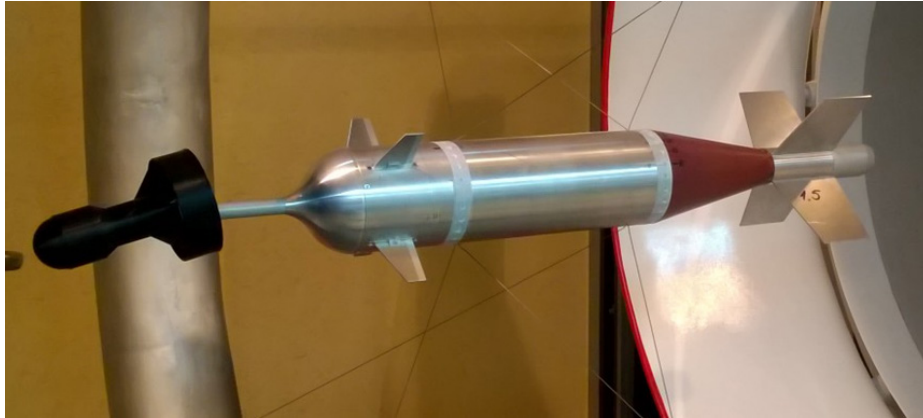

Fig. 1. Model of the examined bomb in the wind tunnel

In this work, the attempt was made to examine the influence of geometric characteristics of bomb-fluger system on its dynamics. In particular, the attention was paid to the mutual location of points characterizing the whole dynamic system such as:

- M – mounting points of the fluger on the bomb,
- F – mass centre of the fluger,
- A – fluger aerodynamic focus,
- B – mass centre of the bomb.

Theoretic analysis of the influence of the characteristic point's location on the dynamics of the system was performed on the basis of computer simulation results. The evaluation of these results was made by comparing the following values:

- Q – pitching angular velocity of the bomb,
- q_f – pitching angular velocity of the fluger (relative to the bomb),
- Θ – pitch angle of the bomb,
- $\Theta_{b/f}$ – pitch angle of the fluger (relative to the bomb),
- α_t nutation angle of the bomb.

2. Theoretical analysis

All calculations were performed using author's programme, which is based on the mathematical model described in details in [3]. The main assumptions of this model are as follows:

- the bomb-fluger system is the system of two rigid bodies with eight degrees of freedom, on which act the gravitational and aerodynamic forces [1-5],
- the fluger is installed in the front of the bomb on the immovable extension arm and it is possible to deflect the angles $\Theta_{b/f}$ and $\Psi_{b/f}$,
- the bomb and the fluger have two surfaces of the mass and aerodynamic symmetry ($B_{x_b y_b}$ and $B_{x_{b/f} y_{b/f}}$) overlapping with the control surfaces.

This model gives the set of 16 differential equations describing both bomb and fluger spatial motions.

The applied programme allows calculating the drop of the bomb-fluger system for different initial conditions and various geometric parameters of the system. The following variables [9] can be changed:

- initial conditions:
 - height of the drop,
 - initial velocity vector,
 - initial angular velocity,
 - initial bomb pitch angle,
 - initial bomb roll angle;

- geometric parameters:
 - location of the mounting point of the fluger (point M) relative to the bomb mass centre (point B),
 - location of the of the fluger mass centre (point F) relative to the mounting point (point M),
 - location of the fluger centre of pressure (point A) relative to the mounting point (point M).

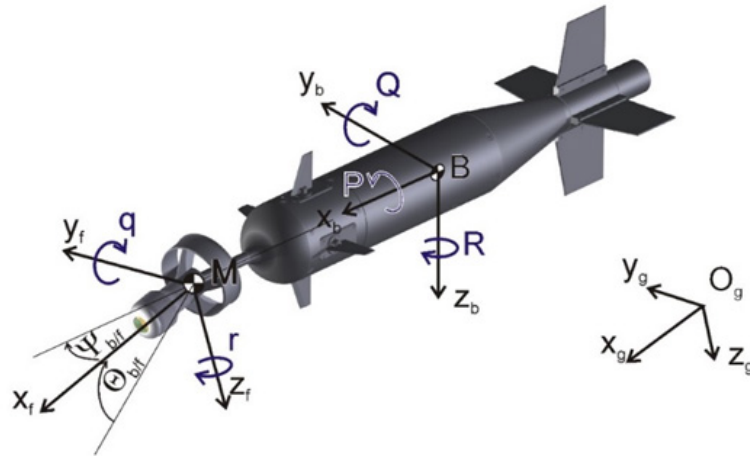

Fig. 2. Coordinate systems

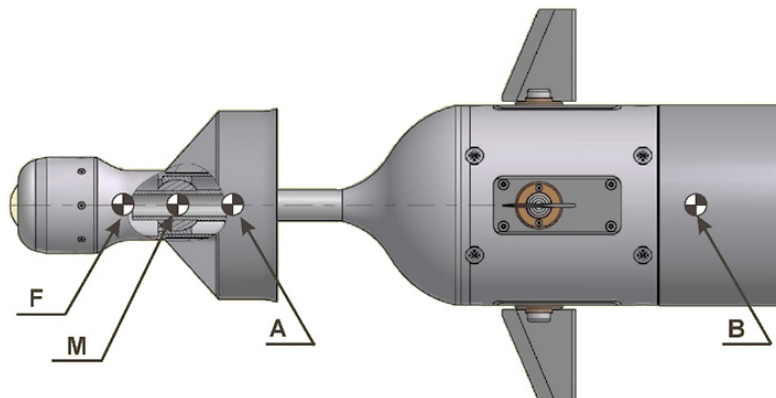

Fig. 3. Characteristic points of a bomb-fluger system

3. Simulation results

Due to design reasons, taking into account the actual dimensions of bomb, for research were earmarked the bomb with a frame diameter 110 mm, mass 15 kg. The fluger mounting enables its pitching and yawing motion by $\pm 15^\circ$. The drop of bomb from the height of 3000 m, with the speed of 55 m/s, and pitch angle 20° was simulated. Influence of a few geometric parameters on the system dynamics was tested. This is discussed below.

3.1. Influence of the extension arm length

At the beginning, taking into account the structural limits, the influence of the length of extension arm on the dynamics of the system was investigated. Following values of the distance between bomb mass centre and the fluger mounting point were tested: $L_{m1}=300$ mm, $L_{m2}=400$ mm, $L_{m3}=500$ mm. This distance is marked in Fig. 4 as L_m .

Figure 5 presents time courses of two angular velocities and two angles. We have: Q – the bomb pitching angular velocity, q_f – the fluger pitching angular velocity, Θ – the bomb pitch

angle, $\Theta_{b/f}$ – the fluger pitch angle (relative to the bomb). The waveforms denoted with a blue colour corresponded to values of the distances L_{m1} , with a red colour – L_{m2} and with a green colour – L_{m3} . Fig. 6 presents the nutation angle of the bomb α_t versus the absolute value of $\Theta_{b/f}$. If these courses are consistent, the bomb velocity vector coincides with the fluger's axis. This is the principal condition for the correct operation of the system. One can see that only at the moment of maximum of fluger oscillations there are slight discrepancies.

All results presented in Fig. 5 and 6 show that the tested configurations are stable – all oscillations are damped. Courses of $\Theta_{b/f}$ proof that the fluger oscillates in the operating limit $\pm 15^\circ$. The influence of the tested distances between the bomb mass centre and the fluger mounting point on fluger and bomb motions is small and can be neglected. Therefore for further simulations the value $L_m=400$ mm would be chosen.

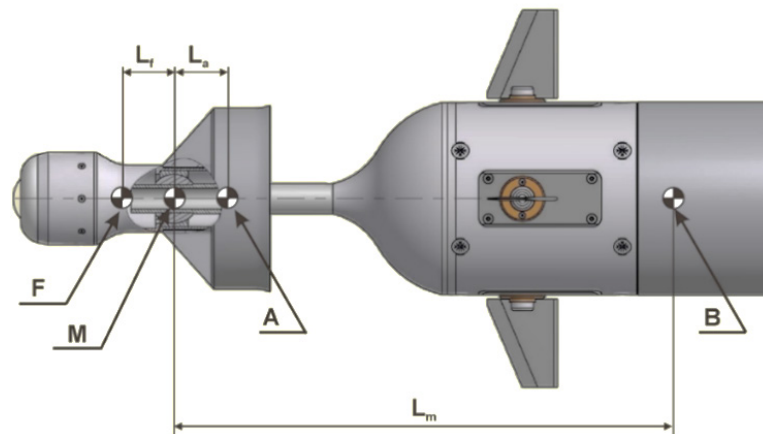

Fig. 4. Tested distances L_m , L_f and L_a

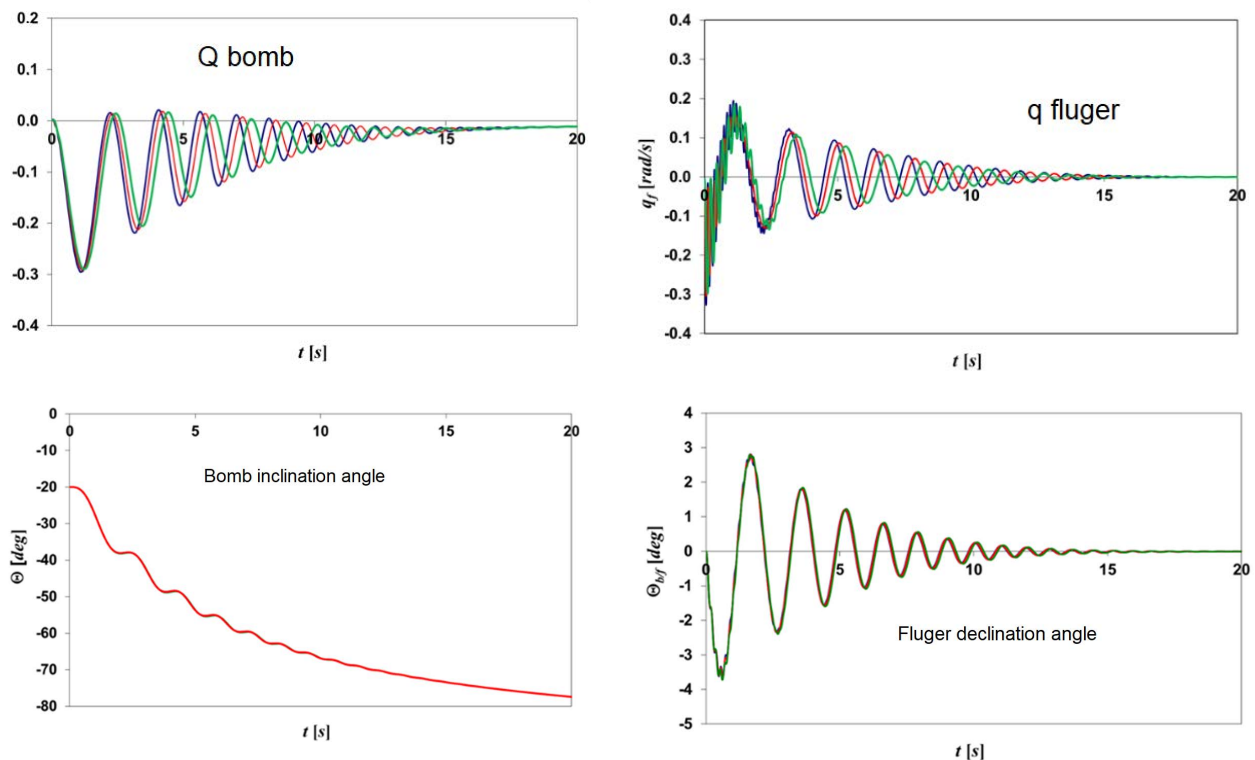

Fig. 5. Waveforms of values rate of change angles Θ and $\Theta_{b/f}$ and the values of these angles for different distances L_m

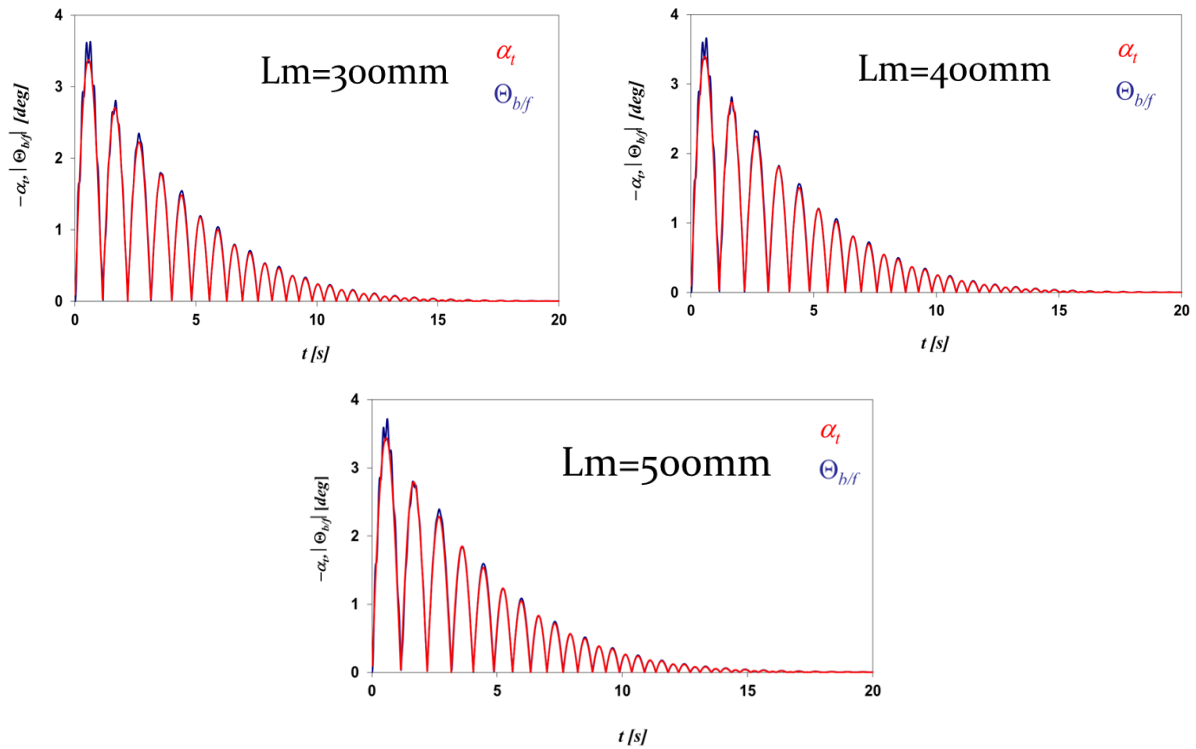

Fig. 6. Waveforms of values of the angle of nutation and the pitch angle of the fluger relative to the bomb for different L_m

3.2. Influence of the fluger mass centre location

Whole electronic detection system of laser radiation is mounted inside the fluger. Additionally diverse materials may be used in the fluger construction. Therefore, location of its mass centre may vary. It can affect the dynamics of the bomb-fluger system and its correct operation. To verify the possibilities three device versions with different distances between the fluger mass centre (point F) and the mounting point were examined (point M). The location of points F under consideration was as shown in Fig. 7:

- point F1 was located 25 mm in front of the point M,
- point F2 coincided with point M,
- point F3 was located 25 mm behind the point M.

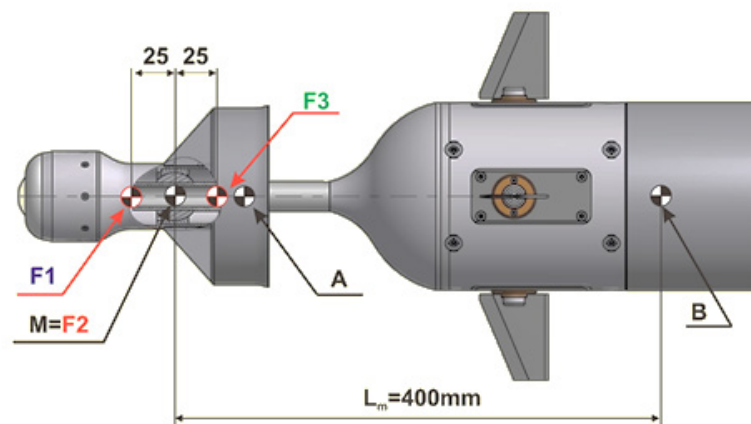

Fig. 7. Diagram of examined points of the location of the centre of the mass of the fluger

Figure 8 present the same parameters that were previously shown in Fig. 6. The blue line is for F1 case, the red for F2 and the green for F3. All courses shown that the system is stable regardless

they position of the fluger mass centre. The only significant changes concern the frequency of oscillations. It is typical reaction of the dynamic system to changes of this parameter. Damping of all waveforms is the same. The crucial parameter – the pitch angle of the fluger $\Theta_{b/f}$ is in the safe range.

Paying attention especially to the initial flight phase (the first 3 seconds) it can be noticed that for coincidence between points F2 and M changes of angular velocities have the smoothest character – a short period oscillations are not observed. If the point F is outside the mounting point this kind, oscillation arises. They characterize rotational motion of the fluger about the mounting point.

By analysing, the courses of the bomb nutation angle α_t and the fluger pitch angle $\Theta_{b/f}$, it is noticeable that in all cases the system works correctly (Fig. 8). The most advantageous character of presented waveforms is observed in the case of overlapping of points F and M.

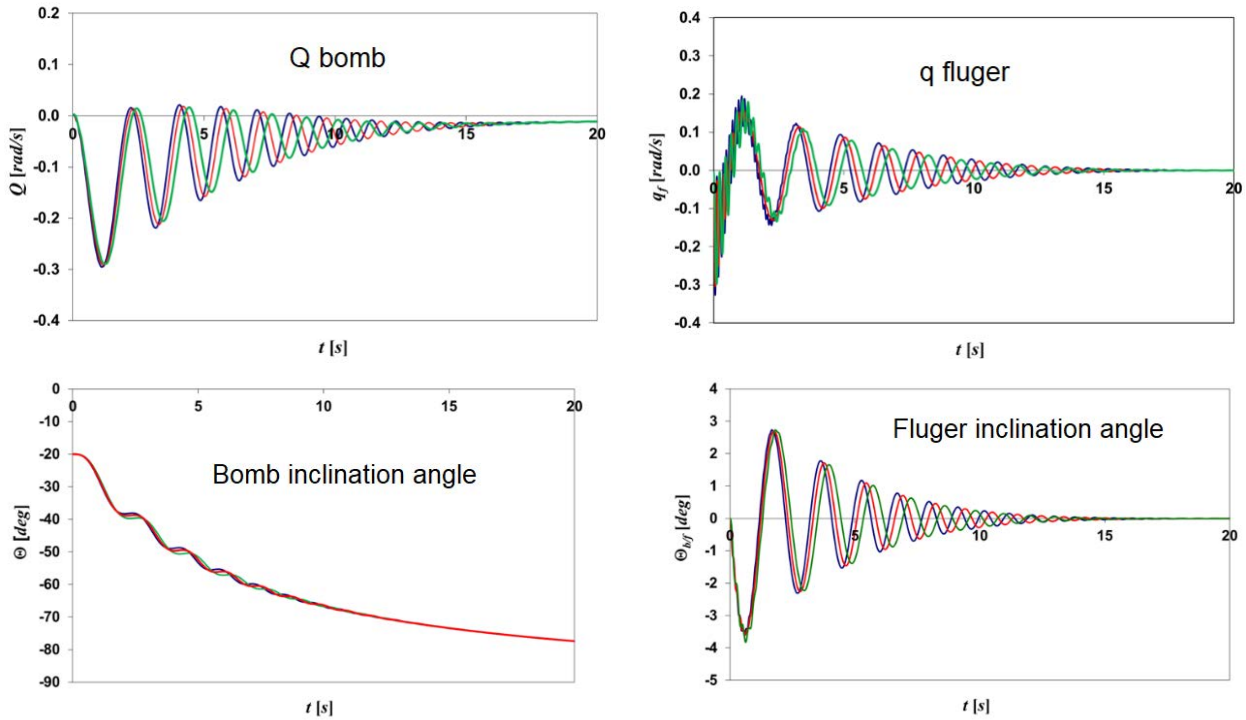

Fig. 8. Waveforms of values rate of change angles Θ and $\Theta_{b/f}$ and the values of these angles for different locations of the centre of the mass of the fluger

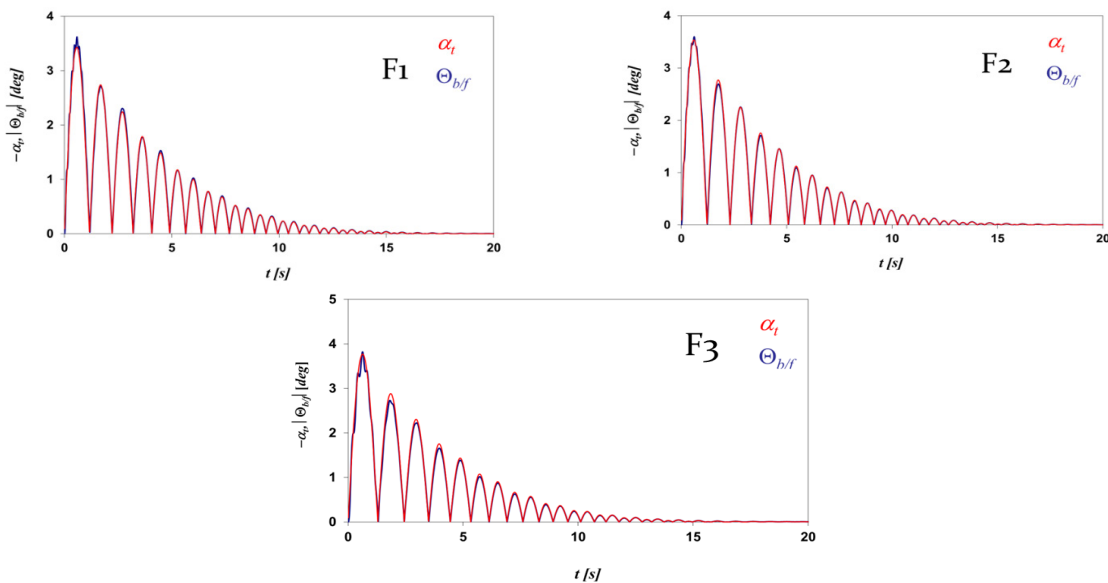

Fig. 9. Waveforms of values of the angle of nutation and pitch angle of the fluger of the bomb relative to the bomb for different locations of point F

3.3. Influence of the fluger aerodynamic focus

To ensure the correct operation of guidance system, the fluger has to be dynamically stable. For aerodynamic objects, the location of the aerodynamic focus (or the centre of pressure) is of key importance. Therefore, the next step of investigations was devoted to analyse an influence of this location on the dynamics of the whole system.

Three possible variants of this location were analysed. They are shown in Fig. 10 and are as follows:

- point A1 was located at the mounting point M,
- point A2 was located 2 mm behind the mounting point M,
- point A3 was located 50 mm behind the mounting point M.

For all these simulations, fluger mass centre was placed at the mounting point M.

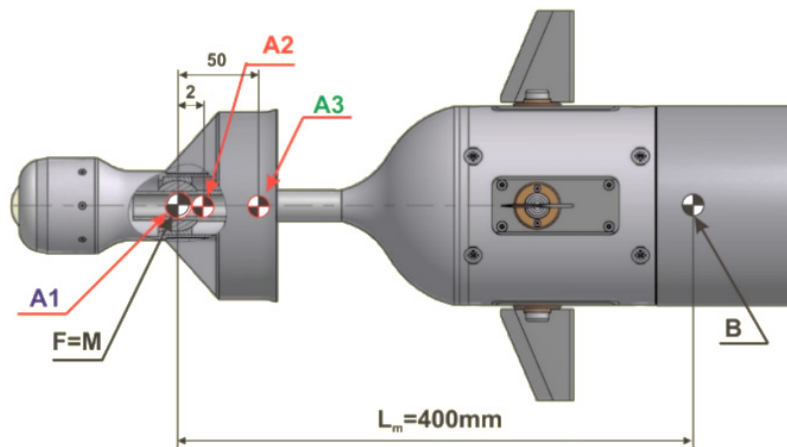

Fig. 10. Diagram of the examined points of the location of the centre of pressure of the fluger

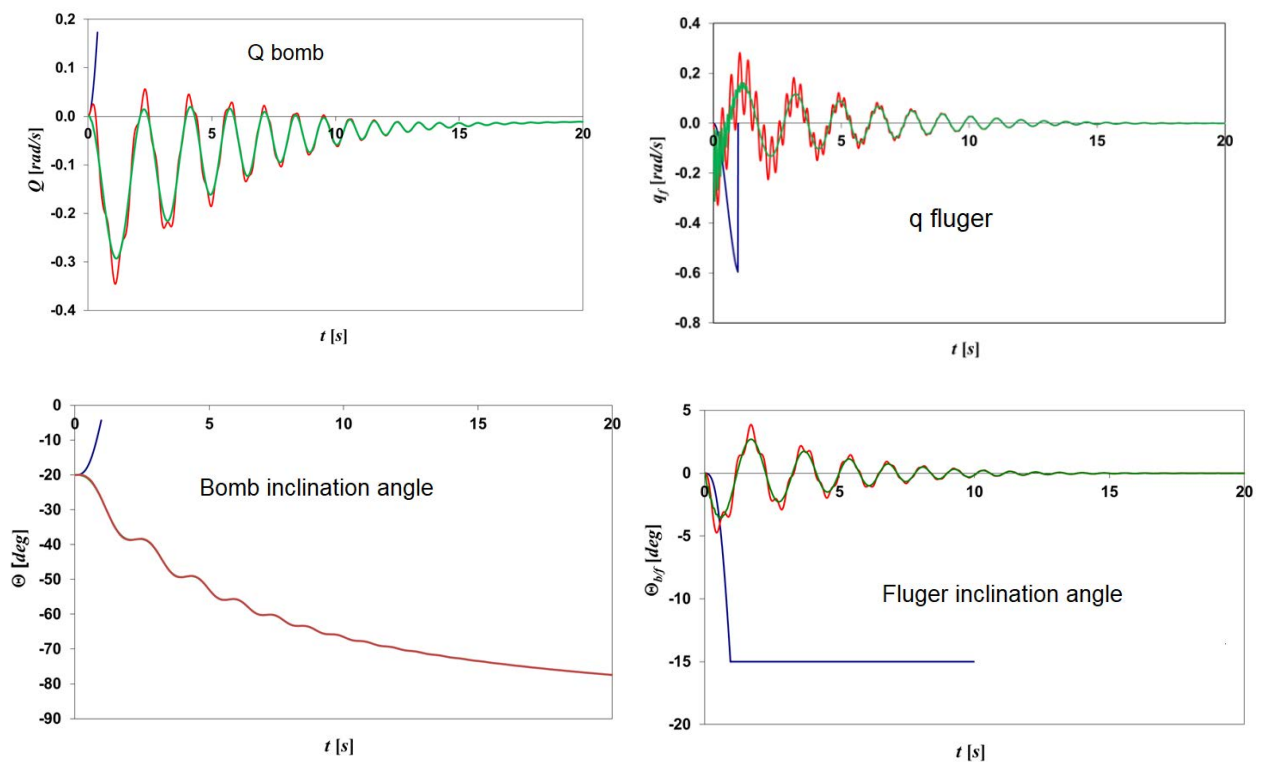

Fig. 11. Waveform of values rate of change angles Θ and Θ_{bf} and values of these angles for different locations of the centre of pressure

As before, Fig. 11 shows angular velocities and pitch angles for the bomb and the fluger. The blue line is for the A1 case, the red for A2 and the green for A3. We can see that if the aerodynamic focus overlaps with the mounting point the system is unstable. Oscillations are not observed – the bomb pitch angle Θ increases in short time and the pitch angle of the fluger $\Theta_{b/f}$ reaches the limit value. The results demonstrate that in this case, the fluger does not work correctly, is not aerodynamically stable, and negatively affects the operation of the whole system. If points A is 2 mm behind the mounting point M, all courses are damped but superposition of long-period and short-period oscillations is visible. If the aerodynamic centre is longer distance behind the point M short-period oscillations are eliminated. This is the optimal configuration of the bomb-fluger system.

The above observations are confirmed by the waveforms shown in Fig. 12. We can see that in the case A1, when the fluger pitch angle $\Theta_{b/f}$ reaches the limit value, its nutation angle α_t is outside the operating range. For the case, A2 both angles coincidence, except the moments of extreme fluger deflections. If the aerodynamic centre is 50 mm, behind the point M both angles overlap all time and their courses are smooth. It confirms the proper operation of the whole system.

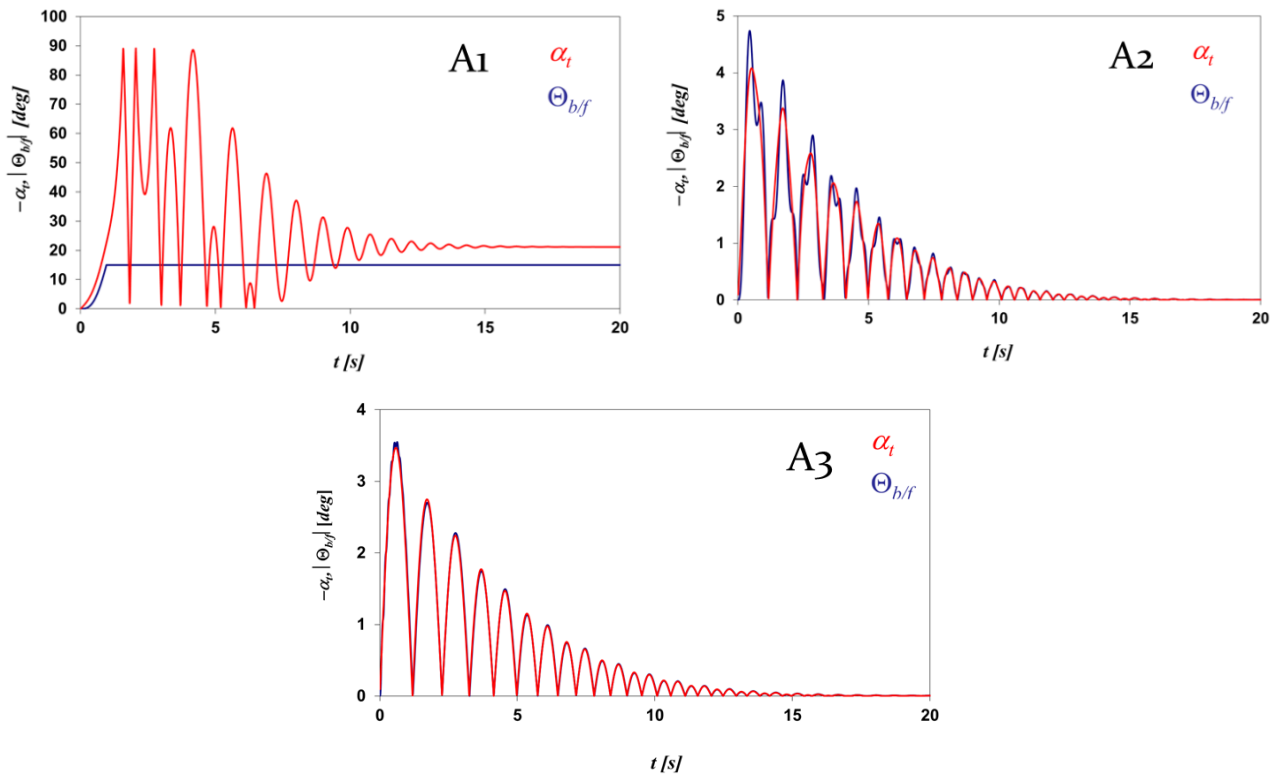

Fig. 12. Waveforms of values of the angle of nutation and the pitch angle of the fluger relative to the bomb for different locations of point A

4. Conclusions

Based on the conducted simulations, it can be concluded that the stability of the fluger is essential for the proper operation of the entire bomb-fluger system. There was no greater influence of the distance between the fluger mounting point and the bomb mass centre on the dynamics of the entire system for the tested range. It was also observed that the location of the fluger aerodynamic focus has a key impact on its stability and this point should be located at a considerable distance behind the fluger mounting point. The fluger centre mass should be located as close as possible to its mounting point.

References

- [1] Gacek, J., *Balistyka zewnętrzna część I, Modelowanie zjawisk balistyki zewnętrznej i dynamiki lotu*, Wydawnictwo WAT, Warszawa 1999.
- [2] Gacek, J., *Balistyka zewnętrzna część II, Analiza dynamicznych właściwości obiektów w locie*, Wydawnictwo WAT, Warszawa 1999.
- [3] Kowaleczko, G., Buler, W., Pietraszek, M., Klemba, T., *Model matematyczny układu bomba-fluger*, XVIII Ogólnopolska Konferencja Mechanika w Lotnictwie, Kazimierz Dolny 2018.
- [4] Kowaleczko, G., Pietraszek, M., *Estimation of the accuracy of laser guided bomb*, Journal of KONES, Vol. 23, No. 3, pp. 271-279, Warszawa 2016.
- [5] Kowaleczko, G., Pietraszek, M., Olejniczak, E., *Evaluation of the possibility of bomb flight control*, Journal of KONES, Vol. 22, No. 3, pp. 105-116, Warszawa 2015.
- [6] *Sprawozdanie S-14-12/16 Określenie charakterystyk balistycznych lotniczej bomby z układem korekcji lotu, brzechwy trapezowe*, ITWL, Warszawa 2016.
- [7] *Sprawozdanie z realizacji pracy naukowo-badawczej nr PBN/03-084/2017/WAT, Badania doświadczalne w tunelu aerodynamicznym charakterystyk aerodynamicznych modelu bomby lotniczej z układem korekcji lotu*, WAT, Warszawa 2017.
- [8] Winczura, Z., Żyluk, A., *Metoda wyznaczania warunków początkowych swobodnego lotu bomby*, VIII Ogólnopolska Konferencja Mechanika w Lotnictwie, Warszawa 1998.

Manuscript received 19 July 2018; approved for printing 23 September 2018

