

PRZEMYSŁAW SKOTNICZNY\*

**TRANSIENT STATES IN THE FLOW OF THE AIR-METHANE MIXTURE AT THE LONGWALL  
OUTLET, INDUCED BY A SUDDEN METHANE OUTFLOW****STANY PRZEJŚCIOWE W PRZEPLYWIE MIESZANINY POWIETRZNO-METANOWEJ NA WYLOCIE  
ZE ŚCIANY WYWOŁANE NAGŁYM WYPŁYWEM METANU**

The paper discusses the results of the numerical simulation of a sudden outflow of the air-methane mixture from behind a powered support, for a longwall ventilated by means of the U-type ventilation system. The calculations were performed using the geometrical model of an actual longwall – the I 100 longwall at the „Sośnica” hard coal mine. The steady state of the air flow in the area of the upper corner was discussed, together with the phenomenon of methane seepage from the goaf area in the vicinity of the longwall outlet. Subsequently, the phenomenon of a sudden methane outflow – followed by the ventilation of headings – was introduced into the study. The obtained results confirm the knowledge provided by the mining practice and experience.

**Keywords:** sudden methane outflow, powered support, U-type ventilation system

W artykule omówiono wyniki symulacji numerycznej nagłego wypływu mieszaniny powietrzno-metanowej zza obudowy zmechanizowanej w warunkach przewietrzania ściany systemem na „U”. Do celów obliczeniowych posłużono się modelem geometrycznym istniejącej ściany I 100 na KWK „Sośnica”. Omówiono stan ustalony przepływu powietrza w rejonie górnego naroża z uwzględnieniem zjawiska „podbierania” metanu z przestrzeni zrobów w pobliżu wyloty ściany. Następnie wprowadzono zjawisko nagłego wypływu po którym nastąpiła faza przewietrzania wyrobisk. Uzyskane wyniki są zgodne z praktyką i doświadczeniem górniczym.

**Słowa kluczowe:** nagły wypływ metanu, obudowa zmechanizowana, system przewietrzania na „U”

## 1. Introduction

Ventilating longwall headings – especially by means of the U-type ventilation system – involves a risk of an occurrence of disruptions in the work of a longwall. This may happen when the

\* STRATA MECHANICS RESEARCH INSTITUTE OF THE POLISH ACADEMY OF SCIENCES, UL. REYMONTA 27, 30-059 KRAKÓW, POLAND. E-Mail: [skotnicz@img-pan.krakow.pl](mailto:skotnicz@img-pan.krakow.pl)

concentration of methane in the circulating current exceeds the permissible value (Cybulski et al., 2008; Krause & Łukowicz, 2009). The problem of unfavorable methane concentration concerns mostly the area of the longwall's upper corner (Branny, 2006; Krawczyk & Wasilewski, 2009; Dziurzyński & Krause, 2012), where – due to the natural spatial shaping of the longwall area headings and the specific gradient of static pressure caused by the air flow – the concentration of the accumulated methane may even reach 10 percent.

In order to eliminate this phenomenon, undesirable from the perspective of the safety of exploitation, specialists apply a number of methods, generally successful in containing the migration of the concentrated methane to the top heading area (Krause, 2009; Szlązak & Kubaczka, 2012; Skotniczyny, 2013). Such actions – including maintaining a fragment of a top heading behind the caving line, barring the upper corner with a ventilation curtain, methane drainage, or supplying fresh air into the circulating current by means of a ventilation pipe – are effective when the flow of the air-methane mixture in the circulating current is steady. However, the equilibrium in the process of mass exchange between the rock mass and the free flow in the upper corner area may be disturbed. These are transient states, which can effectively increase methane concentrations so that they exceed the safe value range.

The paper presents the results of a three-dimensional simulation of a steady state of the air-methane mixture flow, as well as of a transient state involving a sudden outflow of a 30 percent air-methane mixture from behind a powered support. The study was based on a model of an actual longwall – the I 100 longwall at the „Sośnica” hard coal mine.

## 2. Geometry

The first step in the numerical analysis is constructing a geometrical model that would constitute the computational domain. During the construction process, one should pay attention to proper imaging of details that could influence the results of the simulation of the fluid flow in the designed domain.

The case presented in this article is based on the data found in the technical documentation of the I 100 longwall, obtained from the mine authorities. The data was used to construct a numerical model of this particular area of the upper corner which was of interest to the author, together with the adjacent headings (Fig. 1). Fig. 2 presents the outline of the model in question, as well as the most important dimensions of the discussed object.

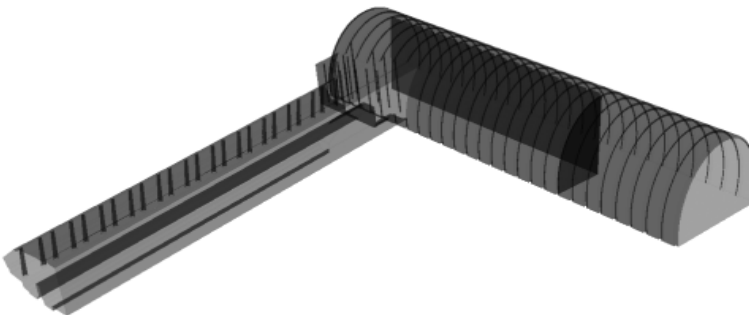

Fig. 1. A general view of the model of the upper corner area, with headings

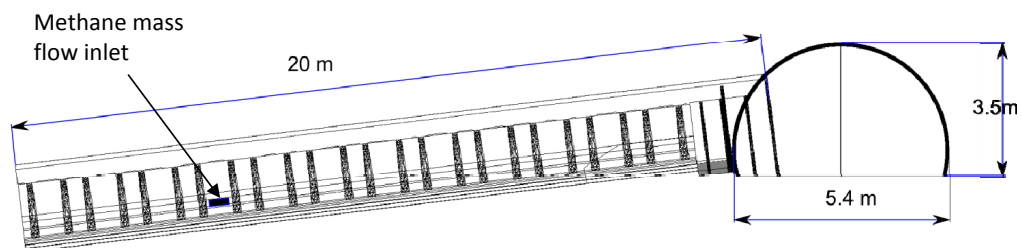

Fig. 2. The main dimensions of the upper corner area model

The designed area encompassed a fragment of the longwall channel, together with the upper corner, and a 20 m long fragment of the top heading. An important characteristic of the discussed geometrical model was the presence of brackets in the temporary support, located in the upper corner area. The ventilation curtain in the top heading, shown in Fig. 1, was placed 3 m away from the „cap”. Its length was 10 m.

The channel of the I 100 longwall was set out within a powered support of the TAGOR 22/46-POz type, whose scheme was presented in Fig. 3. The same figure shows the cross-section of the numerical model of the longwall channel with its support, adapted to numerical computation.

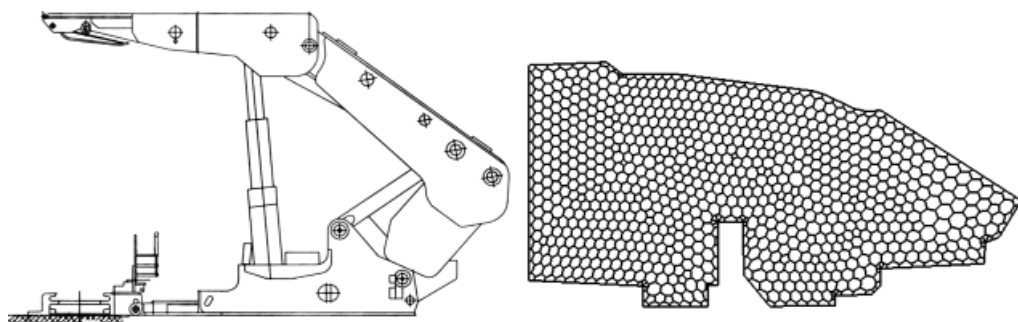

Fig. 3. A fragment of the Tagor 22/46-POz support and its numerical representation

The geometrical imaging – concerning both the construction details of the powered support and the arch support of the top heading, as well as the conveyor drive built into the longwall channel – was optimized with respect to the efficiency of the computation process. The idea was to consider only those fragments that could have a direct impact on the velocity profiles, or the profiles of the concentrations of the air-methane mixture.

The designed numerical model was subsequently digitized by means of a computational grid. Initially, an unstructured grid of the *tri-pave* type, with 1,200,000 elements, was used. However, due to substantial differences in length scales observed in the flow (the field of the cross-section of the longwall heading was much larger than the field of the props of the temporary casing located at the longwall outlet), numerous mistakes, related to the grid quality, were generated. In the case of determining the flow parameters of a multicomponent mixture, even minor flaws in

the designed computational grid may cause instability of the computation process, or even make it impossible to obtain a solution (the solution is divergent).

As far as the discussed case is concerned, it was necessary to adopt a certain procedure existing within the FLUENT solver, i.e. the procedure of replacing the damaged elements in a *tri-pave* grid with polyhedral elements of the hexahedral type. Thus, all the faulty elements were eliminated from the grid. A fragment of the cross-section of the longwall channel with the plotted hexahedral-type grid was shown in Fig. 3, right next to the powered support scheme.

### 3. Boundary conditions

The discussed computational case was considered under isothermal conditions. The modeled flow was a multicomponent one (the air-methane mixture with full multicomponent diffusion and buoyancy). Due to the peculiar characteristics of the case in question, both the inlet and the outlet of the computational domain were attributed with specific pressure-type conditions: pressure inlet and pressure outlet, respectively. An additional boundary condition – responsible for supplying methane of 30% concentration into the longwall channel area – was a mass-type condition (mass-flow inlet). Its location was presented in Fig. 2. The distance between the source of methane and the cross-section of the outlet longwall channel was 12 m. Additionally, in the outlet cross-section of the longwall, on the side of the direct caving, a passive methane source – understood as a wall-type boundary condition – was located. The methane concentration in this passive source was 20%. This was done in order to represent the actual conditions as best as possible. Also, the aim of the operation in question was to simulate an actual phenomenon involving the diffusional methane seepage from the end of the longwall not sheltered by the powered support, on the side of the direct caving.

The computation process was conducted in three stages. In the first stage, the aim was to reach a state of equilibrium involving a quasi-constant distribution of the air velocity values in the longwall channel, as well as a steady, diffusional mixing of the air stream and the 20% mixture from the previously defined passive methane source.

In the next stage, after reaching the desired state of equilibrium, the active methane source was activated. The source supplied the 30% air-methane mixture for 60 seconds. The amount of the mixture supplied was  $1 \text{ m}^3/\text{s}$ .

The final stage involved performing a simulation of the process of ventilating the upper corner area after a sudden appearance of the air-methane mixture behind a powered support.

The sections below present the most important results of the consecutive computational stages.

### 4. Results

The subsequent subsections of the paper present the results of the simulation of the discussed case, according to the three stages corresponding to the dominant flow phenomena: the steady state, a sudden outflow of the air-methane mixture, the process of ventilating the headings.

#### 4.1. The steady state

This subsection presents the selected results of the simulation of the air-methane mixture flow in the so-called „steady state”. Fig. 4 presents the selected time instants of the simulation in question, for the discussed geometrical model. The cross-sections visible in the longwall channel contain the profiles of the module of the velocity of the air flowing, presented in the color scale, in the range of 0-2 m/s. In the upper corner area, there are isosurfaces of the distribution of methane concentrations, presented in the color scale, in the range of 0-30%.

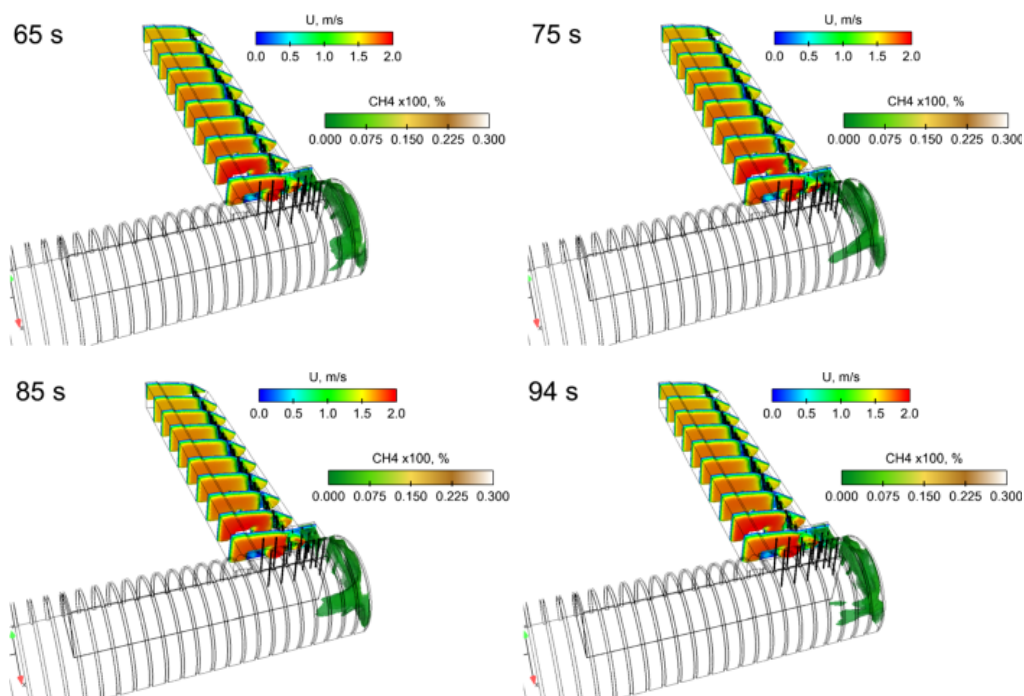

Fig. 4. Selected time instants of the air-methane mixture flow; the „steady state”

On analyzing the distributions of methane concentrations in the upper corner area, one can observe that the methane occurring in the area filled with individual props, on the side of the direct caving, was „sucked”, and it was migrating tangent to the „cap” plane, into the top heading. The maximum value of the methane concentration in the vicinity of the left sidewall (looking from the perspective of the longwall outlet) did not exceed 1%. The low methane concentration in the top heading area was due to the proper functioning of the ventilation curtain. The curtain directed the air stream flowing out of the longwall, and effectively diluted the methane migrating from the area of the direct caving.

The effectiveness with which methane was diluted in the vicinity of the „cap” is best visible in Fig. 5, which presents the isosurfaces of the distribution of methane concentrations for the four different values: 0.6, 1, 2, and 5% CH<sub>4</sub>.

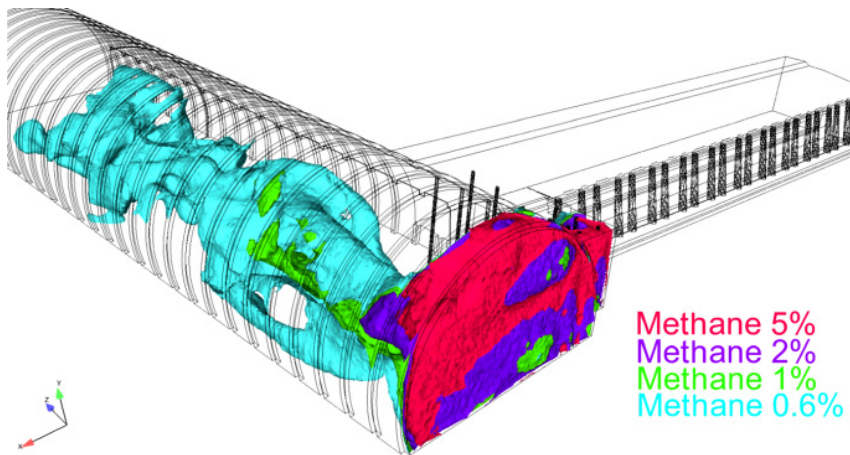

Fig. 5. The isosurfaces of the distribution of methane concentrations on the „cap”

The high values of methane concentration (ca. 5%) occur only in the close vicinity of the „cap” plane. The circulating air dilutes the mixture. As a result, the concentration is 0.6%  $\text{CH}_4$ , which does not pose a safety threat. The range of occurrence of the alarm level concentration values does not exceed the distance of 0.5 m from the „cap” plane.

#### 4.2. The transient state – a sudden methane outflow

Considering the stability and the time that obtaining a numerical solution takes, it needs to be stated that the untimely introduction of an additional factor – a source member – to the undeveloped flow could considerably lengthen the time needed to get the solution. In the discussed case, after analyzing the steady state, it was decided that the sufficient stability of the solution had been ensured by the time instant  $t = 45$  s. This instant marks the beginning of the second stage – the stage of a sudden methane outflow.

The results of the simulation of the discussed phenomenon were presented in Fig. 6.

One of the characteristics of the methane flow in the longwall channel, right from the start of the occurrence, was substantial consistency in the distribution of concentrations. Particular time instants shown in Figure 6 indicate that the advective transportation of the cloud of the released methane towards the longwall outlet dominates over the diffusional mixing of methane. The effective dilution of the methane cloud, coherent as regards the distribution of concentrations, takes place only after it has gotten close to the longwall inlet, in the area of the temporary support. The presence of these elements results in further distortions in the flow, which, in turn, increases the effectiveness of the turbulent mixing of air and methane streams. An additional factor that accelerates this phenomenon is the change in the angular momentum of the air stream in the upper corner.

A phenomenon which is quite disturbing in the aspect of the mining safety is the accumulation (in the closed area of the ventilation curtain) of the mixture whose concentration is between 2 and 5%. Consecutive time instants in Fig. 6 show that, in the roof layers in the curtain area, the volume of the mixture characterized by unacceptable concentration values increases sys-

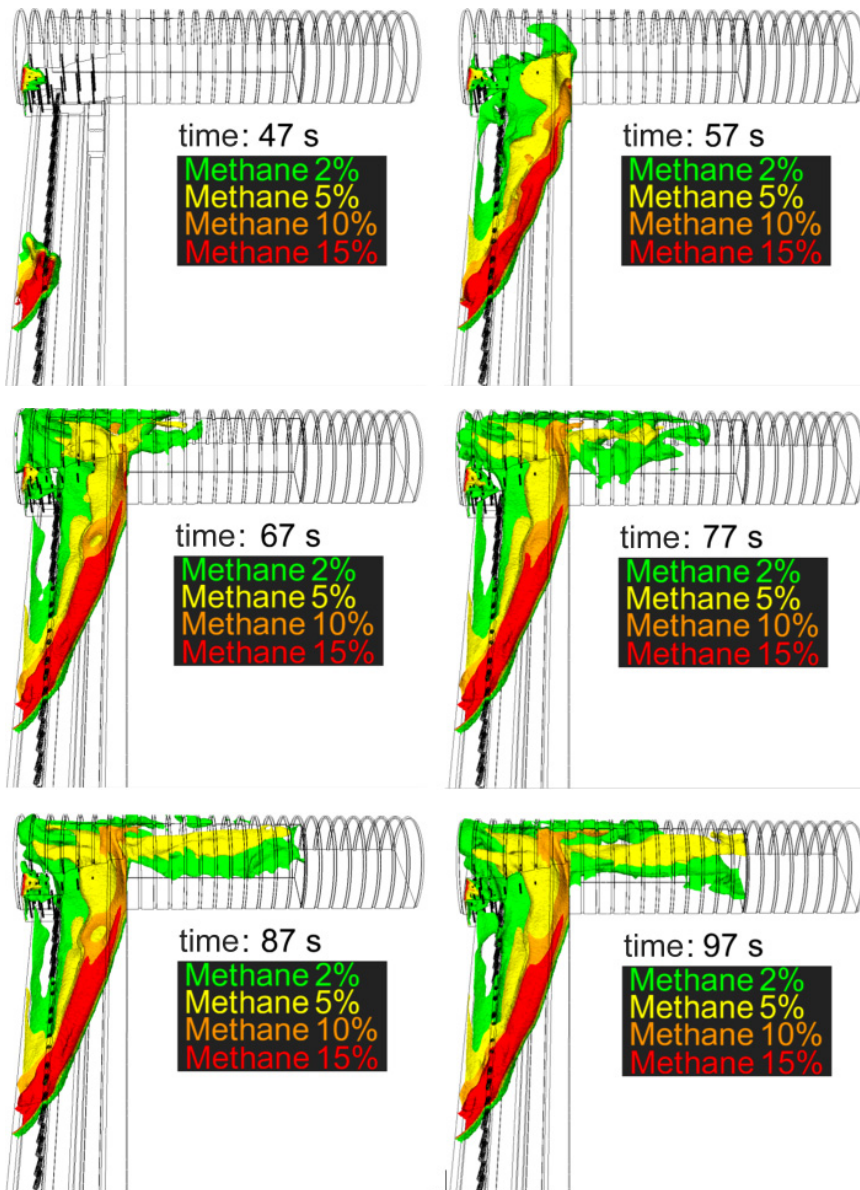

Fig. 6. Selected time instants of a sudden air-methane mixture outflow

tematically. Under real-world conditions, this threat could look slightly different, due to lower leaktightness of the ventilation curtain. Nevertheless, the mechanism of the propagation of the air-methane mixture will be the same.

When performing the discussed computations, a simultaneous test was carried out with the simulation of the functioning of the system for monitoring methane concentration. To this end,

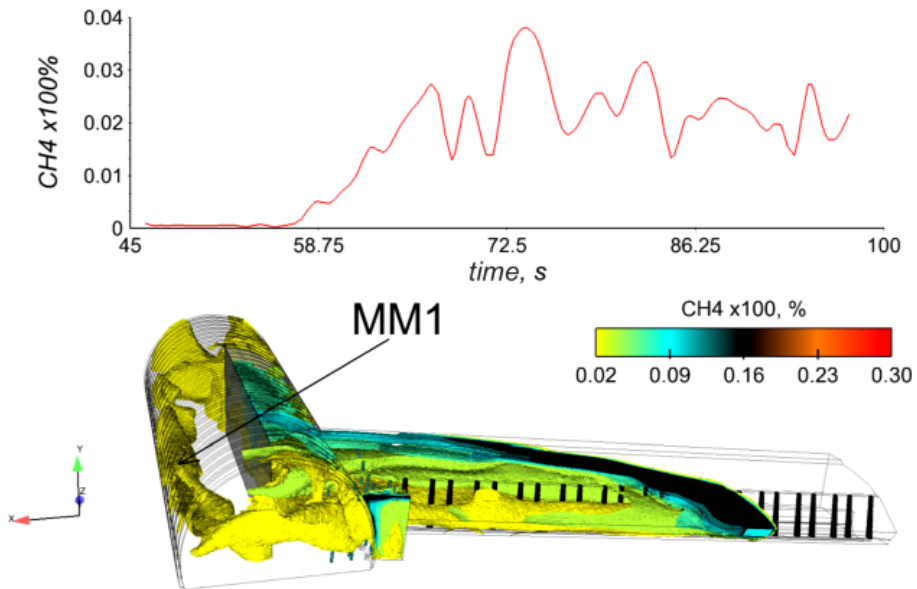

Fig. 7. The location and registration of a virtual methane meter – MM1

in the area of the top heading, 2 m away from the „cap” plane and at the height of 1.6m on the side of the left sidewall, a virtual methane meter was placed (marked as „MM1” in Fig. 7). Its readings were then carefully observed during the consecutive steps of the simulation of a sudden outflow of the air-methane mixture from behind the powered support. Fig. 7 presents a curve showing the concentrations of the MM1 methane meter from the start of the occurrence (i.e. the sudden outflow). Changes in the concentration values were registered at the frequency of 1 Hz. The variability of the readings of a virtual instrument corresponds to the general observations. Therefore, the method might prove interesting when it comes to the process of optimizing the distribution of actual sensors, functioning as part of a mine monitoring system.

### 4.3. The non-steady state – ventilating the upper corner

The last time instant in the simulation of the sudden outflow was  $t = 105$  s, after which the final stage – ventilating the upper corner area – began. The dynamics of the propagation of methane, observed in previously discussed stages, indicated a very short time of ventilation of the upper corner area, accompanied by a lack of activity of the source of methane behind the powered support. Indeed, due to the absence of methane supply from behind the support, the high concentration values (15% and more) are quickly reduced. In the upper corner area, the familiar methane seepage from the direct caving area can be observed (cf. the first stage). It could not be discerned before due to high concentrations of methane from the second stage.

However, a phenomenon that was observed before, involving the accumulation of methane characterized by unacceptable concentration values in roof layers, in the area of the ventilation curtain, prevents us from obtaining a steady state like the one from the first stage of the discussed



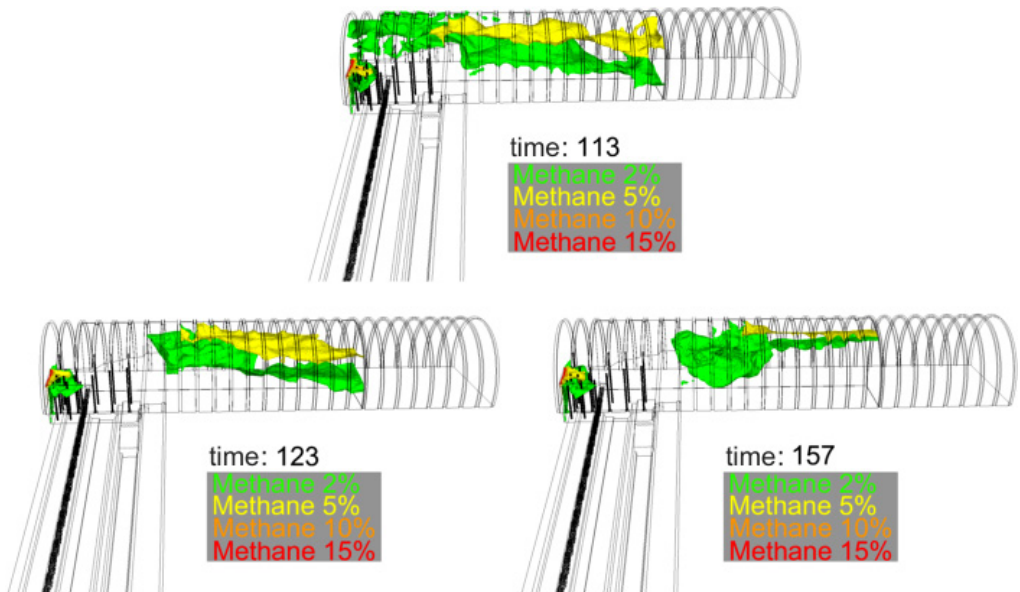

Fig. 8. Selected temporal instants in the process of ventilating the upper corner area

case. Insufficient effectiveness of the ventilation process in the area of the ventilation curtain makes it impossible to dilute the methane accumulated during the second stage. As far as the discussed case is concerned, the reason behind this phenomenon is the fact that the construction of the curtain is too hermetic, and, as such, it blocks the transportation of air masses tangent to the axis of the top heading, in the direction of the outflow from the heading. In fact, even the most carefully designed ventilation curtain will be characterized by some leaks, which – due to the possibility of mass exchange in the area of the top heading – will make it possible to reduce the concentration of the accumulated methane.

Still, it needs to be remembered that – in the case of the absence of a ventilation curtain in the top heading – the time necessary to obtain a normal methane concentration will be much longer than the time of ventilation.

## 5. Conclusions

On analyzing the results of numerical simulations of the process of ventilating the upper corner of the I 100 longwall, discussed in the present paper, the following conclusions can be drawn:

Due to the specific distributions of the velocity of the air flow in cross-sections of the top heading, behind the ventilation curtain, the concentration values of methane in the vicinity of the left sidewall are higher than in the vicinity of the curtain wall;

The phenomenon of a sudden methane outflow from behind the powered support – in the discussed case – is characterized by a high degree of consistency and layering of the methane concentration distribution in the area of the longwall heading. The advective transportation

of the cloud of the mixture dominates over the diffusional mixing of methane with the stream of fresh air;

The observed flow of the cloud of the released methane is not tangent to the heading axis. The aberration from the direction of the tangent is most probably caused by the component of the velocity normal to the heading axis in the X-Z plane. Another reason is the existence of buoyancy forces, which are the source of the velocity component in the Y-Z plane;

The area of the effective dilution of methane layers is the area of the longwall outlet, where – due to the presence of a temporal support – the significance of the turbulent mixing of the air stream and released methane increases;

Introduction of virtual methane meters into the area of headings, performed during the simulation process, might prove helpful in optimizing the choice of locations for actual sensors functioning as part of the mine telemetry system;

The process of ventilating the headings and the upper corner area lasted ca. 23 seconds, measured from the end of the activity of the sudden outflow source;

The process of ventilating the discussed geometrical model was disrupted by the presence of a leaktight ventilation curtain, which stopped the effective mass exchange between the curtain area and the top heading.

Generally, it can be assumed that the discussed results are compatible with observations and mining practice.

The paper was prepared as part of the Strategic Project Task 8 entitled “*Development of a gasometric system causing immediate disconnection of power supplying machinery and equipment in the case of sudden methane outflow from goafs to operational workings*”.

## References

- Branny M., 2006. *Computer Simulation of Flow of Air and Methane Mixture in the Longwall – Return Crossing Zone*. Arch. Min. Sci., Vol. 51, No 1, p. 133-145.
- Dziurzyński W., Krause E., 2012. *Influence of the Field of Aerodynamic Potentials and Surroundings of Goaf on Methane Hazard in Longwall N-12 in Seam 329/1, 329/1-2 in “Krupiński” Coal Mine*. Arch. Min. Sci., Vol. 57, No 4, p. 819-830.
- Krawczyk J., Wasilewski S., 2009. *Migration of Methane into Longwall and Tailgate Crossing*. Proceedings of the Ninth International Mine ventilation Congress, India, p. 483-493.
- Cybulski K., Krause E., Wierzbński K., 2008. *Modelling of methane concentration distribution in region of ventilation roadway crossing with longwall*. Proc. of the 21st World Mining Congress, Underground Mine Environment, p. 29-40.
- Krause E., Łukowicz K., 2009. *Wpływ struktury kopalnianej sieci wentylacyjnej na skuteczność ujęcia metanu*. Prace Naukowe GIG Górnictwo i Środowisko, s. 95-108.
- Krause E., 2009. *Ocena i zwalczanie zagrożenia metanowego w kopalniach węgla kamiennego*. Praca habilitacyjna. Główny Instytut Górnictwa, Katowice.
- Szlązak N., Kubaczka C. 2012. *Impact of coal output concentration on methane emission to longwall faces*. Arch. Min. Sci., Vol. 57, No 1, p. 3-21.
- Skotniczyn P., 2013. *Three-dimensional numerical simulation for the mass exchange between longwall headings and goafs, in the presence of methane drainage in a U-type ventilated longwall*. Arch. Min. Sci., Vol. 58, No 3, p.705-718.

Received: 12 May 2014