



# Polymetallic Concretions – Long-Range Source of Mineral Raw Materials

Tomasz NIEDOBA<sup>1)</sup>

<sup>1)</sup> Assoc. Prof. Eng.; AGH University of Science and Technology, Faculty of Mining and Geoengineering, Department of Environmental Engineering and Mineral Processing, Mickiewicza 30, 30-059 Krakow, Poland; email: tniedoba@agh.edu.pl

## Summary

*In time when traditional resources of mineral raw materials are getting low in many locations on land, polymetallic concretions are interesting alternative for them. They are usually oval agglomerations of many elements, mainly containing iron and manganese. They can be found usually in oceanic depths on 3000-5000 m below sea level depth, mainly in Pacific Ocean basin. The paper presents the genesis of concretions, their main locations of occurring and conditions concerning their potential extraction. The potential benefits occurring from their exploitation were presented. Furthermore, the ways of their extraction with evaluation of the applicability of certain methods were discussed. The actual law situation connected with concretions exploitation with historical background was presented too. The possibilities of Poland in this range concerning extraction of concretions and its share in investigations were evaluated. Poland has the allotment in Clarion-Clipperton area which was presented in the paper with discussion over the research conducted by the organization called Interoceanmetal.*

*Keywords: polymetallic concretions, ocean depths, mineral raw materials, trace elements, materials extraction*

## Introduction

It is harder and harder to find deposits of mineral raw materials on land. The proceeding intensification of raw materials extraction is connected with general economic growth causes exhausting of natural resources. It concerns both energetic materials (oil, natural gas, coal, gas-hydrates), mechanogenic materials (sands containing: titanium, tin, gold, platinum, diamonds, gems, corals, amber); chemical materials (salts, sea phosphates) and also polymetallic materials (oxide sea materials, polymetallic concretions, cobalt-carrying incrustations, polymetallic sulphide ores, metal-carrying clays). The topic of the paper are polymetallic concretions.

## Polymetallic concretions

Concretions Fe-Mn are concentrations of concentric alternating layers of iron and manganese oxides (separated by clay minerals layers) being generations of growth [Kotlinski et al., 2004; Mizerski and Szamalek, 2009].

Concretions occur in both salt and sweet waters (salt ones are bigger and richer in minerals). Concretions were found by scientific expedition during four-years trip on corvette HMS “Challenger” in 1872. The route of this ship was presented on Figure 1.

In one of 50 volumes containing results of investigations the singular rocks of regular, oval shape extracted from seabed were described. Their

composition was mainly iron and manganese oxides with addition of clay minerals. This discovery was treated then as oddity and was quickly forgotten.

Finally in years of 60-ies of previous century, from the time when Jacques Piccard and Don Walsh descended in bathyscaph “Trieste” to the Mariana Trench bed the quick development of knowledge about sea started. It occurred that concretions are located on huge areas of Pacific, Indian and Atlantic oceans beds. The example of such concretion was shown on Figure 2.

## Concretions Fe-Mn – construction and composition

Concretions are naturally polymetallic agglomerations of iron and manganese oxides as well clay minerals, containing more than 50 elements of which many occur in amounts bigger than their concentrations on land. They occur almost only on surface of oceanic bed (sometimes immersed in sediment). The photo of such bed covered with concretions was presented on Figure 3.

Mainly, concretions of spherical or oblate forms dominate, containing often more than one core of size 2-12 cm. Usually, they have concentric structure, creating alternating layers of iron and manganese around core, which are separated by layers of clay minerals [Kazmin, 1984; Mizerski and Szamalek, 2009; Morgan, 2000]. The structure of layer was shown on Figure 4.

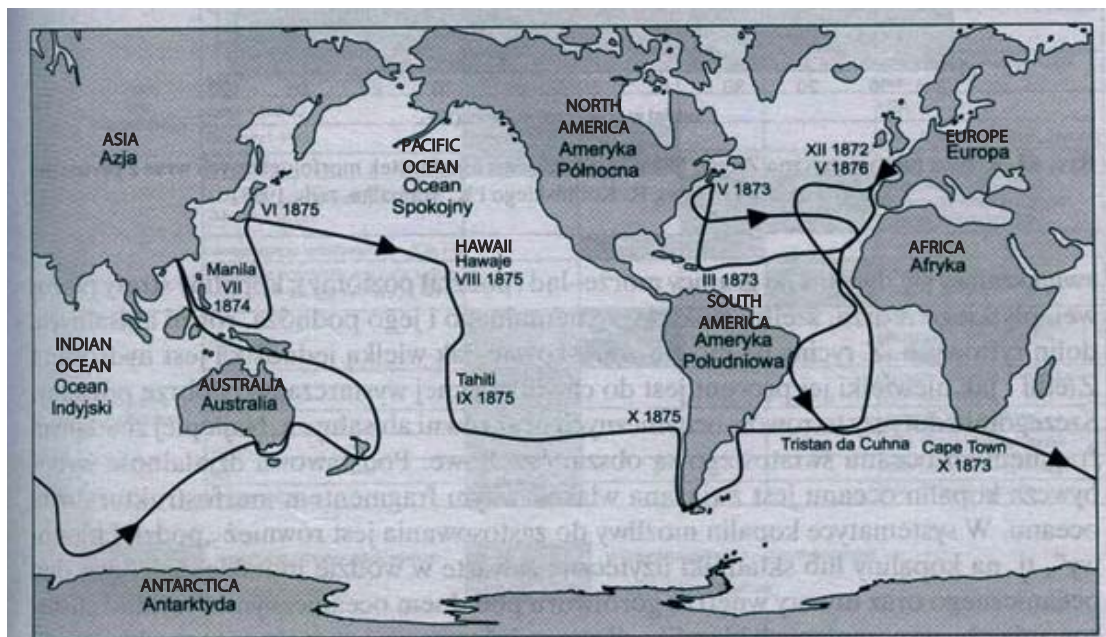

Fig. 1. of corvette HMS “Challenger”, source: Mizerski and Szamalek, 2009

Rys. 1. Szkic trasy korbety HMS „Challenger”



Fig. 2. Compound concretion with smooth surface, source: Mizerski and Szamalek, 2009

Rys. 2. Konkrecja zrostowa z gładką powierzchnią

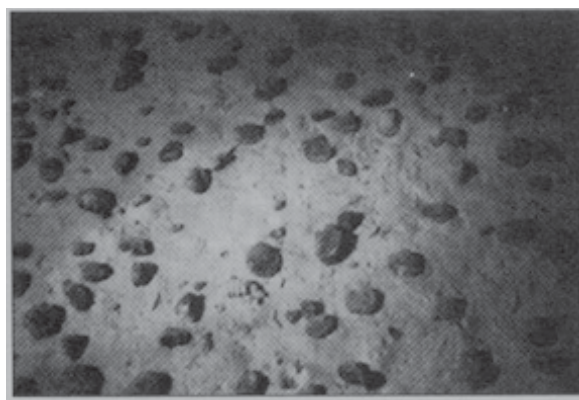

Fig. 3. Photo of oceanic bed covered with concretions, source: Mizerski and Szamalek, 2009

Rys. 3. Zdjęcie dna oceanicznego pokrytego konkrecjami

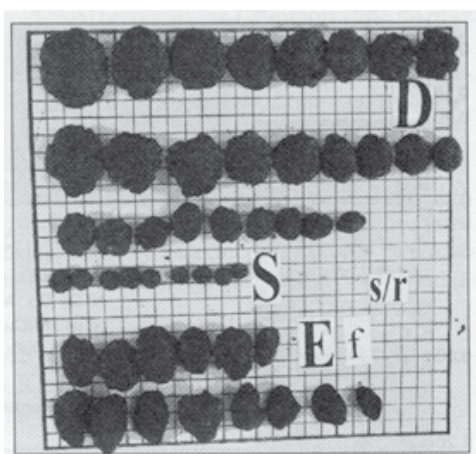

Fig. 6. Example of classification of concretions according to their morphology, source: Mizerski and Szamalek, 2009

Rys. 6. Przykład klasyfikacji konkrecji wg ich morfologii

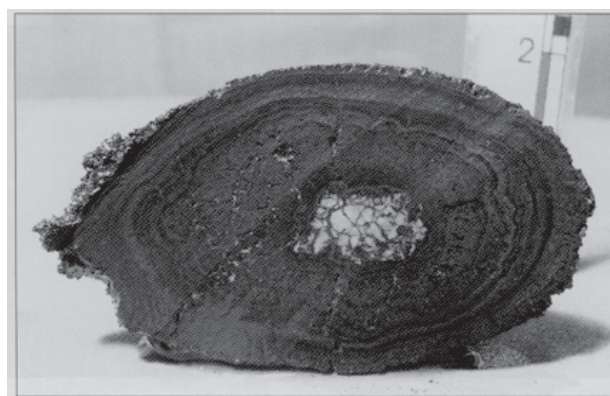

Fig. 4. Layer structure of concretions, source: Mizerski and Szamalek, 2009

Rys. 4. Struktura warstwowa konkrecji

Tab. 1. Mean values of selected elements contents in concretions

Tab. 1. Średnie zawartości wybranych pierwiastków w konkrecjach

Mn	Fe	Si	Al	Co	Ni	Cu	Ti
29%	6%	5%	3%	0.25%	1.4%	1.3%	0.2%

Fig. 5. Morphological classification of concretions, source: Abramowski and Kotlinski, 2011

Rys. 5. Klasyfikacja morfologiczna konkrecji

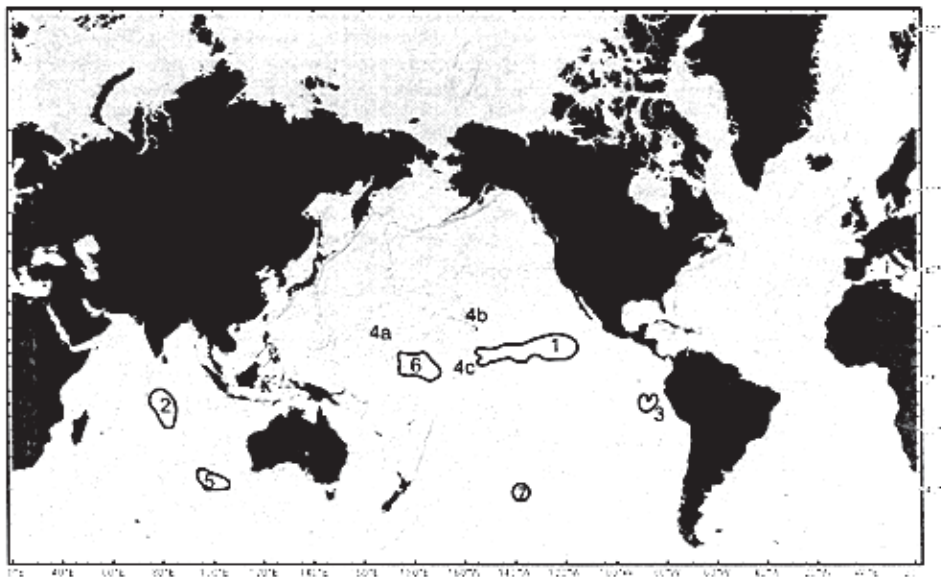
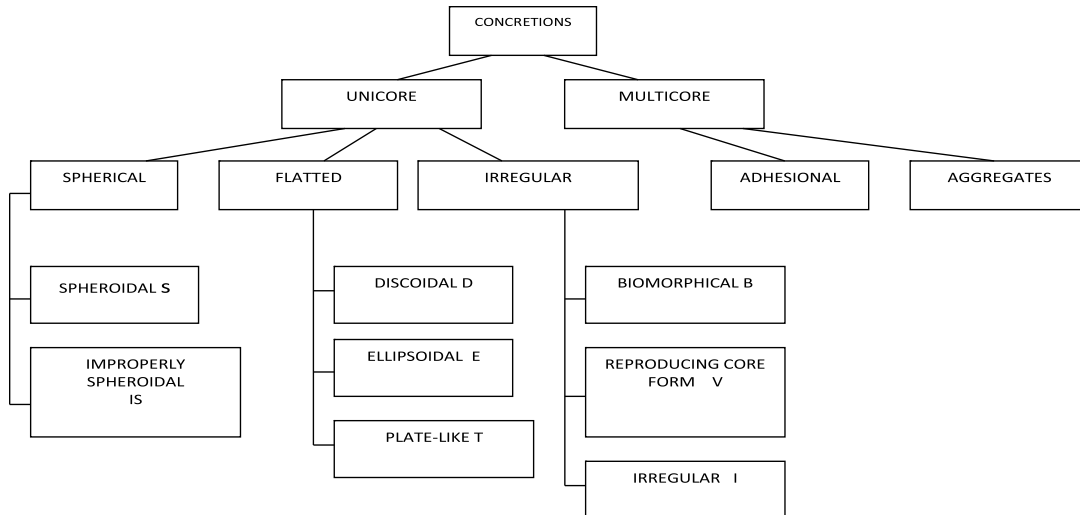

Fig. 7. Long-range concretion fields, source: Abramowski and Kotlinski, 2011

Rys. 7. Perspektywiczne pola konkrecyjonośne

Forms of concretions, particularly in early phases of forming depend on core shape. One of classification is according to their morphology. It was presented on Figure 5.

Concretions are constructed mainly on hydrated iron oxides and hydroxides (ghetite, lepidocrocoite, acageneite, hematite, maghemite) and manganese

oxides and hydroxides (todorokite, birnessite, vernadite, psylomelane, pyrolusite) as well, secondary quartz, feldspars and trace amounts of other minerals.

The mean values of selected elements contents in concretions were shown in Table 1.

The morphological classification is very useful in practice. It serves to classify concretions

Tab. 2. Concentrations of metals in concretions Fe-Mn [Abramowski and Kotlinski, 2011]

Tab. 2. Koncentracje metali w konkrecjach Fe-Mn

Long-range deposits	Metals										
	Mn	Fe	Ni	Cu	Co	Pt	Y	La	Ce	Nd	Pd
	[%]					[p.p.m.]					
Pacific	21.08	11.00	0.80	0.59	0.27	-	344.30	147.80	293.50	151.00	7.20
Clarion-Clipperton, Ni-Co, Ni-Cu—Co3.50	27.20	6.30	1.22	1.02	0.21	0.10	246.00	227.30	392.70	217.30	-
Wake-	19.20	14.50	0.53	0.28	0.42	-	352.00	281.00	1531.000	-	-
Indian Ocean	16.36	14.25	0.39	0.17	0.20	-	62.30	163.30	885.90	3.50	8.70
Central Indian	22.70	9.00	0.93	0.80	0.14	-	-	-	-	-	-

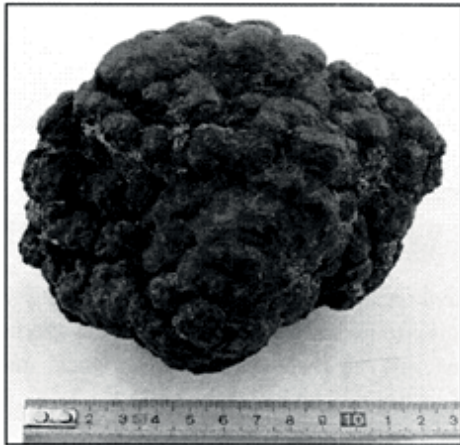

Fig. 8. Polymetallic concretion of cauliflower shape, from Clarion-Clipperton field, source: Zawadzki and Kotlinski, 2011

Rys. 8. Konkrecja polimetaliczna o kształcie kalafiorowatym, z pola Clarion-Clipperton

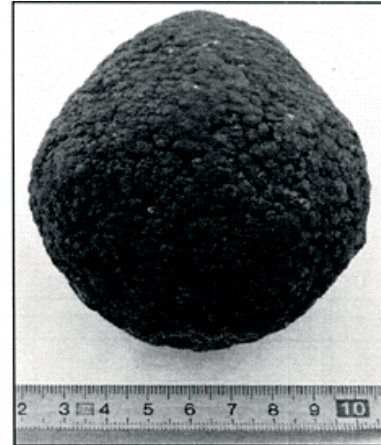

Fig. 9. Spheroidal polymetallic concretion of sculted surface, from Clarion-Clipperton field, source: Zawadzki and Kotlinski, 2011

Rys. 9. Sferoidalna konkrecja polimetaliczna o urzeźbionej powierzchni, z pola Clarion-Clipperton

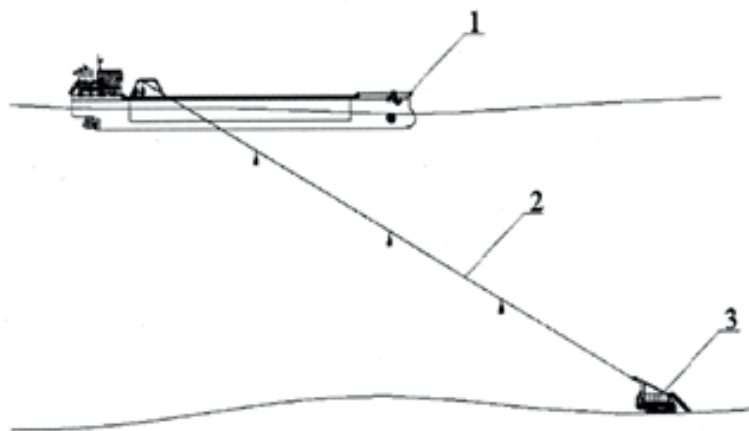

Fig. 10. Systems of extraction complex. 1. Terminal-hold system on the surface; 2. Vertical transport system; 3. Material collecting system, source: Abramowski and Kotlinski, 2011

Rys. 10. Podstawowe systemy kompleksu wydobywczego; 1. System terminalowo-magazynowy na powierzchni; 2. System transportu pionowego; 3. System zbierający kopalinę

directly after their extraction. Samples of concretions after reaching them out on research ship deck are washed, described and segregated according to their shape and size. Example of such classification was shown on Figure 6, basing on data contained on Figure 5.

The most often, concretions are spherical, ellipsoidal or disc, of size 2-12 cm. It is worthy to mention that there are at least several more criterions of concretions classification.

#### **Concretions Fe-Mn – location and conditions**

Concretions Fe-Mn occur on various depths but the their biggest documented concentrations are on depth of 3500-6000 below sea level in abyssal basins of Pacific and Indian oceans. The depth of concretions occurring and its covering density (concretions contents) are various. For example Clarion-Clipperton field – depth 4200-5200 m below sea level, concretions till 10kg/m<sup>2</sup>; Central Indian Basin – 4500-5600 m below sea level, concretions till 6.94 kg/m<sup>2</sup> [von Stackelberg and Beiersdorf, 1991; von Stackelberg, 2000], .

The concentrations of industrial meaning are limited to some strategic areas of concretions. The most important are (location shown on Figure 7):

- Clarion Clipperton (marked as 1 on the Figure 6);
- Central Indian (2);
- Peruvian (3);
- North-West Pacific Mountains: wake, Necker, Magellan (4a); volcanic arcs: Hawaiian (4b), Line (4c);
- Diamentin (5);
- Central Pacific (6);
- Menard (7).

The average concentrations of selected metals in iron-manganese concretions were presented in Table 2.

The basis of this classification were conditions of backlog, estimated amounts of concretions and their composition and metal contents (Mn, Ni, Cu and Co). It is assumed that mining area should have resources allowing extraction during 20-25 years on level of 1.5-4 million tons of concretions per year by metal contents: 1.25-1.50% of Ni; 1.00-1.40 of Cu; 27.00-30.00% of Mn and 0.20-0.25% of Co [Pienkowski, 2000].

Field Clarion-Clipperton is special among distinguished fields. It has high coefficient of concretion amount (10 kg/m<sup>2</sup>) and highest metals concentration. To compare, the mean contents of metals in ores on land and polymetallic concretions were shown in Table 3 [Pienkowski, 2000]. Examples of concretions shapes are shown on Figures 8-9.

Concentrations of metals in oceanic deposits are similar to their concentrations on land. However, cobalt, nickel and copper contents, having big economic meaning, is higher.

#### **Concretions Fe-Mn – genesis**

Polymetallic concretions occur mainly on areas of abyssal planes and are connected with deposition of manganese and iron and their growth around cores (rock fragments, bone parts, as shark teeth etc.). The presence of cores is extremely important. In case of lack of rock fragments or organic debris, microconcretions can be created in supporting conditions [Zawadzki and Kotlinski, 2011].

Concretions are being created in water environment in which not consolidated sediment as well elementary manganese occur which are transferred to sea from evaporating continental rocks and from undersea volcanoes. Manganese occurs in water in two forms:

Tab. 3. Comparison of percentage contents of chosen metals in ores on land and in area of Clarion-Clipperton field

Tab. 3. Porównanie procentowych zawartości wybranych metali w rudach na lądzie i w obszarze pola Clarion-Clipperton

Metal	In ores on land [%]			Concretion area C-C [%]
	1990	2000	2010	
Nickel	1.80	1.50	1.20	1.10-1.40
Copper	1.60	1.50	1.20	0.95-1.30
Cobalt	0.22	0.20	0.15	0.18-0.21
Manganese	37.00	36.50	35.00	28.50-32.00

- If water environment conditions are reductive, in the solution the stable ions of dissolved divalent manganese Mn(II) are present;
- If water environment conditions are oxidizing, it can dissolve in form of quadrivalent manganese Mn(IV)oxide.

The basic initial condition of creating concretions (dissolving of manganese) is very reduced sedimentation of other particles on the bed and maintaining oxidizing conditions in environment for longer period of time. For example, for Clarion-Clipperton zone, the values of pH<sub>c</sub> (7.24 – 7.61), Eh<sub>c</sub> (+343, +417). The first phase of concretions creating is dissolvent of amorphous iron oxide and hydroxide (ghetite) which creates thin layer supporting dissolvent of manganese oxides on core surface. These processes are multiphase and lead to creation of, usually, 2-3 generations of growth. The surface of manganese oxide is autocatalytic and includes manganese to growth structures as well absorb other metals from sea water very efficiently (for example nickel and copper). The pace of growth of individual mineral generations is various. For example, average growth pace for Pacific concretions is about 2-3 mm/mil-

lions of years, in Central Indian Basin – 1.2 mm/millions of years and on Peruvian field – 160-250 mm/millions of years [Pienkowski, 2000].

### Exploitation of concretions deposits

The most important part of the whole exploitive system is extraction complex which should perform the following tasks:

- Collection of concretions from the ocean bed;
- Extraction of concretions to the ocean surface (to the ship);
- Initial cleaning;
- Periodical storage in ship hold;
- Transfer of concretions to transporting units.

The basic system of extraction of concretions was presented on Figure 10.

Process of extraction is realized by three devices:

- Bed collecting vehicle;
- Extracting installment;
- Flowing extractive unit (ship).

One of the ideas was Jules Verne ship which was presented on Figure 11.

There are also other solutions of extracting systems but generally such system must always perform tasks of collecting and extracting concretions on water surface.

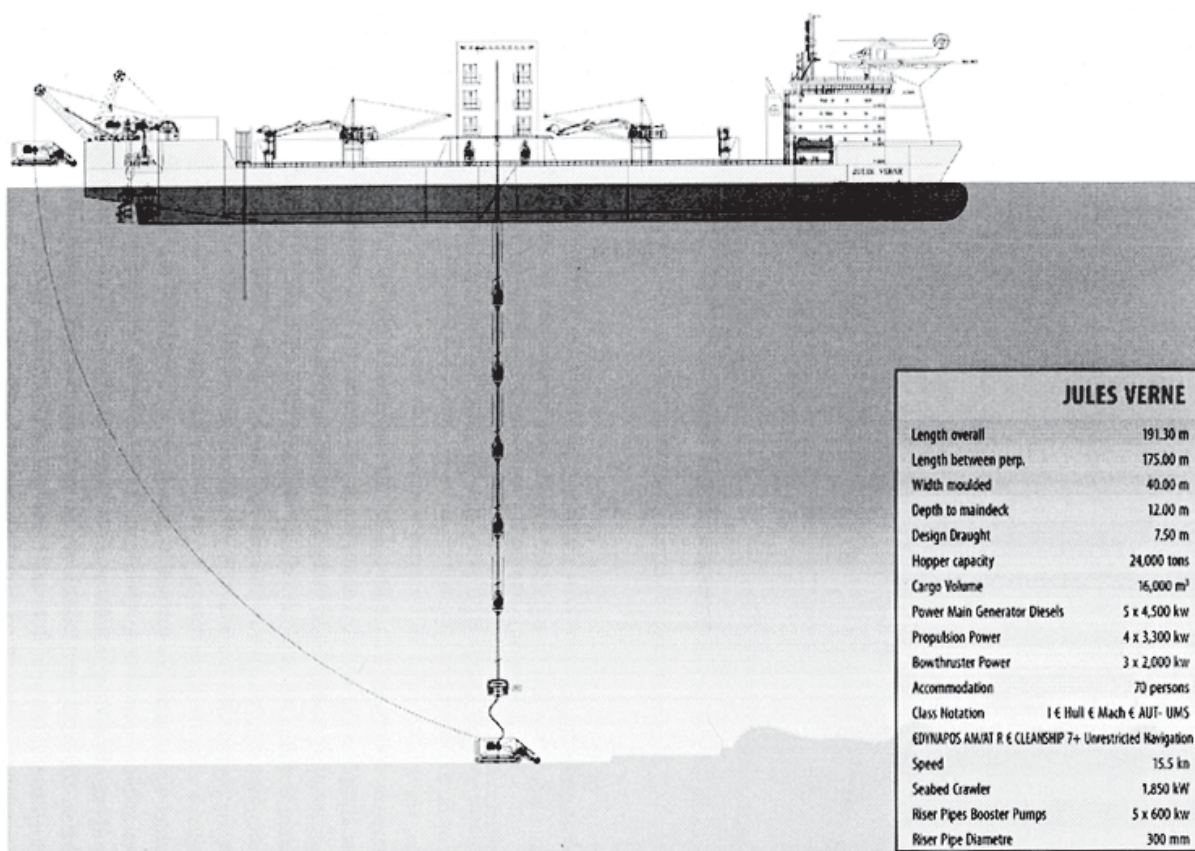

Fig. 11. Concept of extractive ship Jules Verne, hydraulic system of vertical transport, source: Abramowski and Kotlinski, 2011

Rys. 11 Koncepcja statku wydobywczego Jules Verne, hydrauliczny system transportu pionowego

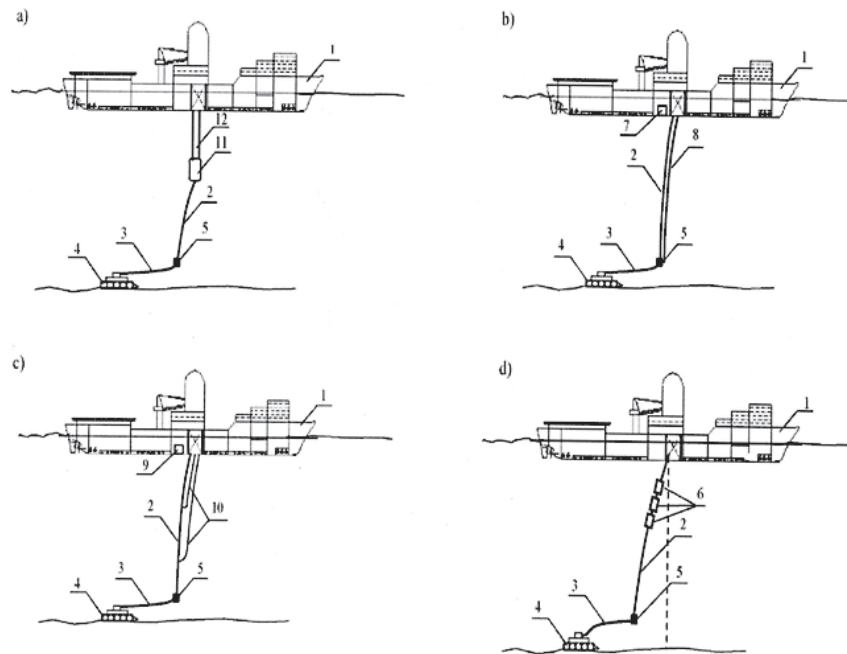

Fig. 12. Examples of hydraulic extractive installments: a) with underwater separation cell; b) two-pipe with pumps on extractive ship board; c) hydraulic-pneumatic; d) one-pipe with depth pumps: 1 – extractive ship; 2 – vertical pipeline; 3 – horizontal, elastic pipeline; 4 – aggregate collecting concretions; 5 – buffer; 6 – depth pumps; 7 – pumps on ship board; 8 – pipeline transferring clean water; 9 – compressors; 10 – pipes supplying compressed air; 11 – underwater separation cell with pumps; 12 – mechanical system of vertical concretions transport, source: Abramowski and Kotlinski, 2011

Rys. 12. Przykłady hydraulicznych instalacji wydobywczych: a) z podwodną komorą separacyjną; b) dwururowa z pompami na pokładzie statku wydobywczego; c) hydrauliczno-pneumatyczna; d) jednorurowa z pompami głębinowymi: 1 – statek wydobywczy; 2 – pionowy rurociąg; 3 – poziomy, elastyczny rurociąg; 4 – agregat zbierający konkretje; 5 – bufor; 6 – pompy głębinowe; 7 – pompy na pokładzie statku; 8 – rurociąg przesyłający czystą wodę; 9 – kompresory; 10 – rury dostarczające sprężone powietrze; 11 – podwodna komora separacyjna z pompami; 12 – mechaniczny system pionowego transportu konkretji

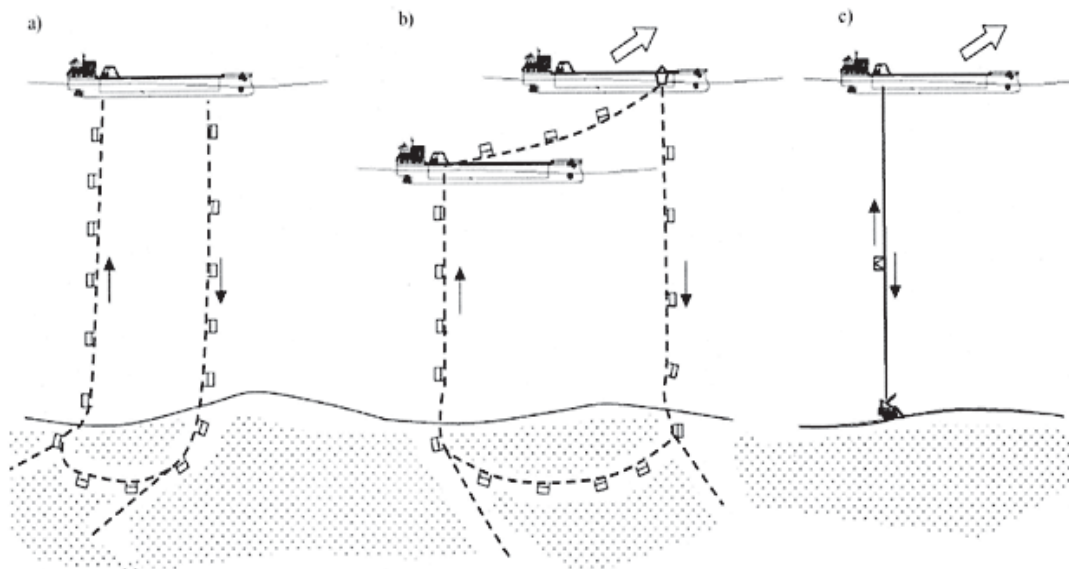

Fig. 13. Examples of mechanical extracting installments: a) Rope-container method with one ship (Japanese version); b) Rope-container methods with two chips (French version); c) Rope-container method with aggregate collecting concretions, source: Abramowski and Szelangiewicz, 2011

Rys. 13. Przykłady mechanicznych instalacji wydobywczych: a) metoda linowo-kubłowa z jednym statkiem (wersja japońska); b) metoda linowo-kubłowa z dwoma statkami (wersja francuska); c) metoda linowo-pojemnikowa z agregatem zbierającym konkretje

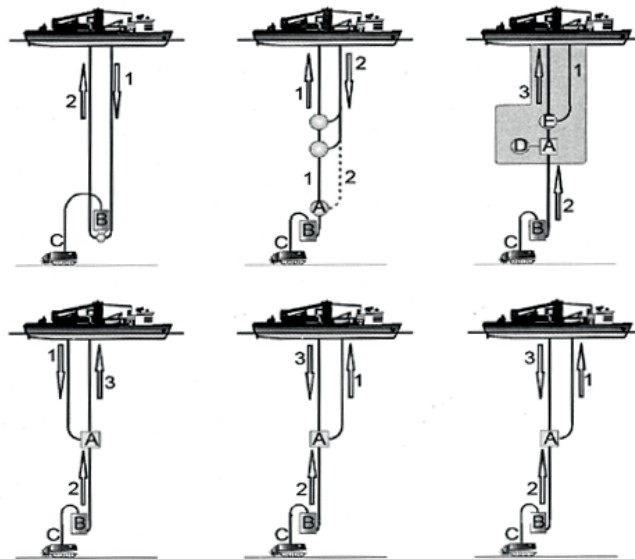

Fig. 14. Concept of vertical transport elaborated by IOM (Interoceanmetal). Six configurations of the system were tested. Markings: A-crusher; B-buffer; C-collecting aggregate; D-dropping pump; E-rising pump, source: Abramowski and Szlangiewicz, 2011

Rys. 14. Koncepcja transportu pionowego opracowana przez IOM. Przetestowano sześć konfiguracji systemu. Oznaczenia: A – rozdrabniacz; B – bufor; C – agregat zbierający; D – pompa zrzutowa; E – pompa podnosząca

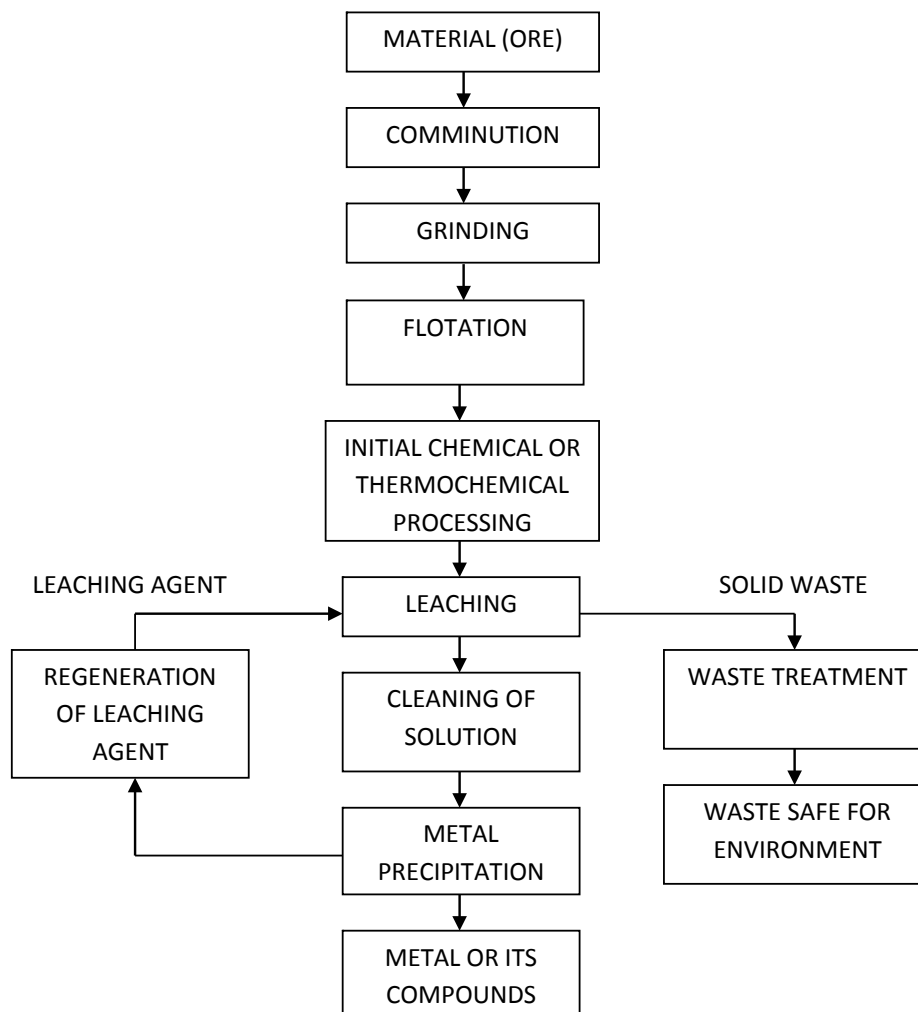

Fig. 16. Operations of hydrometallurgical method of obtaining metals, source: Sanak-Rydlowska and Gala, 2011

Rys. 16. Operacje jednostkowe metody hydrometalurgicznej otrzymywania metali



From the moment of starting investigations in 1970 above possibility of industrial extraction of concretions many extracting methods were elaborated which can be divided into three groups:

- Hydraulic methods (Figure 12);
- Mechanical methods (rope-container) (Figure 13);
- Methods with automatic submersible barges (Figure 14).

In hydraulic methods the extraction of concretions occurs as a result of flow of working factor in extraction pipeline, which is water or water with pressured air. Concretions are transferred to vertical pipeline from collecting aggregate by means of elastic, horizontal pipeline [Abramowski and Kotlinski, 2011].

In hydraulic installments group the most often considered variants are:

- One-pipe with depth pumps (tests were performed on ships “Hughes Gloman Explorer”, “Sedco 445”);
- One-pipe with pressured air (tests were performed on ships “Deepsea Miner” and “Deepsea Miner II”);
- Two-pipe with pumps pressing water placed on extracting ship board;
- One-pipe with underwater separation cell (from this cell concretions can be extracted on the ship by means of mechanical device).

In mechanical methods the extraction of concretions was realized by means of containers attached to scrolling ropes.

In methods with submersible barges concretions are risen from the bed in holds of submersible barges which have to collect concretions by themselves or can be loaded on the bed by means of collecting aggregate [Abramowski and Szelangiewicz, 2011]. The general concept of extractive-transport system was shown on Figure 15.

The task of DEV (depth extracting vehicles) is:

- Collection of concretions from ocean depth;
- Initial cleaning of slimes and sediments;
- Vertical transport on ocean surface;
- Horizontal transport to transporting ship.

The Project assumes that DEV will be controlled automatically, equipped with sort of artificial intelligence allowing to decide immediately. On mining ship the control center will be located (where DEV will transfer information) and repair workbenches. Furthermore, the extracting complex will be equipped with deposit service ship and technical support ship.

Despite that presented proposals of extracting installments, together with their many modifications and types are known for many years there is lack in the world literature of detailed constructive solutions, experiments results with laboratory installments or prototypes or honest theoretical and calculating analyzes. Each of the methods of extracting concretions have its advantages and disadvantages and too little data was published to indicate precisely which of them will be the most reliable and economically efficient. The results

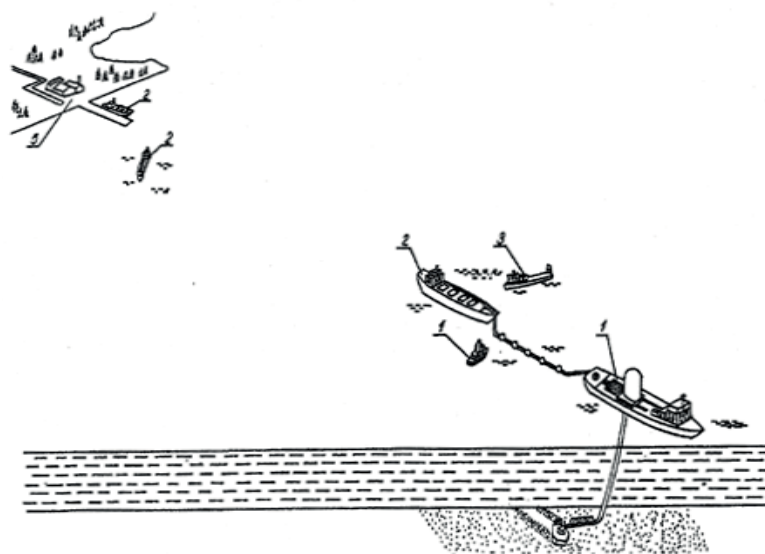

Fig. 15. Extractive-transport system; 1 – extractive complex; 2 – transport ships; 3 – supplying ship; 4 – technical service ship; 5 – land base, source: Abramowski and Szelangiewicz, 2011

Rys. 15 System wydobywczo-transportowy; 1 – kompleks wydobywczy; 2 – statki transportowe; 3 – statek zaopatrzeniowy; 4 – statek obsługi technicznej; 5 – baza lądowa

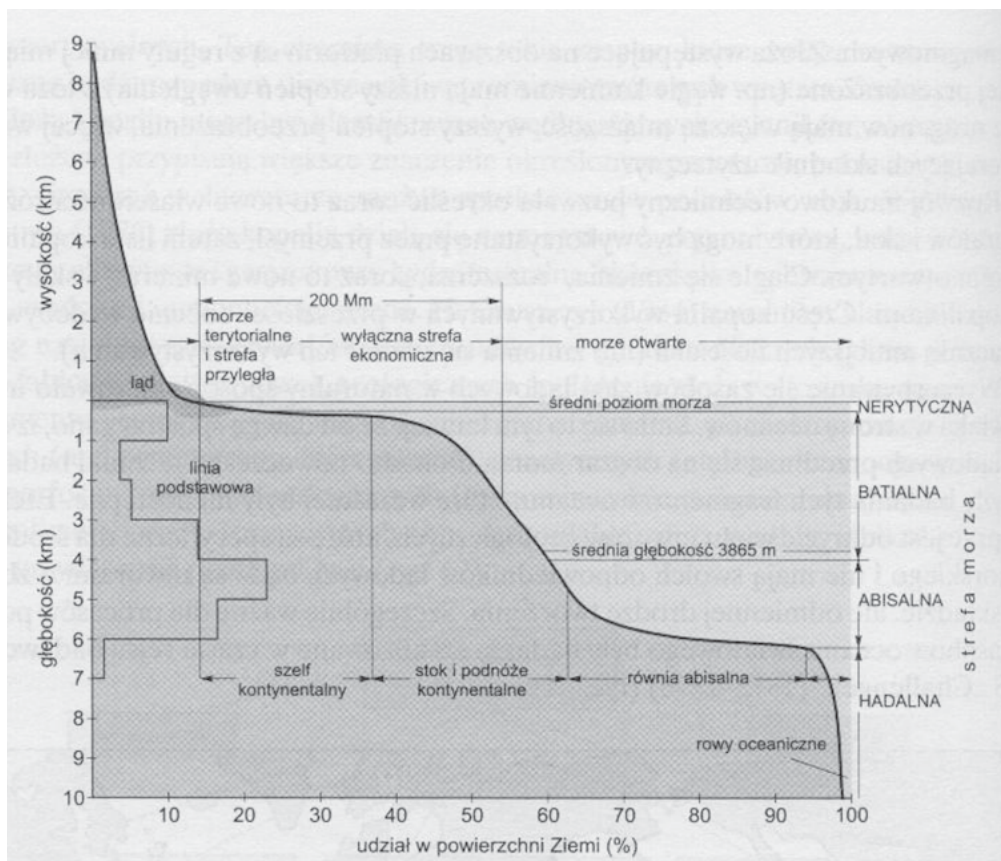

Fig. 17. Hypsometric curve of Earth. Share of individual morphological units with division of world ocean, source: Mizerski and Szamalek, 2009. On Fig. 1. *ś* (km) = height (km); *głębokość* (km) = depth (km); *morze terytorialne i strefa przyległa* = territorial sea; *wyłączna strefa ekonomiczna* = economic zone; *morze otwarte* = open sea; *średni poziom morza* = mean sea level; *ląd* = land; *linia podstawowa* = basic line; *szelf kontynentalny* = continental shelf; *stok i podnóże kontynentalne* = continental slope; *równia abisalna* = abyssal plane; *udział w powierzchni ziemi* = share in Earth surface; *rowy oceaniczne* = oceanic trenches; *średnia głębokość 3865 m* = mean depth 3865 m; *nerytyczna* = neritic; *batialna* = bathyal; *abisalna* = abyssal; *hadalna* = hadal; *strefa morza* = zone of sea.

Rys. 17 Krzywa hipsometryczna Ziemi. Udział podstawowych jednostek morfologicznych wraz z podziałem oceanu światowego

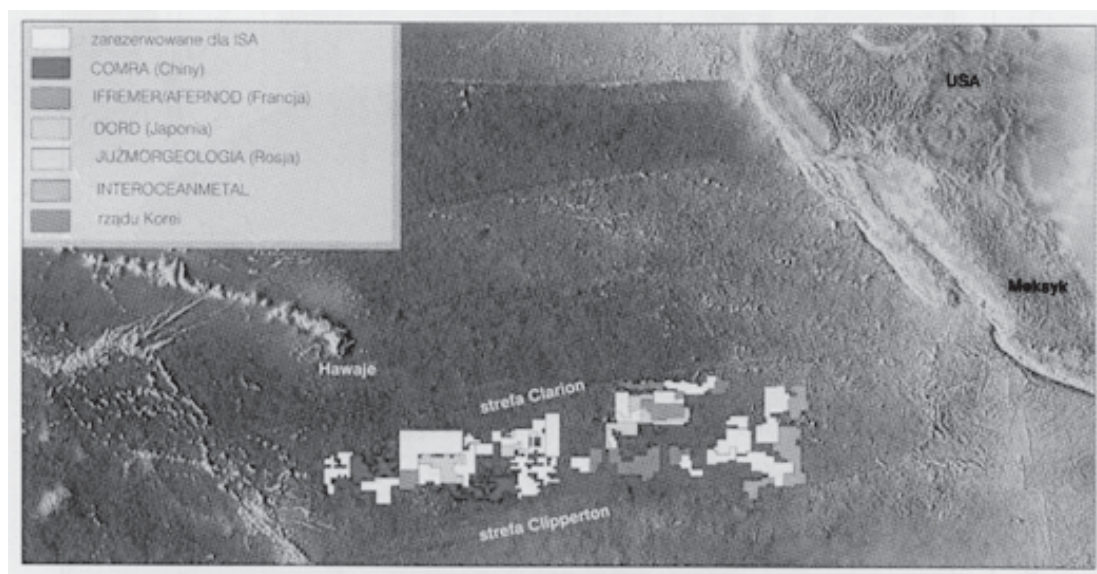

Fig. 18. Location of deposit allotments of concretions Fe-Mn for individual contractors and allotments given to ISA (International Seabed Authority), source: Mizerski and Szamalek, 2009

Rys. 18. Lokalizacja działek złożowych konkrecji Fe-Mn poszczególnych kontraktorów oraz działek przekazanych na rzecz ISA

of actually conducted laboratory works and tests on sea are classified and cannot be used to select appropriate installment and construction of its prototype. It is necessary to conduct theoretical investigations, together with computer modeling of virtual systems to have the possibility of selecting the most efficient and reliable methods to industrial extraction of concretions.

Another problem, after determining what extraction method would be the most efficient and reliable, is determination of designing parameters of devices and whole system on Figure 15 – capacity of concretions extraction, volume of ship hold, number and carrying capacity of transport ships etc. It has to be optimized to ensure the costs of extraction and transport of 1 ton of concretions to be the lowest. In literature the results of such optimizations are presented but unfortunately base on too less credible or too simplified data. In this range the optimizing calculations should be conducted basing on the most precise mathematical models of extracting systems and for more credible data, like economic ones.

#### **Metals recovery from oceanic concretions**

Concretions contain many very rare elements. They create natural concentrations of manganese oxides and hydroxides (till about 30%) and contain traces of other elements, mainly nickel (1.25-1.50%), copper (1.00-1.40%), aluminum (3%) and others. The manganese, copper, nickel and cobalt contents decide about economic value of concretions. One of the important aspects of profitability of extraction apart from exploitation and transport problems of obtained ore on ocean surface is its processing [Sanak-Rydlewska and Gala, 2011].

It occurs from the investigations that the most beneficial for concretions processing will be application of hydrometallurgical methods. Each hydrometallurgical process contains many unit operations. The general scheme was presented on Figure 16.

Some simplification in application of these methods is facility of concretions crushing in dry conditions what allows to liberate useful minerals from gangue to particle size distribution necessary in leaching processes. Further technological operations should contain application of known chemical technologies allowing selective or collective assignation of appropriate metal forms. In case of very low concentrations of metal (or metals) in solution the concentrating methods should be used and then such methods as extraction, electrolysis or precipitation.

#### **Metallic concretions – law determinants**

##### **General background**

Even from ancient times the problem of owing individual parts of world seas and oceans occurred (Cartagina, Rome – control on Mediterranean Sea shore). From XVII century the doctrine of free ocean was applied (being property of all nations).

– 1609 – Hugo Grotius proclaimed the Treaty “Mare Liberum” limiting laws of waterside countries only to narrow area of shore zone with possibility of its widening by application of “force law”;

– Little bit later the range of cannon shot decided about control and application of waterside country law;

– First measurement of cannon shot range was performed in 1772 by British which wanted to control area of sea of width of 3 sea miles;

– In 1945 the decision of USA President Harry Truman was made which considered mineral resources on continental shelf of USA as being only under American jurisdiction. Similar decisions were made by other countries, like:

- 1946 – Argentina (inner sea and shelf);
- 1947 – Peru and Chile;
- 1950 – Ecuador (200 sea miles of shore zone).

A little bit later – Egypt, Ethiopia, Saudi Arabia, Libya, Venezuela, Norway, Indonesia and Eastern Europe countries – zones of territorial sea of width of 12 sea miles.

In 1947 on international forum the initiative of creating Commission of International Law was made which supposed to prepare important materials for UN in purpose of codification of the sea law. In 1958-1982 three conferences of sea law were organized (UNCLOS – United Nations Conference of the Law of the Sea). The successful one was third conference lasting for 9 years from 1973 till 1982.

On 10 December of 1982 in Montego Bay in Jamaica, 119 countries signed final act of third Sea Law Conference confirming creation of International Law of Sea.

Till 1994 there were discussions concerning XI part of the International Law of Sea about “Area” which is open ocean outside national jurisdictions.

On 24 of July of 1994 in New York, 40 countries (including Poland) signed agreement about implementation of XI part of International Law of Sea in form of annex. Formally, Poland became the side of International Law of Sea in 1998 after ratification in Polish Parliament.

- According to International Law of Sea there are:
- Territorial sea zone (TS – 12 sea miles);
  - Adjacent zone (A – 25 sea miles);
  - Economic zone (E – 200 sea miles);
  - Open sea area (OSA, outside economic zone).

The general scheme of the sea zones was presented on Figure 17.

According to international law oceanic bed is divided into three areas of various law status:

- Bed under inner waters and territorial sea (area of shore country territory);
- Continental shelf;
- Bed under open sea (so-called International Region of Seabed – “Area”) is a joined human legacy;

Investigations, searching and extraction within the area of:

- Territorial sea are in the competence of shore country;
- Research of continental shelf can be conducted by other subjects but after receiving approval from the shore country (it is regulated by law);

International Law of Sea created International Seabed Authority – ISA which administrates and manage the open sea resources.

According to resolution of 2nd Convention the exclusive law to conduct investigations in specified and registered areas of seabed is disposed by so-called contractors [Zawadzki and Kotlinski, 2011], registered as “pioneer investors”.

The contractors can achieve extracting license from ISA for 20-25 years according to Deposit Management Plan if they fulfill conditions [Depowski et al., 1998; Mizerski and Szamalek, 2009]:

- They perform geological documentary of concretions deposit;
- They perform investigations of influence of exploitation on seabed environment;
- They will transfer part of documented deposit determined by contract (usually 50%) to ISA;
- They are technically and scientifically ready to perform extraction of concretions so the decision is connected only with economy. Currently recognizing and documentary works are conducted only by countries or groups of countries, not consortiums which decided that by current price levels they do not intend to engage into the process in upcoming years.

### ***Share of Poland***

Poland is interested in investigations of oceanic deposits from 1972. Initially it was done within international program “Intermergeo”

being realized by socialistic countries from this time.

In 1972-1975 the research geological cruises on Atlantic were organized.

In 1976-1980 the searching for and investigations of concretions Fe-Mn in Pacific area were begun. In 1985 Poland became the part of international organization Interoceanmetal (IOM) in purpose of searching, recognizing and preparing to industrial management of concretions. International agreement in this case was ratified by National Council on 1988. IOM was registered in Regional Court in Szczecin as international enterprise of legal personality. The members at that time were Bulgaria, Czechoslovakia, Cuba, DDR, Poland, Vietnam and USSR. The siege of IOM was Szczecin. After collapse of USSR the members were changed. Currently they are Bulgaria, Czech Republic, Cuba, Russia, Slovakia and Poland [Abramowski and Kotlinski, 2011; Kotlinski et al., 2004; Pienkowski, 2000; Piestrzynski, 2011].

The activity of IOM is financed by member countries in form of equal yearly contributions.

The main research of IOM were:

- 1987-1992 – investigations on area of 540 thousands of km<sup>2</sup> in Pacific in eastern part of field Clarion-Clipperton. 10 research cruises were done and area of deposit of 300 thousands of km<sup>2</sup> was divided;
- 1991 – IOM applied to Preparatory Commission for authorization of extraction allotment of surface 150 thousands of km<sup>2</sup>;
- 1992 – IOM obtained the status of “pioneer investor” from general secretary of UN.

IOM performed all of commitments occurring from the status of pioneer investor, including transferring of half of documented area to ISA. So, IOM disposes the laws to allotment of surface of 75 thousands of km<sup>2</sup>.

- Depth of concretions location – 3800-4300 m below sea level;
- Amount of concretions – 10 kg/m<sup>2</sup>.
- Metal contents – 30% Mn, Cu+Ni+Co – 2,5%.
- Resources are for 20-25 years of exploitation.
- Location of the allotments is presented on the Figure 18.

Recently (information from 7th July 2014) specialists of IOM delivered two tons of samples from Pacific seabed to Poland, from which the metals will be recovered within two years. Simultaneously, scientists will investigate the economy of concretions processing. Furthermore, the profitability

of extraction itself still requires confirmation. Director Abramowski claims that extraction of concretions could begin within the next ten years. The biggest obstacle is not completely regulated law state of oceanic seabed extraction as well issues connected with environmental protection.

Reassuring, concretions are potential source of many elements, which are currently more and

more rare to find on the land. In time when natural resources are getting low this alternative seems to be sufficiently attractive. The exploitation of concretions can start within the next 10 years.

Received December 16, 2014; reviewed; accepted February 3, 2015.

## Literatura - References

1. Abramowski T., Kotlinski R.A.: *Current challenges of exploitation of oceanic polymetallic raw materials*, AGH Journal of Mining and Geoengineering, vol. 35, iss. 4(1), p. 41–61, 2011 [in Polish].
2. Abramowski T., Szelangiewicz T.: *Exploitation of polymetallic concretions deposits from seabed*, AGH Journal of Mining and Geoengineering, vol. 35, iss. 4(1), p. 63–72, 2011 [in Polish].
3. Depowski S., Kotliński R., Rühle E., Szamalek K.: *Raw Materials of Seas and Oceans*, Wydawnictwo Naukowe Scholar, Warszawa, 1998 [in Polish].
4. Kazmin J.B. (ed.): *Iron-manganese concretions of Pacific Ocean*, Izd. Niedra, Sankt Petersburg (Leningrad), p. 66–161, 1984 [in Russian].
5. Kotlinski R., Szamalek K., Domzalski J., Mazurek A.: *Perspectives of development of exploitation of useful raw materials of seabed in aspect of Word and Polish Forecasts*, Committee of Forecasting „Polska 2000 plus”, PAN, 28 of September, Meeting of Committee „Perspectives of Sea Management – chances and threads”, 2004 [in Polish].
6. Mizerski W., Szamalek K.: *Geology and mineral raw materials of oceans*, PWN, 2009 [in Polish].
7. Morgan C.L.: *Resources Estimates of the Clarion-Clipperton Manganese Nodule Deposits (In:) Marine Mineral Deposits*, CRC. Press LLC, p. 145–170, 2000.
8. Pienkowski A.: *Cleaning the seabed*, Knowledge and Life, <http://archiwum.wiz.pl/2000/001000>, 2000 [in Polish].
9. Piestrzynski A.: *Mineral resources of oceans*, AGH Journal of Mining and Geoengineering, vol. 35, iss. 4(1), p. 303–310, 2011.
10. Sanak-Rydlewska S., Gala A.: *Methods of recovery of some metals from oceanic concretions*, AGH Journal of Mining and Geoengineering, vol. 35, iss. 4(1), p. 341–351, 2011 [in Polish].
11. von Stackelberg U., Beiersdorf H. F.: *The formation of manganese nodules between the Clarion and Clipperton fracture zones southeast of Hawaii*, Marine Geology, vol. 98, p. 411–423, 1991.
12. von Stackelberg U.: *Manganese Nodules of the Peru Basin*, in Cronan D. (ed.): *Handbook of Marine Mineral Deposits*, CRC Press, London, 2000.
13. Zawadzki D., Kotlinski R.A.: *Conditions of occurring and location of perspective iron-manganese oxide agglomerations*, AGH Journal of Mining and Geoengineering, vol. 35, iss. 4(1), p. 427–439, 2011 [in Polish].

### Konkrecje polimetaliczne – długoterminowe źródło surowców mineralnych

W czasie gdy tradycyjne źródła surowców mineralnych są w wielu miejscach na wyczerpaniu, konkrecje polimetaliczne stanowią dla nich ciekawą alternatywę. Są to zazwyczaj owalne skupiska wielu pierwiastków, głównie żelaza i manganu, które znaleźć można w głębinach oceanicznych na głębokości około 3000-5000 m p.p.m., głównie w basenie Oceanu Spokojnego. W artykule przedstawiono genezę powstania konkrecji, ich główne miejsca występowania oraz uwarunkowania dotyczące potencjalnego ich wydobywania. Przedstawiono korzyści jakie wyniknąć mogą z ich eksploatacji. Omówiono potencjalne sposoby ich wydobywania wraz z oceną stosowalności danych metod. Ponadto, przedstawiono aktualną sytuację prawną związaną z eksploatacją konkrecji wraz z jej rysem historycznym. Na tym tle oceniono możliwości Polski w kwestii wydobywania konkrecji oraz jej udział w badaniach dotyczących tego zagadnienia. Przedstawiono działkę przydzieloną Polsce w tym zakresie w basenie Clarion-Clipperton oraz badania prowadzone przez organizację InterOceanmetal.

Słowa klucze: konkrecje polimetaliczne, głębiny oceanu, surowce mineralne, rzadkie pierwiastki, wydobywanie kopalin